

FOUR^{DL}

By Chasswheel



SERVICE MANUAL

Read the manual carefully.
For more detailed information please contact us.

Chasswheel Ltd
Myllyharjuntie 6
71800 SIILINJÄRVI

Tel. +358 - 0207 559 220
Fax. +358 - 0207 559 221

CONTENTS

CONTENTS.....	2
1. TECHNICAL INFORMATION CW3 FOUR X DL.....	3
1.1 Disclosure information	4
1.2 The permanent labelling of the wheelchair	5
2. DECLARATION OF CONFIRMATION	7
3. WARRANTY	8
4. ROUTINE MAINTENANCE	9
4.1 Lubrication	10
4.2 Torque wrench settings and thread locking	10
5. PRESENTATION OF ELECTRICAL SYSTEM	11
5.2 Balance adjustment.....	12
5.3 Free-wheeling.....	12
5.4 Battery charging	12
5.5 Lightning system.....	12
5.6 Driving light lamp replacement.....	12
6. WIRING DIAGRAM	13
6.1 Main cable series	13
6.2 Axle cable series	14
6.3 Programming, engineer level.....	15
6.4 ISM-device wiring	16
6.5 The connecting of the Joystick Module.....	17
6.6 Micro switch connection.....	18
7. REMOVING AND INSTALLATION OF THE DRIVE MOTORS	20
8. CHANGING THE BALANCE ADJUSTING ACTUATOR.....	21
9. SUPPORTING RODS FIXING TO JOINT ARM.....	22
10. THE INSTALLATION OF THE RUBBER BUSHINGS.....	23
11. REMOVING AND INSTALLATION OF THE GAS SPRING (SUPPORT FRAME-SEAT FRAME).....	24
12. STEERING ADJUSTMENT	25

1. TECHNICAL INFORMATION CW3 FOUR X DL

Wheelchair classification	C
Maximum recommended mass of the user	125kg
Driving speed	10 km/h
Driving distance, depending on drive conditions	approx 35km
Clearance	100mm
Obstacle negotiation ability	100mm
Maximum obstacle negotiation ability	115mm
Slope climbing capacity	20°
Maximum safe slope	10°
Turning radius	1.15m
Turning space (with one reverse)	1.7m
Operating temperature	- 25°C - + 40°C
Charger (standard)	90256 NB Popular 8 A
Maximum permitted charging current	12 A
Weight (including batteries)	approx 130 kg
Mass of the heaviest part of the chair (Seat, leg support and batteries detached)	70kg
Seat Recaro (standard)	
-width	53,2 cm
-seat depth	46 - 51 cm
-back height	76 – 82 cm
-seat surface height at the front edge	57 cm
-seat plane angle	18° - 33°
Transport measurements (leg support and head rest detached, back rest turned into the front position)	
-width	69cm
-length	100cm
-height (varies depending on the seat)	82...89 cm
Tyres	3.00 - 8
Tyre pressure, depending on the model	1,3 - 3,5 bar (130 kPa - 350 kPa)
Light equipment	12V
-driving lights	2 x 3 W
-rear lights	24 V
-direction indicators	12 V
Electric system	24V
Main fuse	80A
Driving controller	R-Net system
Driving motors (4 x 250 W)	1000W
Brakes	4 pcs
Standard battery MK Gel Battery 73 A h	2 pcs
Spindle motor (balance adjustment)	Linak 28 S
Frame	steel, stove enamelled powder paint
Shock absorption	2 shock absorbers, I steering attenuator

1.1 Disclosure information

Annex A (normative)

Information disclosure in manufacturer's specification sheets

Manufacturer: Chasswheel Oy

Address: Myllyharjuntie 6, FIN-71800 SIILINJÄRVI

Model: CW 3 FOUR X DL

Maximum occupant mass: 125 kg

Standard reference		Min	Max	Standard reference		Min	Max
7176-5	Overall length with legrest	1270 mm	1370 mm	7176-7 1	Seat plane angle	10	21
7176-5	Overall width	692 mm	692 mm	7176-7 2	Effective seat depth	390 mm	510 mm
7176-5	folded length	1000 mm	1000 mm	7176-7 4	Effective seat width	520 mm	600 mm
7176-5	folded width	692 mm	692 mm	7176-7 5	Seat surface height at front end	570 mm	740 mm
7176-5	folded height	820 mm	820 mm	7176-7 6	backrest angle		50
	Total mass		130 kg	7176-7 7	backrest height	500 mm	600 mm
	mass of the heaviest part		80 kg	7176-7 11	footrest to seat distance	400 mm	500 mm
7176-1	static stability downhill		25	7176-7 15	leg to seat surface angle	90	160
7176-1	static stability uphill		25	7176-7 16	armrest to seat distance	150 mm	310 mm
7176-1	static stability sideways		15	7176-7 22	Front location of armrest structure	180 mm	500 mm
7176-4	energy consumption		35 km		handrim diameter		
7176-2	dynamic stability uphill		10		Horizontal location of axle		
7176-10	Obstacle climbing		115 mm	7176-5	Minimum turning radius	1150 mm	
7176-6	maximum speed forward		10 km/h				
7176-6	minimum braking distance from max speed		1000 mm				

1.2 The permanent labelling of the wheelchair

Identification plates, situated on the left side of the frame



Wheelchair classification
Maximum safe slope 10°

Obstacle negotiation ability 100mm
General driving restriction
Situated on the battery casing (rear case)

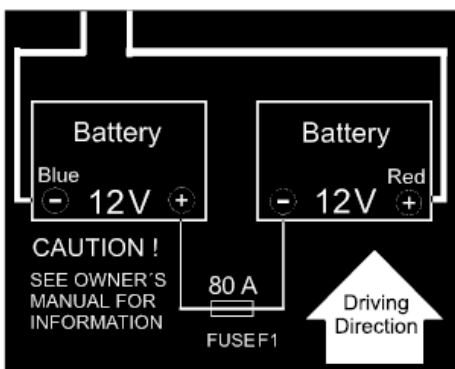

Battery connecting diagram
Situated inside the battery casing cover

80A

Main fuse value information
Situated on the main fuse box

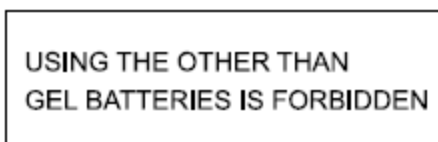

Using the other than gel batteries is forbidden - warning
Situated on the top of the battery casing (rear case)

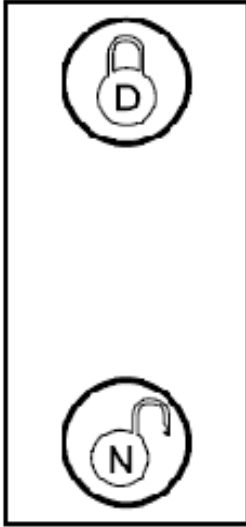

Freewheeling sign

D = breaks locked, the wheelchair can be driven

N = breaks released, the wheelchair can be towed

Situated in every fender



Attention, read the user manual

Situated on the supporting frame, both sides from the seat



Do not push the wheelchair from the back rest.

Situated on the battery casing cover



A risk of the finger trap,

These labels are situated in the points where the danger exists.



Tyre pressure range

Situated in every tyre

2. DECLARATION OF CONFIRMATION

CE

The Manufacturer:
Chasswheel Ltd
Myllyharjuntie 6
71800 SIILINJÄRVI
FINLAND

declares that the CHASSWHEEL CW3 FOUR X DL electrically powered wheelchair conforms to the following standard requirements

EN 12184: 2006
EN 1041:1998
EN ISO 14971: 2007
ISO 9999:1997
prEN 12182:1999
ISO 6440:1985
ISO 7176-1:1999
-2:2001
-3:2003
-4:1997
-5:1986
-6:2001
-7:1998
-8:1998
-9:2001
-10:1988
-11:1992
-14:1997
-15:1996

Siilinjärvi 15.3.2008

Risto Heikkinen
Managing Director

3. WARRANTY

Chasswheel Oy grants a two (2) year warranty for the CHASSWHEEL CW3 FOUR X DL electric wheelchair's frame and chassis, the driving control system, driving motors, and the seat. Batteries and charging appliances are not included in the warranty. On every wheelchair there is a model plate which shows a unique serial number.

This warranty covers faults that occur in normal operation of the wheelchair. The warranty does not cover faults caused by normal wear and improper or lack of maintenance as indicated in the owner's manual and the service instructions.

Furthermore, the warranty does not cover faults originating from overloading or incorrect programming. Normal wear occurs in parts such as tyres, rubber mountings, leaf springs, joints and slide surfaces. Increased noise of the driving motors is also caused by normal wear. Indirect expenses incurred in dealing with faults are not included in the warranty.

4. ROUTINE MAINTENANCE

The maintenance period is dependent on the use circumstances. The period should not be more than one year. However, it is necessary to observe the condition of the wheelchair all the time.

During the routine maintenance the following objects must be checked:

- the condition of tyres and their fixing
- the function of the parking brakes and the releasers
- the tightness of the screws (see page 13 for more information)
- the weariness of the joints
- the condition of the electrical cabling is checked visually
- all functions of the driving controller
- the condition of the charging socket
- the condition of the joystick rubber gaiter
- the condition of the batteries the greasing of the joints
- testing the condition of the motors (virrankulutus moottoria kohti 1 h ajan)
- tyre pressure, max. tyre pressure given on tyres label

A test drive should be done during the maintenance to observe the condition of the drive motors (veering, reduced efficiency, noise etc.)

4.1 Lubrication

Lubrication object	Interval	Lubricant
Upper joints bearing of the axle	At least once a year	lubricating oil
Slide rail of the supporting frame	in connection with assembly	graphite Vaseline and / or lubricating oil
Steering rod end rubber bushing	In connection with service of the releaser	silicon based grease or oil

4.2 Torque wrench settings and thread locking

Attachment	Moment Nm	Thread locking
The spring attachment in the frame	35	Hard
Lower bearing attachment in the axle	35	Nylock
Lower bearing attachment in the holder	35	Nylock
Holder attachment in the spring	35	Nylock
Supporting rods attachment to joint arm	50	Medium Hard
Supporting rods attachment to axles	35	Medium Hard
Steering joint bearings attachment to axles	35	Medium Hard
Attachment of drive motors	8	Medium Hard
Joint arm attachment to frame	50	Medium Hard
Attachment of the steering damper	35	Medium Hard
Attachment of the slide bracket to the slide	8	Medium Hard
Attachment of the slide bracket to the frame	12	Medium Hard
Attachment of the bearing bracket to the seat frame	12	Medium Hard
Attachment of the seat, M6	10	Medium Hard
(some seat screws may have self locking type thread) M8	35	Medium Hard

5. PRESENTATION OF ELECTRICAL SYSTEM

General description

The nominal voltage of the electric system is **24 V** for drive motors and actuator(s), the lightning system voltage is **12 V**. The power source of the system is two series connected gel batteries, which are charged by a separate charger. There are four drive motors and an actuator for balance adjustment. There are four driving motors and one actuator for the sense of gravity.

Driving controller system

The driving controller of the wheelchair is PG Drives Technology R-Net –system, which consists of the following parts:

- **Power Module**, including power electronics and programmed values.
- **Joystick Module**, including the joystick, controls and a socket for charger and programmer.
- **Actuator and lightning Module**, including connecting points for lights and actuator(s).
- **Joystick Cable**, this is a cable between the Power Module and the Joystick Module.

The connection of the driving controller

The wheelchair has four drive motors which are coupled crosswise. The right channel of the controller is coupled to the motor circuit, which consist of a parallel coupled **front right** and **rear left** drive motor. Correspondingly, the left channel of the controller is coupled to the motor circuit, which consist of parallel coupled **front left** and **rear right** drive motor. By that coupling arrangement the driving controller is made to suit the chassis structure based on the turning of the axles. The driving technique of the wheelchair differs from the driving technique of a two-wheel drive wheelchair. There are many programming possibilities in the driving controller, of which some has to be installed at the factory and the rest can be altered, when the wheelchair has to be adjusted to suit the user. Programming is made by a separate programmer (PP 1).

5.1 Drive motors

The wheelchair has four permanent magnetized 24 V motors similar to each other with gear and parking brake.

5.2 Balance adjustment

The balance adjustment is made by an actuator which moves the supporting frame in relation to the main frame. When the supporting frame is moved backwards, the seat starts to lean back at a certain stake. The actuator is controlled by the joystick, when the actuator adjusting mode is selected.

5.3 Free-wheeling

If the wheelchair must be pushed, the parking brakes are released by turning the lever in the middle of both axles about 90° counter clockwise (from ON to OFF position). A micro switch in connection with the releasing device breaks the parking brake circuit and prevents the driving of the wheelchair in brake less state.

5.4 Battery charging

The batteries are charged by a separate charger which is connected to the XLR-connector in the front of the Joystick Module. **Maximum charging current is 12 A.**

5.5 Lightning system

The wheelchair has a lightning system (12 V), which includes following:

- 2 white driving lights in front
- 2 red rear lights, LED
- 2 orange direction indicators, LED

Bulbs renewal

Driving lights:	12 V	3 W	E 10
Direction indicator:	maintenance free		
Rear lights:	maintenance free		

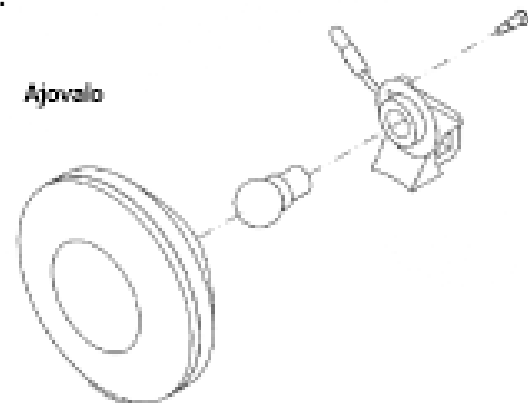

Picture 1.

5.6 Driving light lamp replacement (Picture 1)

1. The small screw behind the lamp is loosened.
2. The driving light is turned counter clockwise, when the lantern is got off from its base.
3. The lamp is removed and replaced with new lamp.
4. The reassembly is done in the opposite order.

Other lighting devices are maintenance free LED-lights.

6. WIRING DIAGRAM

6.1 Main cable series

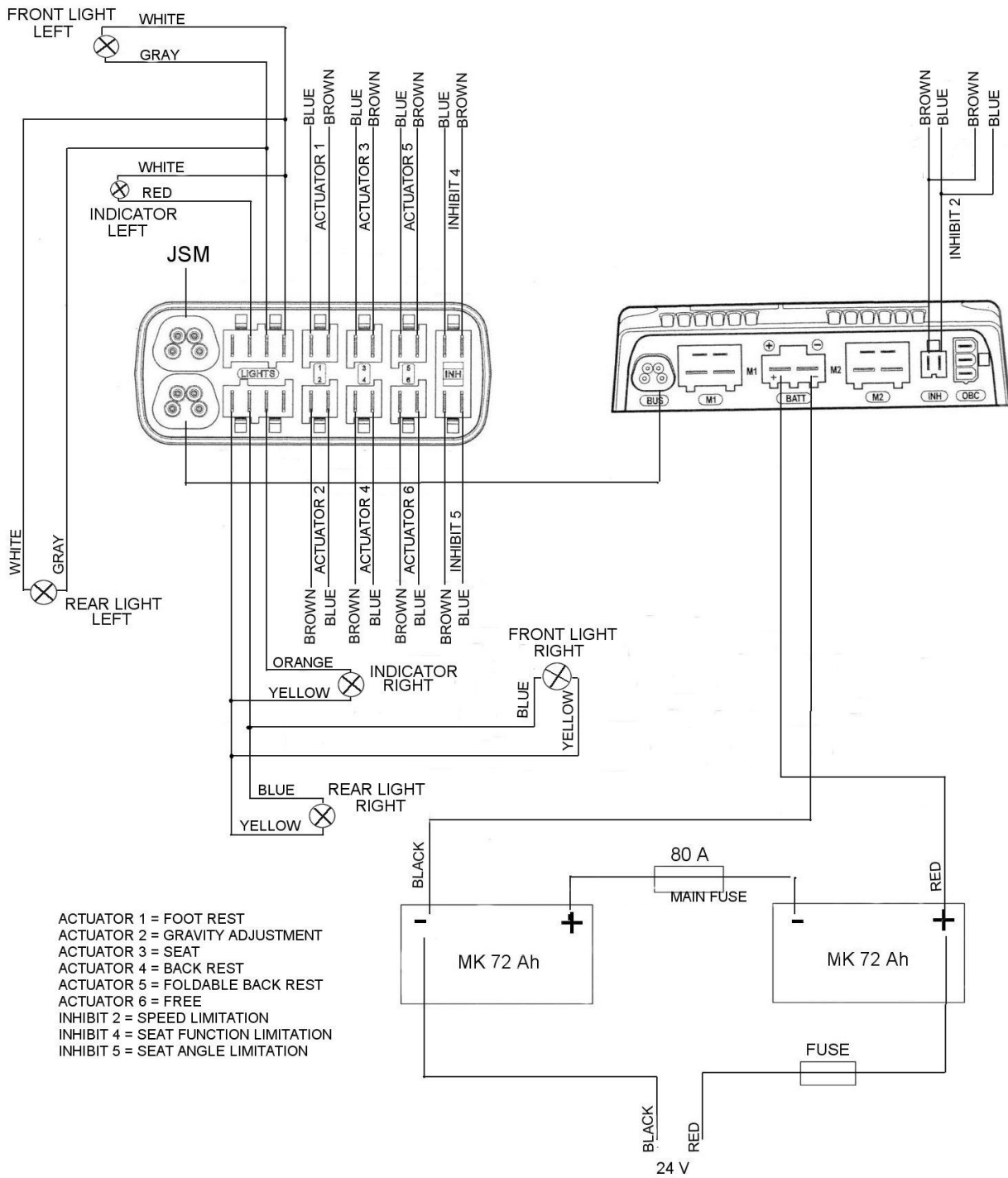

6.2 Axle cable series

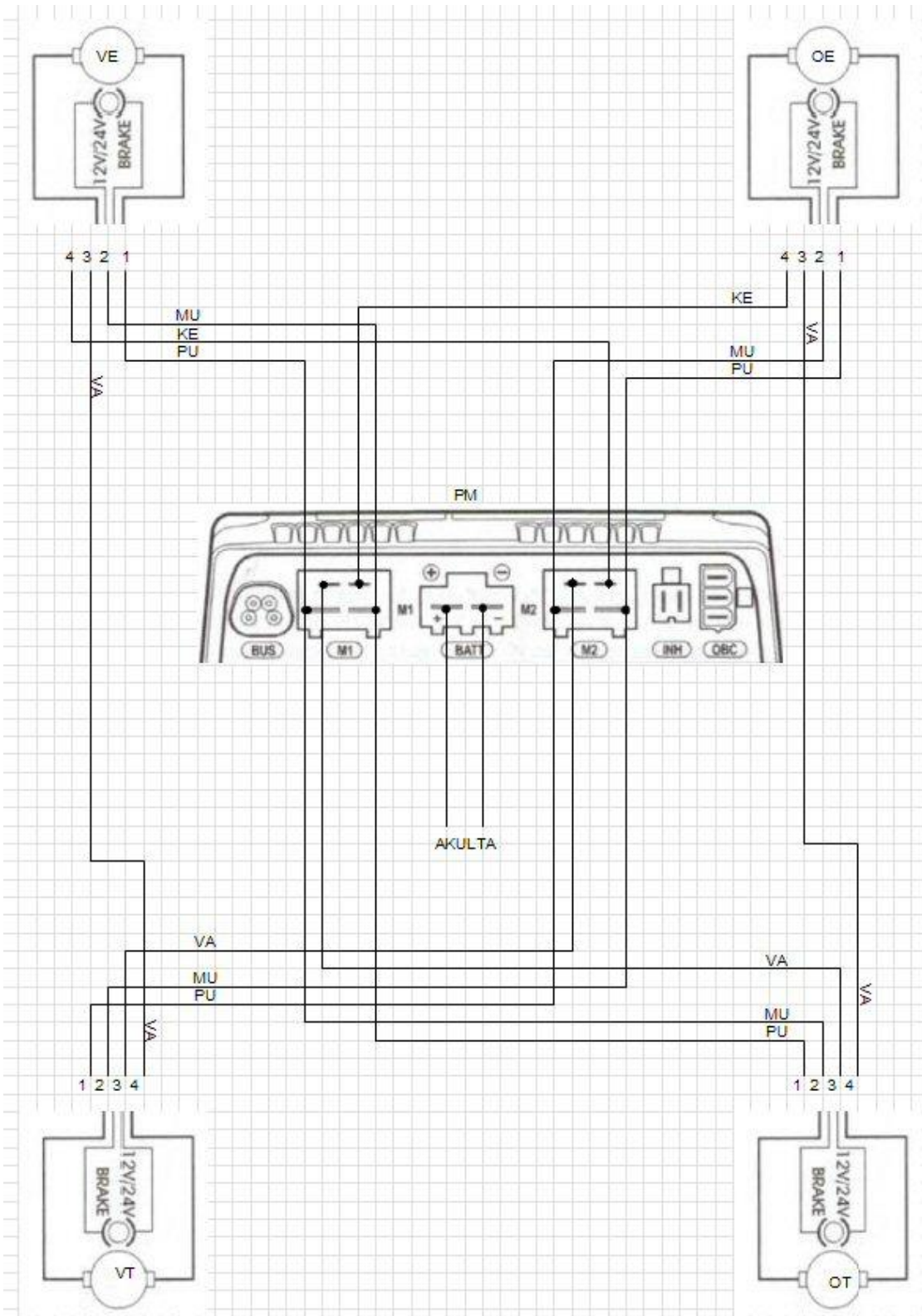

6.3 Programming, engineer level

	Profile 1	Profile 2
Profile name	Inside	Outside
Speeds		
Maximum forward speed	50%	100%
Minimum forward speed	15%	15%
Maximum reverse speed	30%	40%
Minimum reverse speed	10%	10%
Maximum turning speed	12%	12%
Minimum turning speed	10%	10%
Maximum forward acceleration	20	40
Minimum forward acceleration	10	20
Maximum forward deceleration	85	85
Minimum forward deceleration	85	85
Maximum reverse acceleration	20	40
Minimum reverse acceleration	10	20
Maximum reverse deceleration	45	45
Minimum reverse deceleration	25	25
Maximum turn acceleration	20	30
Minimum turn acceleration	10	15
Maximum turn deceleration	30	30
Minimum turn deceleration	15	15
Power	80%	100%
Torque	90%	90%
Fast brake rate	80	80

6.4 ISM-device wiring

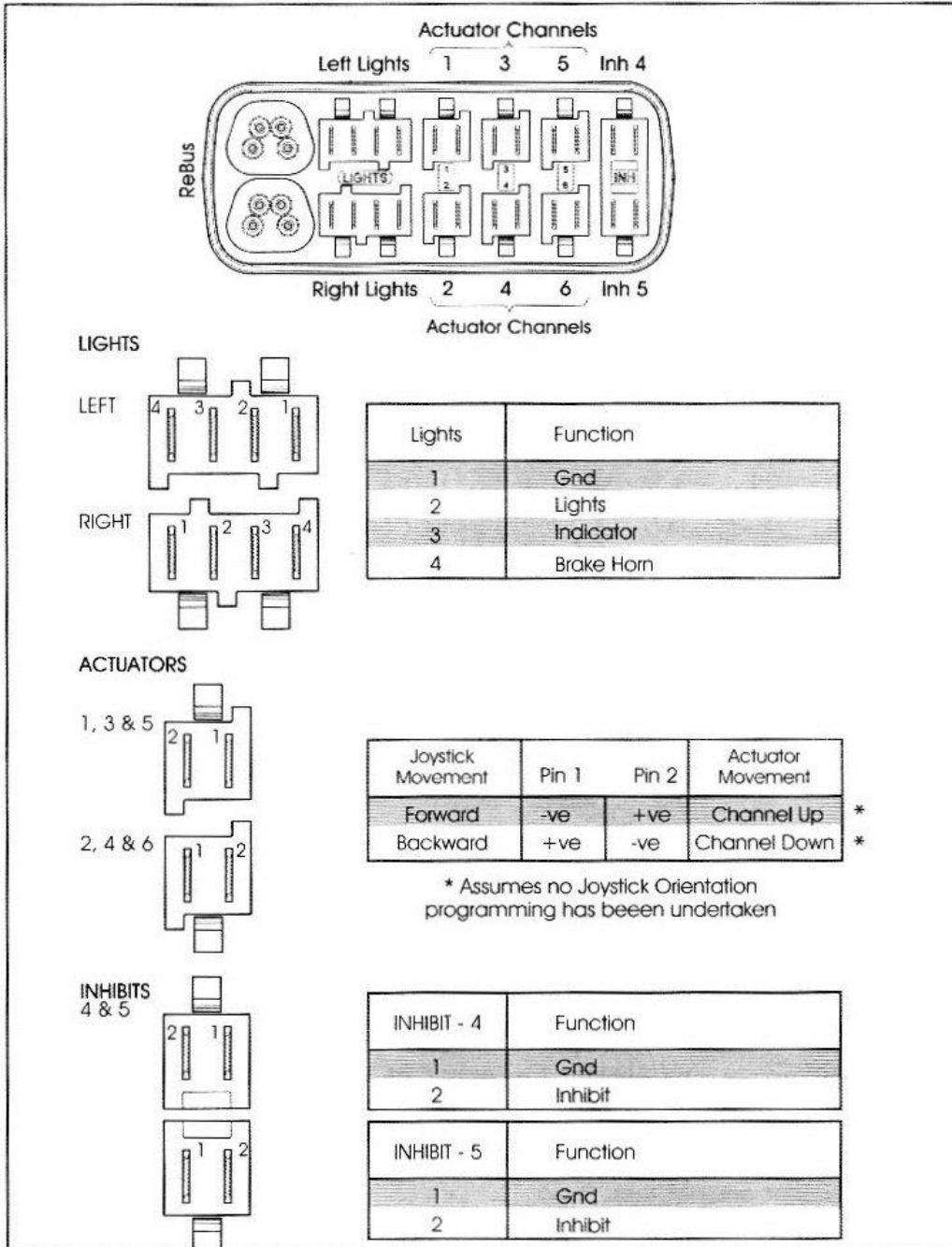

Into the ReBus-channels of the ISM-device, are connected joystick Module and Power Module through the communication cable. Cables must be situated so that they cannot be flattened and not be aimed at pull while using the wheelchair.

6.5 The connecting of the Joystick Module

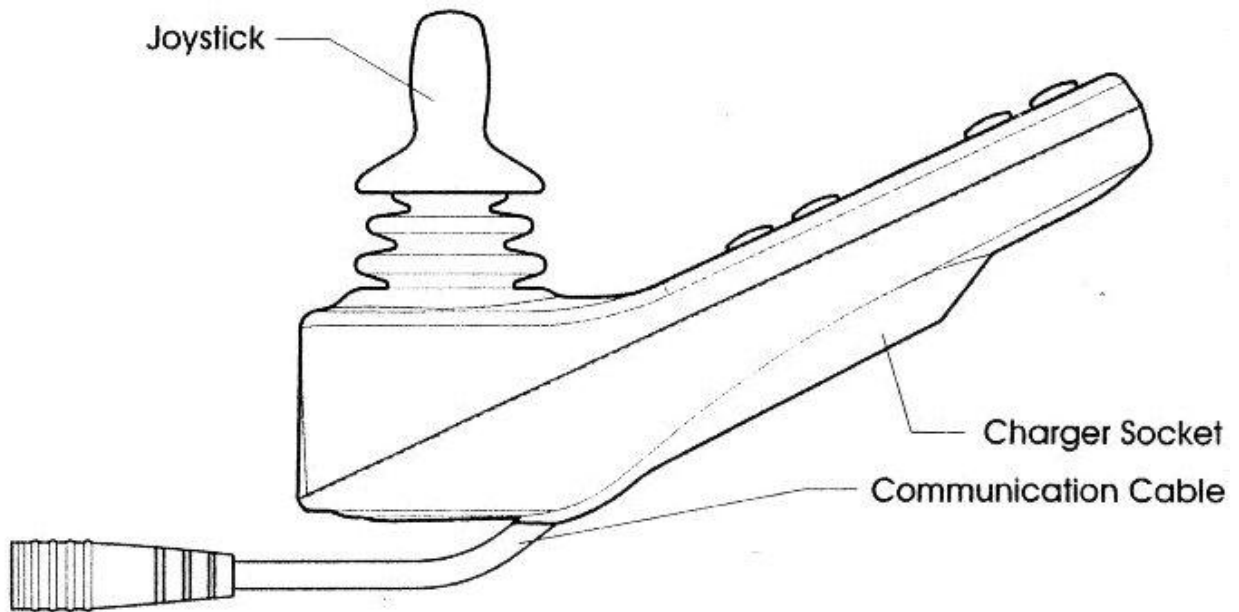

Joystick Module is connected into ISM-device through the communication cable. The cable must be situated so that it cannot be flattened and not be aimed at pull while using the wheelchair.

6.6 Micro switch connection

Inhibit 2

- located in the frame, on the right side of the control rod's guide
- limits speed in half (5km/h)
- if the cable drops off, only limited speed is in use

Connection:

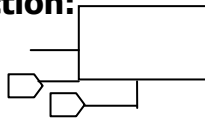

Micro switch

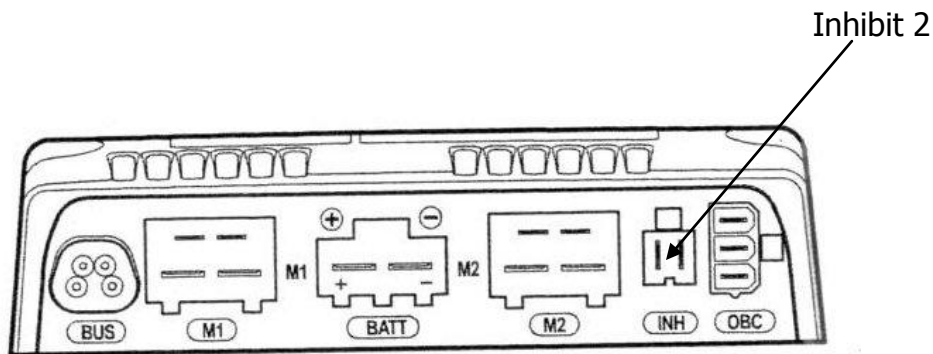

6.7 Drive motor

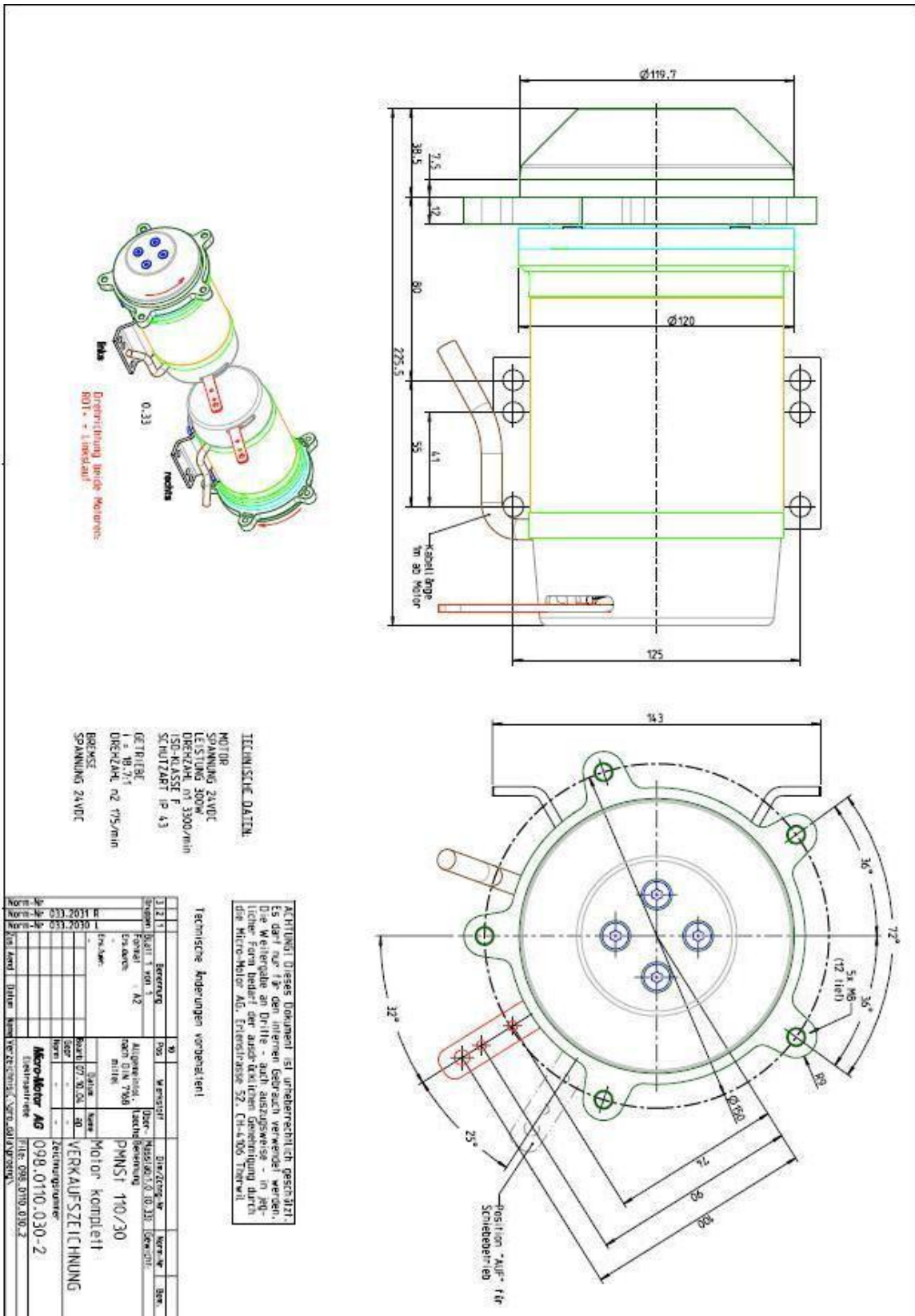

7. REMOVING AND INSTALLATION OF THE DRIVE MOTORS

Removing:

1. The battery cable is disconnected
2. The axle of the motor that is under removing is supported underside.
3. Release the tyre from the motor (5 x hexagonal bolt, 6 mm wrench)
4. Release the fender (3 x hexagonal head bolt, 10 mm wrench)
5. Release the fender holder (2 x flange bolt, 10 mm wrench)
6. Release the protective casing from the frame(4 x cross mouthed srew)
Release the seat if necessary.
7. Release the connector coming from the motor, remove the cable ties.
8. Release the remaining motor's fastening srews.
9. Motor is pulled off from the axle

Motor installation:

1. Check that the breaks are released and locked while turning the break lever.
2. Set the motor on the axle.
3. Fasten motor's underside screws, use middle hard thread locking, do not over stretch.
4. Install the fender holder and fasten the last motor connector srew
5. Connect the motor connector.
6. Install the protective caising.
7. Fasten the motor's electric cable on the supporting shaft with cable ties.
8. Install the fender.
9. Install hte tyre.
10. Remove the supporting.
11. Connect the battery and check the function.
12. After changing the motor there could appear uneven streering while driving the wheelchair.
This could be fixed by changing "STEER CORRECT"- settings. For changing the setting is needed different programming device.

8. CHANGING THE BALANCE ADJUSTING ACTUATOR

Removing of the actuator:

1. Remove the seat by opening 4 screws that holds the seat on the seat frame.
2. If the actuator is working, it is driven to middle position, when the gas spring tension is lowest.
3. One battery terminal is detached.
4. Disconnect the actuator cable from the cable series, connector 2.
5. Remove the retaining cable tie from the back tube of the seat frame.
6. Open actuators fastening screws.
7. Release the actuator from the holder

Installation of the actuator:

1. Install rear part of the actuator in to the holder and stretch the screw and the nut.
2. Screw the actuators axle so that the axle's hole and supporting frames retaining hole are concentric.
3. The axel's slot is pushed in to the mounting point and holes are aimed at concentric by using for exemple a mandrel with help.
4. Tight the front end screw and the nut.
5. Attach the actuator's cable with cable tie into the hole in the seat frame.
6. Connect the actuator's cable in the cable series, connector 2.
7. Connect the battery and check the function.
8. Connect the battery and check the function
9. Check that the cables and pipes moves properly during motion.
10. Install the seat back.

9. SUPPORTING RODS FIXING TO JOINT ARM

10.

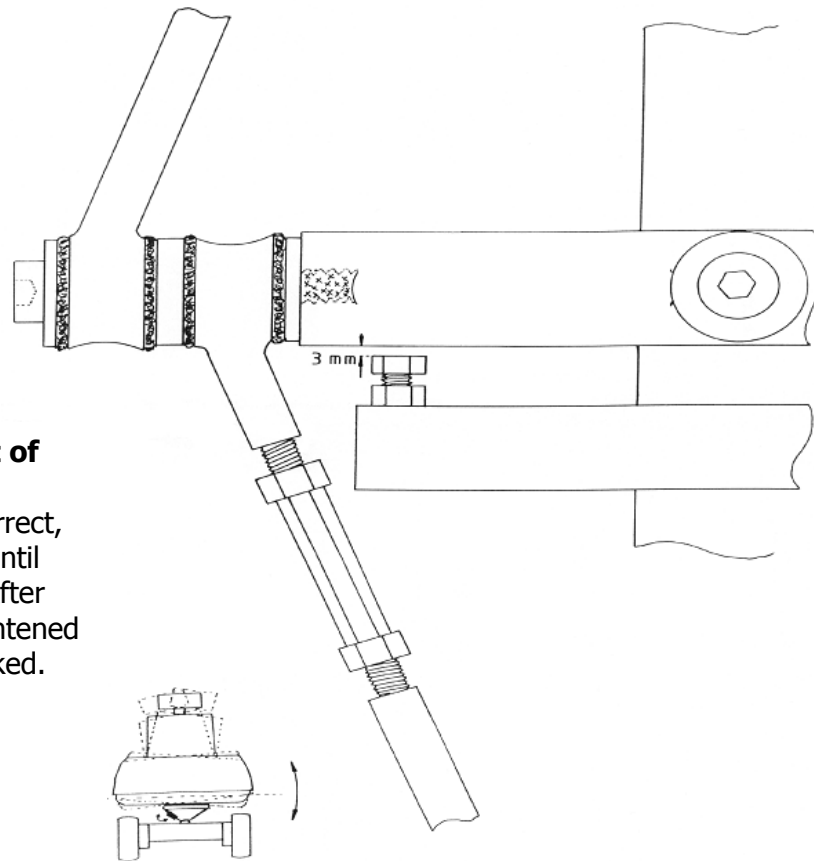

The side way adjustment of the seat frame

If the seat position is not correct, the adjusting nut is turned until the right position is found. After that the locking nuts are tightened and the bump travel is checked.

The adjustment of the bump travel

When the wheelchair is at flat plane, the clearance is adjusted with suitable gauge (3 mm).

10. THE INSTALLATION OF THE RUBBER BUSHINGS

The installation of the rubber bushing of the supporting rod

The bushings are pressed to the supporting rods by using a suitable tool. Do not use grease or oil to ease the installation. Some non-disturbing liquid, e.g. soap can be used. The joint arm thread is cleaned for thread locking liquid.

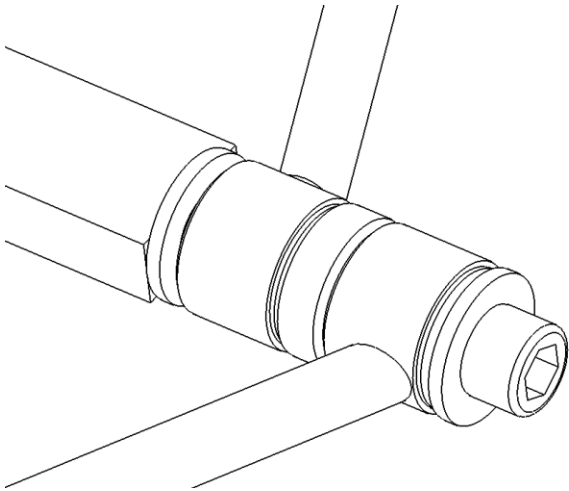

Tightening torque 60 Nm

Steering rods installation to axle tube

The rubber bushing is pressed to the end of the steering rod by using a suitable tool.

Silicon crease must be used. This lubricates the joint and eases the installation. Do not use other grease or oil. Assembly is shown in the picture below. **The upper washer is necessary to install.**

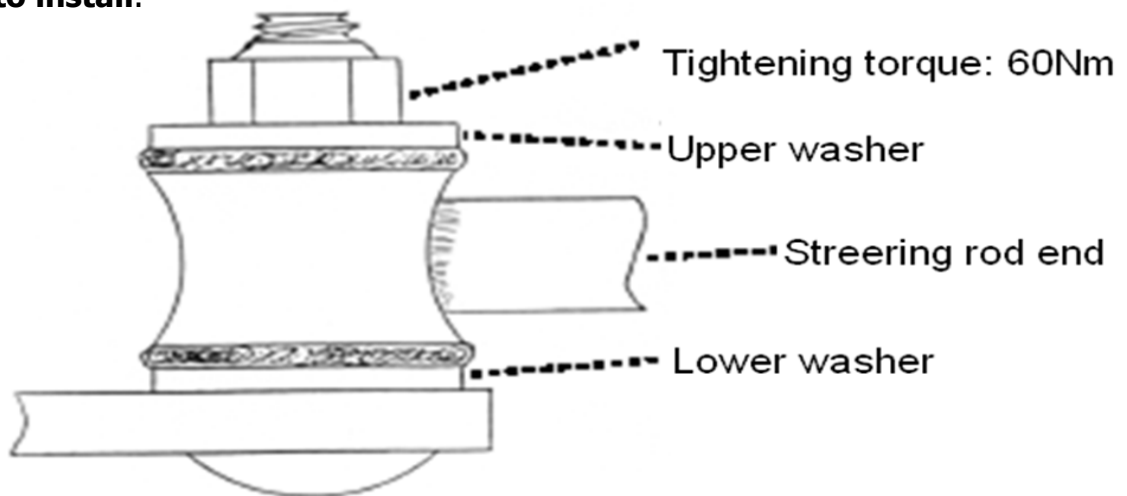

11. REMOVING AND INSTALLATION OF THE GAS SPRING (SUPPORT FRAME-SEAT FRAME)

Removing:

1. The actuator is driven to middle or front position so the gas spring has lowest tension
2. The front fixing screw of the gas spring is loosened so the tension disappears
3. The rear fixing screw is loosened.

Installation:

1. The rear end of the gas spring is fitted to seat frame. This is a joint, so the screw is not fully tightened (fig. 3)
2. The front mounting bracket is fitted to supporting frame (fig. 1)
3. The screw is fitted to the bracket with front end of the gas spring
4. The bracket is turned to horizontal position with 10 mm spanner (fig. 2)
5. The screw is tightened
6. The actuator is driven and the function is tested.

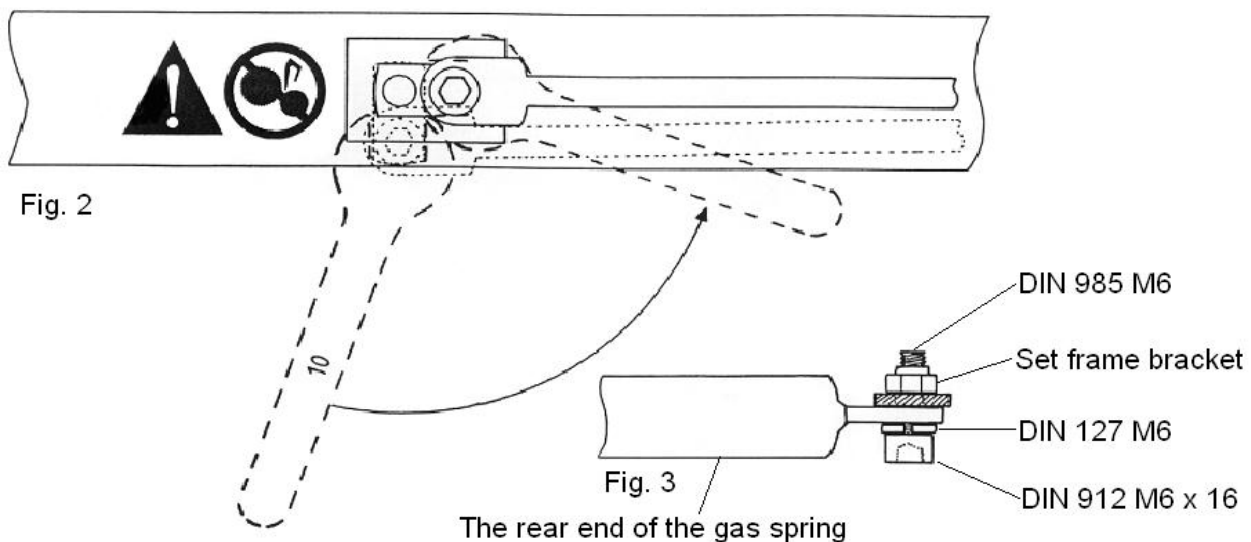
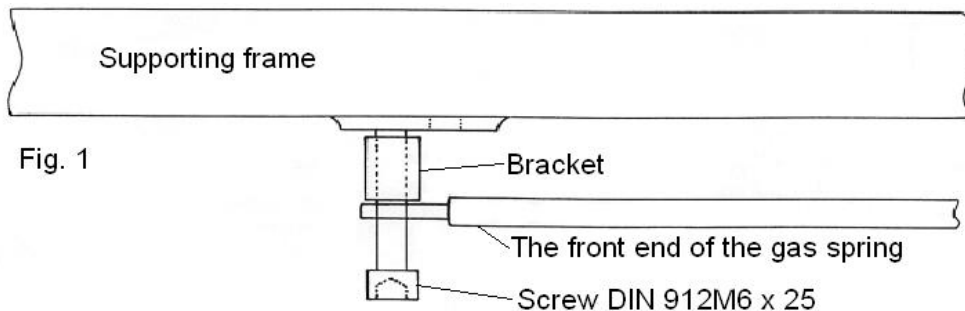

12. STEERING ADJUSTMENT

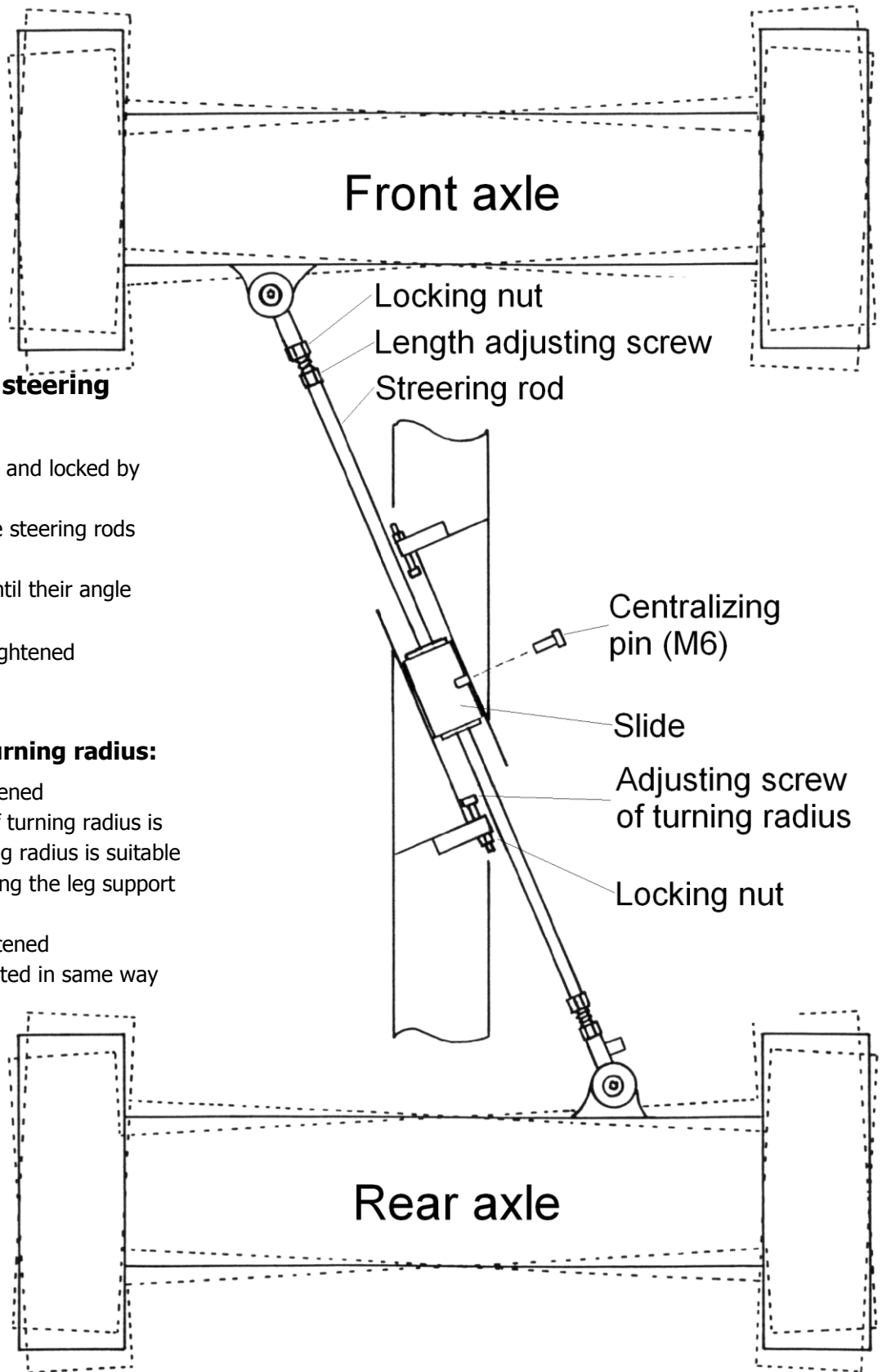

The adjustment of the steering rods:

1. The slide is centralized and locked by centralizing pin
2. The locking nuts of the steering rods are loosened
3. The rods are turned until their angle to frame is 90°
4. The locking nuts are tightened

The adjustment of the turning radius:

1. The locking nut is loosened
2. The adjusting screw of turning radius is turned, until the turning radius is suitable (the axle is not touching the leg support with turnings)
3. The locking nut is tightened
4. The other side is adjusted in same way