



Yes, you can.[®]

Invacare[®] Etude Duo[™]

Invacare[®] Etude Medley[™]

User Manual



Illustration 1

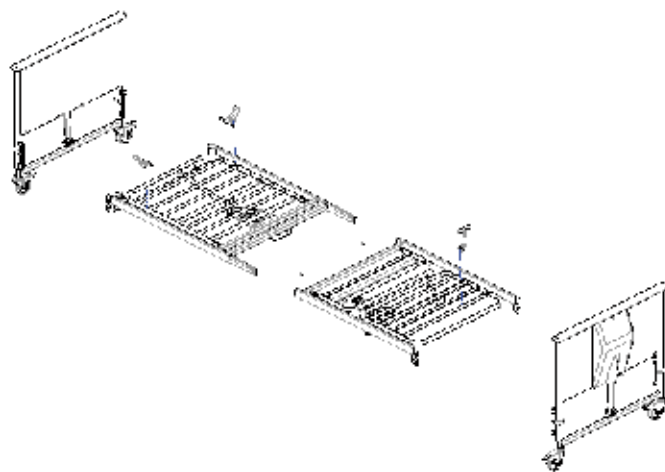

Illustration 2 a

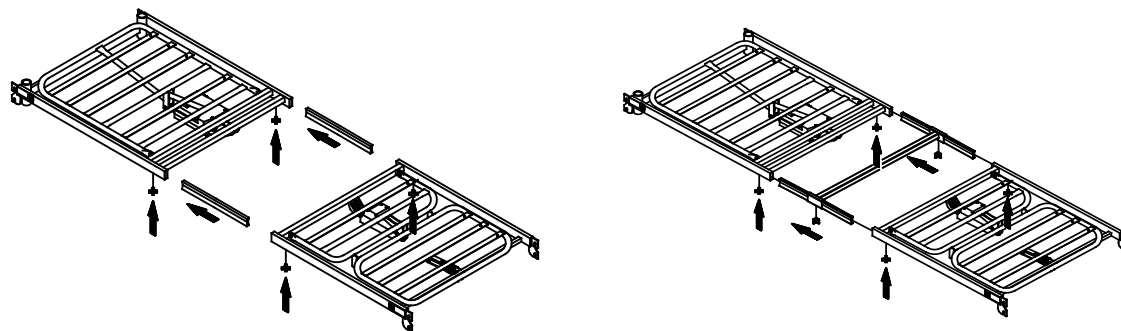

Illustration 2 b

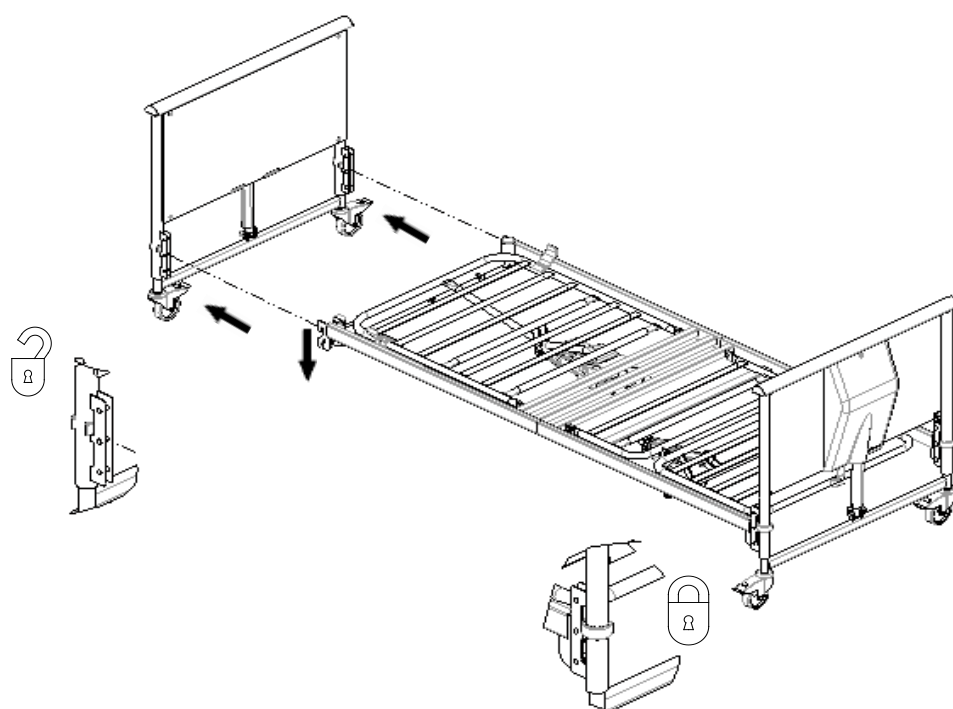

Illustration 2 c

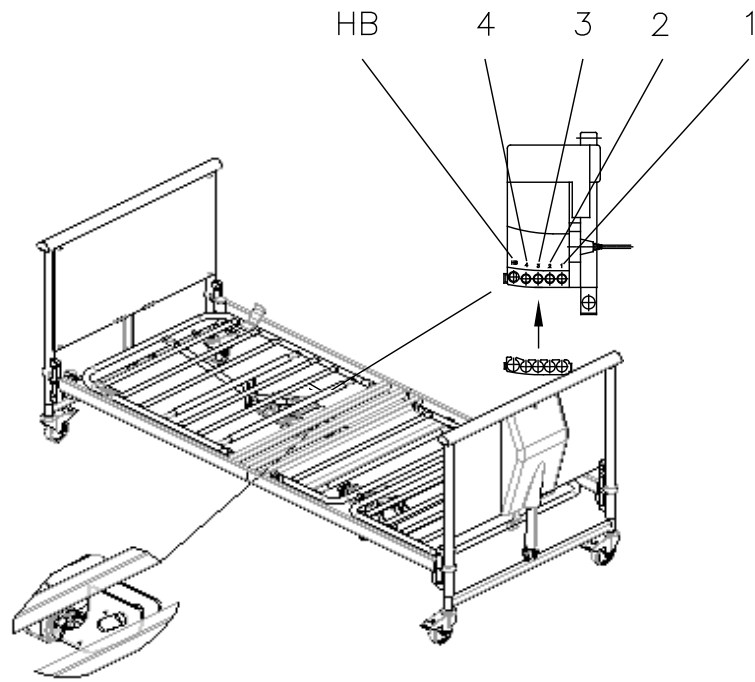
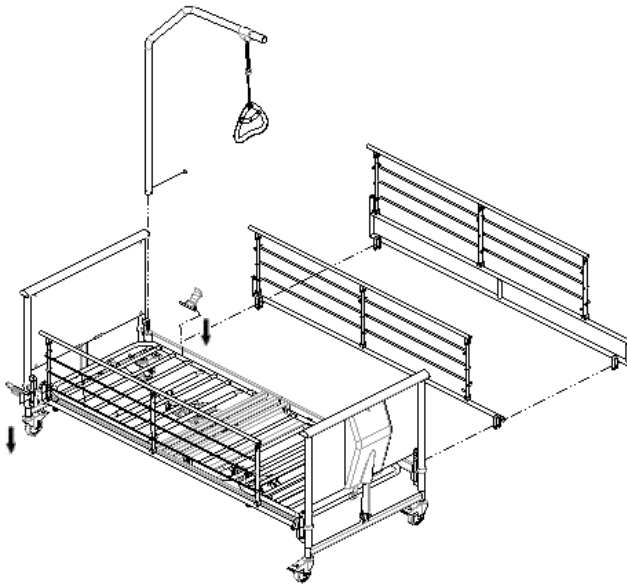

Illustration 3

Etude Duo steel



Etude Duo wood

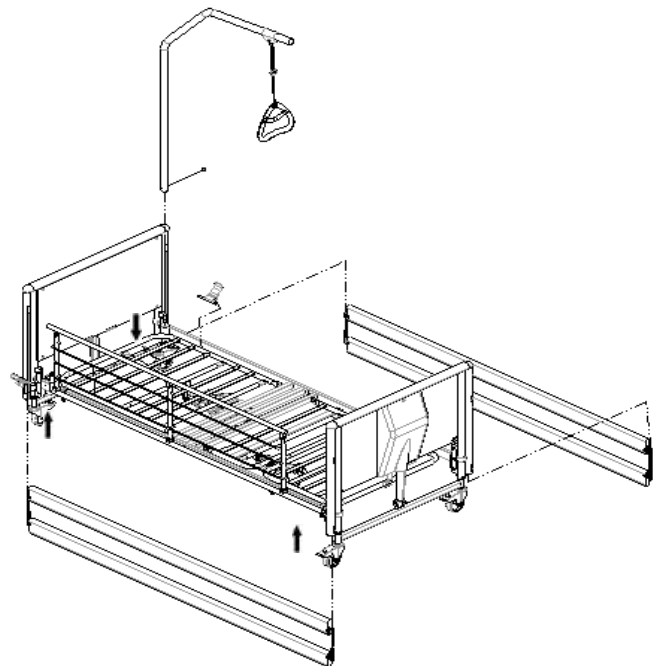

Illustration 4

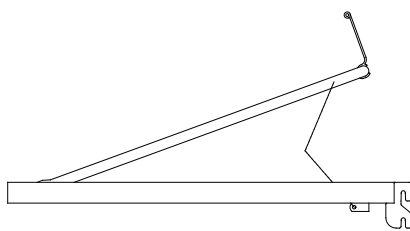

Illustration 5

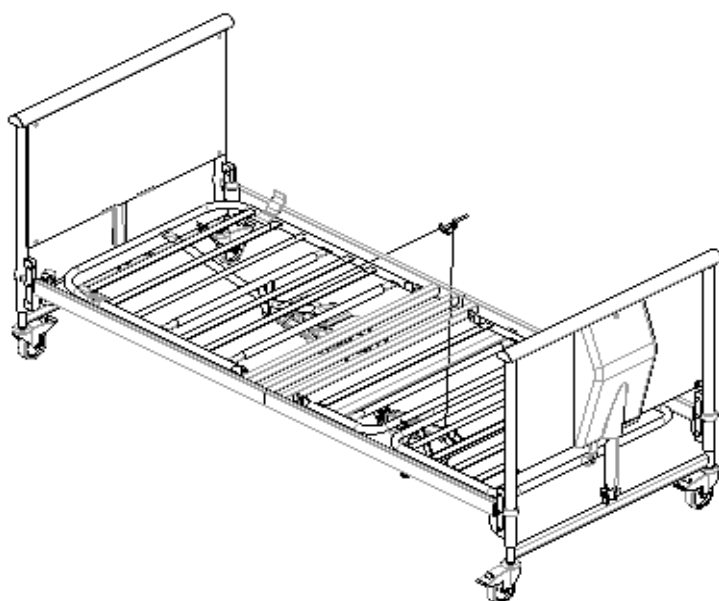

Illustration 6

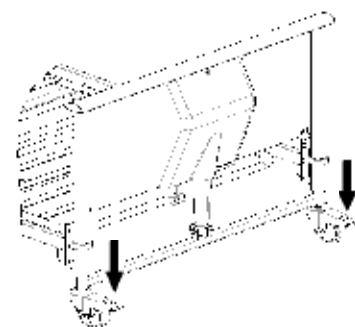

Illustration 7

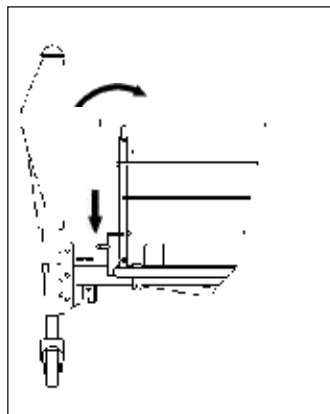
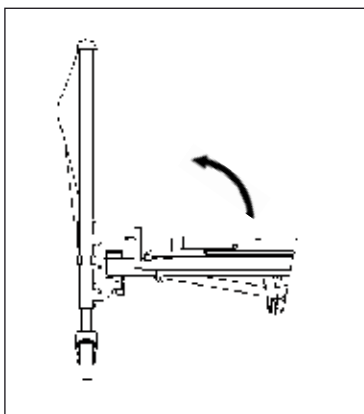
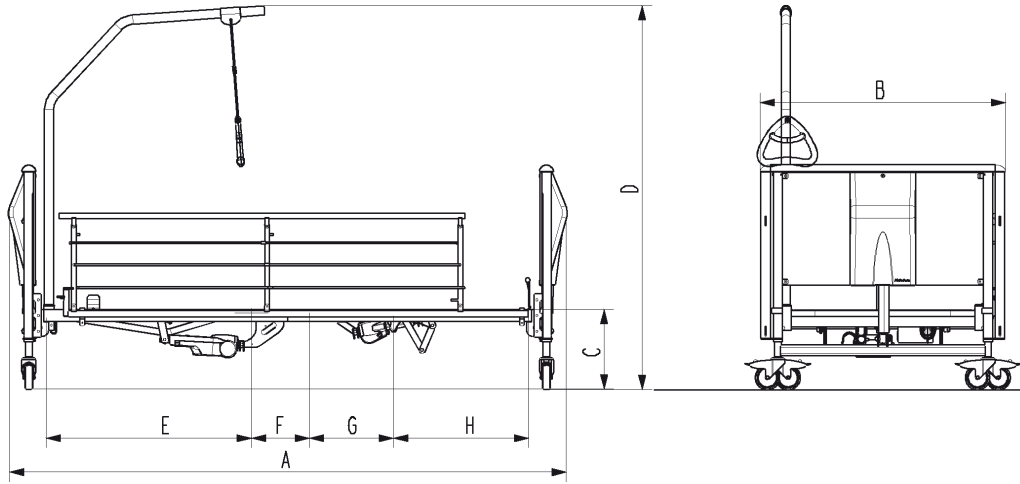
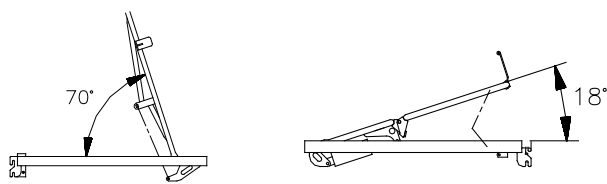

Illustration 8



Duo Steel (mm)		Duo Wood (mm)		Medley (mm)		
	Lower hinge	Upper hinge	Lower hinge	Upper hinge	Lower hinge	Upper hinge
A	2310		Not possible	2310	2215	
B	940			1020	1020	
C	330-730	400-800		400-800	330-730	400-800
D	1580-1980	1650-2050		1650-2050	1565-1965	1635-2035
E	850			850	750	
F	240			240	350	
G	350			350	340	
H	560			560	560	

Etude Duo



3- and 4-sectioned

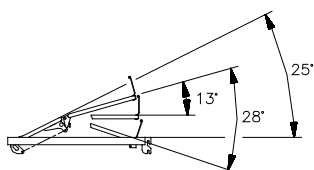

4-sectioned.
4-sectioned

Etude Medley

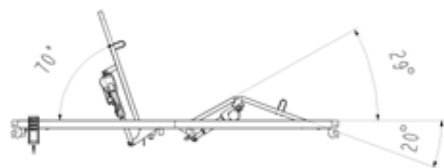

4-sectioned

Quality Declaration

Congratulations with your new bed Invacare® *Etude Duo*TM and *Etude Medley*TM from Invacare® EC-Høng A/S.

Your new bed is -marked in accordance with directive 93/42/EEC concerning medical devices.

Invacare® *Etude Duo*TM and *Etude Medley*TM is developed and constructed with consideration for the user and others handling or assisting at the bed. Furthermore, the bed is developed in accordance with the European Standard EN 1970.

Invacare® *Etude Duo*TM and *Etude Medley*TM is supervised and quality controlled throughout the entire production process, and the finished bed is inspected by our finished goods control.

Identification label and QA-mark are located on the bed confirming that the finished goods control has approved the bed.

Please read the entire user's manual before using the bed.

Invacare® EC-Høng A/S is certified according to ISO 9001 and ISO 13485.

For and on behalf of Invacare® EC-Høng A/S:



Brian Mundeling

R & D Manager

DK

KVALITETSDEKLARATION

Tillykke med Deres nye seng *Invacare® Etude Duo™* og *Medley™* fra *Invacare® EC-Høng A/S*.
Deres nye seng er CE - mærket og lever op til alle krav i henhold til direktiv 93/42/EOF om medicinske anordninger.
Sengen er udviklet og konstrueret under størst mulig hensyntagen til brugeren samt alle andre, der enten håndterer sengen eller hjælper til ved sengen.
Invacare® Etude Duo™ og *Medley™* er udviklet under hensyntagen til de sikkerhedsmæssige krav i den Europæiske Standard EN 1970. Hver seng har gennem hele produktionsforløbet været overvåget og kontrolleret, og den færdige seng er blevet inspiceret af vores færdigvarekontrol.
Typeskilt og QA-mærke påsættes sengen som dokumentation for, at færdigvare kontrollen har godkendt sengen. Før ibrugtagning af Deres seng skal De gennemlæse brugermanualen grundigt.
Invacare® EC-Høng A/S er certificeret i henhold til ISO 9001 og ISO 13485.

DE

QUALITÄTSDEKLARATION

Herzlichen Glückwunsch zu Ihrem neuen Pflegebett *Invacare® Etude Duo™* oder *Medley™* von *Invacare® EC-Høng A/S*.
Ihr neues Pflegebett ist gemäß der Richtlinie 93/42/EWG für Medizinprodukte CE-gekennzeichnet.
Das *Invacare® Etude Duo™* oder *Medley™* wurde unter Berücksichtigung der Bedürfnisse von Benutzer und Pflegepersonal entwickelt und in Übereinstimmung mit der Europäischen Norm EN 1970 konzipiert und hergestellt.
Während des gesamten Herstellungsprozesses unterliegt das *Invacare® Etude Duo™* oder *Medley™* einer ständigen Qualitätskontrolle und wird im Anschluss nochmals durch unsere Endkontrolle geprüft. Das Typenschild und QA-Kennzeichen sind am Bett angebracht, um die Abnahme durch unsere Qualitätskontrolle zu bestätigen.
Bitte lesen die gesamte Bedienungsanleitung, bevor Sie das Bett in Gebrauch nehmen.
Invacare® EC-Høng A/S ist zertifiziert nach ISO 9001 und ISO 13485.

NL

KWALITEITSGARANTIE

Gefeliciteerd met de aanschaf van uw nieuwe bed *Etude Duo™* ann *Medley™* van *Invacare® EC-Høng A/S*.
Invacare® Etude Duo™ ann *Medley™* is CE - gecertificeerd en goedgekeurd conform richtlijn 93/42/EEC betreffende medische hulpmiddelen.
Invacare® Etude Duo™ ann *Medley™* is ontwikkeld en geconstrueerd met inachtneming van de behoeften van de gebruiker en verzorgers.
Invacare® Etude Duo™ ann *Medley™* is ontwikkeld in overeenstemming met de Europese Standaard EN 1970.
Gedurende het gehele productieproces is het *Etude Duo™* ann *Medley™* bed gecontroleerd op kwaliteitsaspecten en het complete bed is na productie zorgvuldig gecontroleerd. Het productlabel en de QA-markering zijn op het bed bevestigd om aan te tonen dat de bedden zijn gecontroleerd en goed zijn bevonden door de afdeling productcontrole. Wij verzoeken u vriendelijk de gehele gebruikershandleiding te lezen voordat u het bed in gebruik neemt.
Invacare® EC-Høng A/S is ISO 9001 en ISO 13485 gecertificeerd.

IT

DICHIARAZIONE DI QUALITÀ

Complimenti per aver scelto il letto *Invacare® Etude Duo™* e *Medley™* prodotto da *Invacare® EC-Høng A/S*.
Il vostro nuovo letto è marcato CE - ai sensi della Direttiva 93/42/EEC relativa ai dispositivi medici.
Il letto è stato progettato e costruito con un occhio di riguardo per gli utilizzatori e per i loro assistenti. *Invacare® Etude Duo™* e *Medley™* è stato realizzato nel rispetto della Normativa Europea EN 1970.
Il letto è stato oggetto di accurate verifiche qualitative durante l'intero processo produttivo; una volta completato è stato controllato dal nostro servizio prodotti finiti.
Un'apposita targhetta e la marcatura QA sono state apposte sul letto a conferma dell'avvenuta verifica e accettazione del prodotto da parte del servizio qualità. Prima di utilizzare il letto vi invitiamo a leggere integralmente il manuale d'uso.
Invacare® EC-Høng A/S è un'azienda certificata ai sensi della Normativa ISO 9001 e ISO 13485.

ES

DECLARACIÓN DE CALIDAD

Enhorabuena por su nueva cama *Invacare® Etude Duo™* y *Medley™* de *Invacare® EC-Høng A/S*.
Su nueva cama cuenta con el marcaje CE - de acuerdo a la directiva 93/42/EEC que hace referencia a los aparatos médicos.
Invacare® Etude Duo™ y *Medley™* ha sido diseñada y fabricada teniendo en cuenta a los usuarios y las personas que los asisten.
La cama *Invacare® Etude Duo™* y *Medley™* ha sido diseñada de acuerdo a la normativa Europea EN 1970.
El proceso de producción del modelo *Invacare® Etude Duo™* y *Medley™* ha sido supervisado en su totalidad y su calidad inspeccionada, por nuestro control de producto acabado.
La cama cuenta con una placa y marca CE que confirma que la misma ha sido inspeccionada por el control de producto acabado. Por favor lea el manual antes de utilizar la cama.
Invacare EC-Høng A/S es una empresa certificada ISO 9001 e ISO 13485

FR

DÉCLARATION DE QUALITÉ

Félicitations! Vous avez choisi votre nouveau lit *Invacare® Etude Duo™* et *Medley™* de *Invacare® EC-Høng A/S*.
Votre nouveau lit est marqué CE conformément à la directive 93/42/EEC concernant les dispositifs médicaux.
Invacare® Etude Duo™ et *Medley™* a été développé et construit en considérant systématiquement les besoins de l'utilisateur et des tierces personnes lors de la manipulation du lit ou de son utilisation. *Invacare® Etude Duo™* et *Medley™* a été développé conformément au Standard Européen NF EN 1970 et NF EN 60601-2-38.
Invacare® Etude Duo™ et *Medley™* a été supervisé et contrôlé tout au long du processus de fabrication et le lit achevé a été inspecté par le contrôle des produits finis. La plaque d'identification et la marque QA sont placées sur le lit attestant que le contrôle des produits finis a approuvé le lit. Le lit répond aux exigences de l'analyse de risques de la norme NF EN 14971. Nous vous remercions de lire le Manuel de l'Utilisateur dans son intégralité avant d'utiliser le lit.
Invacare® EC-Høng A/S est certifiée ISO 9001 et ISO 13485.

PT

DECLARAÇÃO DE QUALIDADE

Parabéns pela sua nova cama *Invacare® Etude Duo™* e *Medley™* da *Invacare® EC-Høng A/S*.
A cama tem a marca CE - em conformidade com a directiva 93/42/EEC referente a aparelhos médicos.
A cama foi concebida e desenhada, tendo em consideração o seu utilizador e o seu(s) assistente(s), que o ajudarão a manipular a cama. A cama foi concebida em conformidade com o Standard Europeu EN 1970.
Durante todo o processo de fabrico e produção, a cama *Invacare® Etude Duo™* e *Medley™* foi supervisionada e a sua qualidade controlada, sendo o produto final inspeccionado e testado pelo nosso controlo de qualidade. As etiquetas e a marca QA, são colocadas na cama, após a aprovação final da cama, confirmando e garantindo a conformidade com o nosso controlo de qualidade. Por Favor, leia atentamente este manual de utilizador antes de utilizar a sua cama.
A *Invacare® EC-Høng A/S* está certificada em conformidade com ISO 9001 e ISO 13485.

PL

DEKLARACJA ZGODNOŚCI

Dziękujemy za obdarzenie nas zaufaniem i wybór naszego nowego produktu *Etude Duo™* lub *Etude Medley™* firmy *Invacare® EC-Høng A/S*.
Łóżko pielęgnacyjne zostało zaklasyfikowane do grupy wyrobów medycznych i opatrzone znakiem CE zgodnie z dyrektywą 93/42/EWG.
Model *Etude Duo™* i *Etude Medley™* zostały zaprojektowane przy uwzględnieniu indywidualnych potrzeb pacjentów i personelu medycznego oraz wyprodukowane zgodnie z wymaganiami europejskiej normy EN 1970.
Produkty firm *Invacare®* są poddawane częstym kontrolom z zakresu jakości podczas wszystkich etapów procesu produkcyjnego, a po zakończeniu procesu produkcyjnego kontroli końcowej.
Na produkcie została umieszczona tabliczka znamionowa oraz oznaczenie QA potwierdzające, że produkt został poddany wymaganym kontrolom jakości.
Przed rozpoczęciem użytkowania produktu należy zapoznać się z treścią niniejszej instrukcji obsługi.
Produkty firmy *Invacare® EC-Høng A/S* posiadają certyfikat jakości zgodnie z normami ISO 9001 oraz ISO 13485.

Table of contents

1.	General	6
2.	Unpacking your product	9
	2a. <i>Etude Duo</i>	9
	2b. <i>Etude Medley</i>	10
3.	Assembly of <i>Etude Duo</i> and <i>Etude Medley</i>	11
4.	Fitting the accessories	14
5.	Conversion from 3 to 4 sectioned mattress support (only <i>Etude Duo</i>)	18
6.	Operating the bed	19
	6a. Operating beds with 3-sectioned mattress support	19
	6b. Operating beds with 4-sectioned mattress support	20
	6c. Adjustment of the leg section	21
	6d. Operation of brakes	21
	6e. Tilt function	21
7.	Emergency lowering of the backrest and/or thigh section	22
8.	Operating the accessories	23
	8a. Accessories <i>Etude Duo</i>	23
	8b. Accessories <i>Etude Medley</i>	23
9.	Dismantling the <i>Etude</i> bed	25
10.	Order numbers	26
	10a. Order numbers <i>Etude Duo</i>	26
	10b. Order numbers <i>Etude Medley</i>	27
11.	Cleaning and disinfection	28
12.	Maintenance and servicing	28
13.	Maintenance chart	29
14.	Disposal	30
15.	Trouble-shooting the electrical system	31
16.	Replacement of control unit and cables	32
17.	Technical specifications	34
18.	Weights	35
	18a. Weights <i>Etude Duo</i>	35
	18b. Weights <i>Etude Medley</i>	35

Congratulations

You have chosen an *Invacare*® **Etude Duo** or **Etude Medley** nursing bed. **Etude Duo** and **Etude Medley** are home nursing beds manufactured by *Invacare*® EC-Høng that are designed to be dismantled.

Invacare® EC-Høng is certified according to DS/EN ISO 9001 and ISO 13485 which ensures that our customers are always supplied with products of uniform quality.

Throughout the entire production process our materials/products are quality controlled by the operators. Additionally, a final test is carried out prior to packaging and shipping.

QA XXX

The operator carrying out the final test, which includes a check of all moveable parts, motors and castors, issues a QA number on the product thereby confirming its quality. To identify the product please look at the Product-label.



If the product does not correspond to the quality demands of *Invacare*® EC-Høng, it will be discarded.

If, contrary to our expectations, a problem should arise in connection with the delivered product, please contact your *Invacare*® supplier. An address list is shown on the back side on this manual. *Invacare*® reserves the right to alter product specifications without prior notice.



Invacare® accepts no liability for any use, change or assembly of the product other than as stated in this user's manual.
Accessories not mentioned in this manual must not be used.

I. General

- The **Etude** nursing bed has been developed for domestic care and features a comfortable sitting and lying position for the patient. Furthermore, ergonomical operation for the carer is ensured.
The bed is not intended for hospital use.
- The **Etude** bed is marked with the CE - mark in accordance with directive 93/42/EEC concerning Medical Apparatus.
- The **Etude** bed has been tested and approved according to EN 1970:2000 and EN 60601-2-38 + A1:2000. (EN 60601-2-38 + A1:2000 only according to the domestic care regulations).
- The motors and control of the **Etude** bed have been approved according to EN 60601:1996-03.
- The **Etude** bed has been approved and marked with the TÜV mark.
- The **Etude** bed has undergone a risk analysis according to EN ISO 14971:2001-03.
- The control unit, external power supply and motors are protected according to IP 54.
- The hand control unit is protected according to IP 66.
- Max. weight: 180 kg
- Max. patient weight: 145 kg (provided that the weight of the mattress and the accessories do not exceed 35 kg).
Important! The max. load of the bed must not be exceeded.
- If the patient height exceeds 2 meters it is recommended to use a mattress support extension.
- The cabling consists of flexible cables with plugs at both ends, to ease replacement.
- The bed is not intended for children under 12 years and psychiatric patients.
- Remove the plug from the mains voltage before moving the bed. The cable must be kept clear off the floor and the castors during transportation.
- The adjustment area of the mattress support is: 40-80 cm or alternatively 33-73 cm. For wood version of **Etude Duo** only 40-80 cm.
- The angle between the lower leg section and horizontal is adjustable from 0° to 15°.





It can be dangerous to roll over the mains cable.
Do not bring mains cable into moving parts.



Disconnect the plug from the mains before moving the bed.
The cables must be mounted in such a way that they are kept clear of the floor and do not block the castors.

We recommend to mount the mains cable on the hook for this purpose, see picture below.



Environment Conditions		
Temperature	Relative humidity	Atmospheric pressure
Storage		
From - 10° C	20%	700 hPa
To + 50° C	75%	1060 hPa
Operating		
From + 5° C	20%	700 hPa
To + 40° C	75%	1060 hPa
Be aware that when a bed has been stored under low temperatures, it must adjusted to operating conditions before use.		



The bed's castors must be locked during nursing of a patient in bed or when using any positioning function.



Adjust the mattress support sections to horizontal position and lower the bed to its lowest position before moving the bed.
Hold the top of the bed end with both hands while the bed is pushed/pulled.
Any floor obstacle must not be higher than 10 mm.

If the functions of the bed change, check the bed according to the maintenance chart, chapter 13.



All service and maintenance work described in chapter 13 must only be performed by personnel who have been instructed and trained by *Invacare*®.



The **Etude** bed fulfils all requirements regarding maximum distances.
However, if the bed is used for the care of patients with a small body dimensions, it must be especially noted that there is a risk of such a patient slipping through the openings between the side rails or through the opening between the side rail and the mattress support.



The bed must not be used by patients under 12 years of age, or by patients with body size equivalent to an average 12-year-old or smaller.



Always lower the bed to the lowest position before leaving the patient in the bed unattended.



Electromagnetic interference between the bed and other electrical products can occur. To reduce or eliminate such electromagnetic interference, increase the distance between the bed and the products or switch them off.

This medical bed can be used together with medical electrical equipment connected to the heart (intracardially) or the blood vessels (intravascularly), provided that following points are respected:

- The medical bed should be equipped with means for potential equalization connection marked out by a symbol shown in the back of this manual.
- Medical electrical equipment should not be fixed on the bed's metallic accessories such as side rails, lifting pole, drip rod, bed ends ect.

In addition, the medical electrical equipment power supply cord should be kept clear of the accessories or any other moving part of the bed.



There is a risk of entrapment between the backrest and the cross rail on the head end of the mattress support. There is also a risk of getting squeezed between the leg section and the cross rail on the foot end of the mattress support when the backrest/leg section is lowered.

2. Unpacking your product

2a. Etude Duo

- Delivery:
1. Corrugated cardboard boxes
 2. Transport adaptor

For a complete bed the following parts must be provided:

Etude Duo

A) Mattress support

3-sectioned = ETUDE.DE300.M0 (standard European plug/voltage, whitout tilt)
or

4-sectioned = ETUDE.FE300.M0 (standard European plug/voltage, whitout tilt)

Mattress support includes 2 mattress handles, hand control and motors mounted on the mattress support

B) 1 pair of bed ends = ETUDE.000HI.MI with motor cover or ETUDE.000JI.MI without motor cover

C) Steel version with steel side rail: 1432784-0152

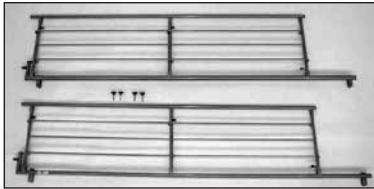

Wood version with wooden side rail and with mounting kit: 1441497-0101

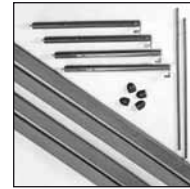

D) Lifting pole = 50.57600.M0

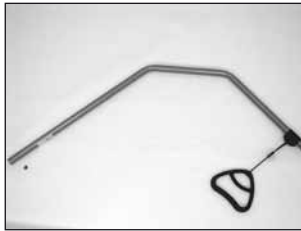

Order numbers:

ETUDE/3.EU.66.MI
ETUDE/4.EU.66.MI

Etude Duo 3-sectioned steel **with** motor cover on transport adaptor
Etude Duo 4-sectioned steel **with** motor cover on transport adaptor

ETUDE/3.EU.67.MI
ETUDE/4.EU.67.MI

Etude Duo 3-sectioned wood **with** motor cover on transport adaptor
Etude Duo 4-sectioned wood **with** motor cover on transport adaptor

ETUDE/3.EU.68.MI
ETUDE/4.EU.68.MI

Etude Duo 3-sectioned steel **without** motor cover on transport adaptor
Etude Duo 4-sectioned steel **without** motor cover on transport adaptor

ETUDE/3.EU.69.MI
ETUDE/4.EU.69.MI

Etude Duo 3-sectioned wood **without** motor cover on transport adaptor
Etude Duo 4-sectioned wood **without** motor cover on transport adaptor

ETUDE/3.EU.70.MI
ETUDE/4.EU.70.MI

Etude Duo 3-sectioned steel **with** motor cover in box
Etude Duo 4-sectioned steel **with** motor cover in box

ETUDE/3.EU.71.MI
ETUDE/4.EU.71.MI

Etude Duo 3-sectioned wood **with** motor cover in box
Etude Duo 4-sectioned wood **with** motor cover in box

ETUDE/3.EU.72.MI
ETUDE/4.EU.72.MI

Etude Duo 3-sectioned steel **without** motor cover in box
Etude Duo 4-sectioned steel **without** motor cover in box

ETUDE/3.EU.73.MI
ETUDE/4.EU.73.MI

Etude Duo 3-sectioned wood **without** motor cover in box
Etude Duo 4-sectioned wood **without** motor cover in box

Bed end Duo and side rails will always be delivered in pairs.

Standard silver is colour code **.MI** for the bed end and **.M0** for the mattress support.

2.

1.



2b. Etude Medley

- Delivery: 1. Corrugated cardboard boxes
2. Transport adaptor



For a complete bed the following parts must be provided:

Etude Medley

- A) 4-sectioned mattress support = ETUDE.ME300.M0
mattress support includes 2 mattress handles, hand control and motors mounted on the mattress support.



- B) 1 pair of bed ends = ETUDE.000MI.MI



- C) Steel version with steel side rail:
1491226-0152



- Wood version with wooden side rail:
1491224-0101



- D) Lifting pole 50.57600.M0

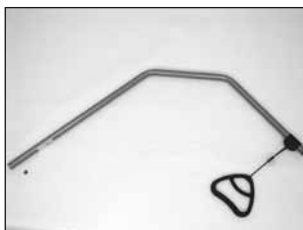

Order numbers:

Mattress support:

ETUDE.ME300.M0

Etude Medley 4-sectioned mattress supports

Bed ends:

ETUDE.000MI.MI

Etude Medley bedends (1 pair)

Side rails:

1491224-0101

Etude Medley wooden side rail (1 pair)

1491226-0152

Etude Medley steel side rail (1 pair)

Lifting pole:

50.57600.M0

Lifting pole

Standard silver is colour code **.MI** for the bed end and **.M0** for the mattress support.

3. Assembly of *Etude Duo* and *Etude Medley*

(see illustration 1, 2a, 2b and 2c in in front of the users manual)

a) Mattress support

- Place the two inserts in the head end of the mattress support. The inserts must be mounted in such a way that one extends further out of the side tube than the other.
- Loosely screw in the two finger screws.
- Push the foot end of the mattress support onto the two inserts.
- Tighten the two finger screws.
- Retighten the two finger screws at the head end of the top frame.
- Attach the two mattress support handles to the mattress support (only *Etude Medley*).
- Turn the two mattress handles of the backrest up (only *Etude Duo*).
- Turn the handle of the leg section up (only *Etude Duo*).

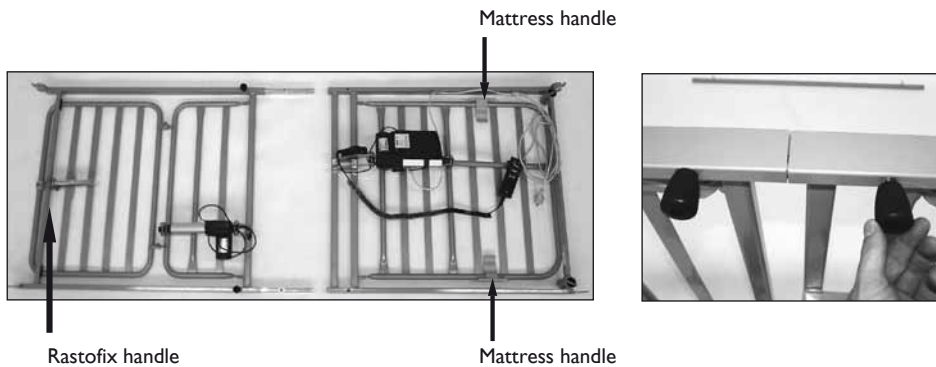

b) Bed end

- Turn the locking rings on the bed ends to the position "open".
- Latch the mattress support to the bed ends and press firmly into position.
- Turn the locking rings to the position "locked".

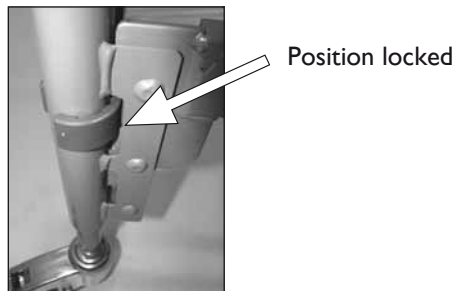

c) Control unit

The control unit is latched to the backrest motor.

The control unit is provided with a label with symbols showing where to connect the plugs:

- Backrest motor.
- Thigh section's motor (on 4-sectioned beds).
- Bed end motors.
- Hand control.

Wiring Etude Duo

In order to prevent the cables from being torn apart when activating the motors, it is critical that you follow the instructions below:

- 1) Connect the cable of the bed end motor (head) directly to the control unit and the bed end motor (foot) cable through the backrest motor support and into the control unit.
Only 4-sectioned beds: The plug of the thigh motor must be directed through the backrest motor support into the control unit.
- 2) Connect the mains cord to the 230V socket outlet.
- 3) Run the bed end motors to their top position.
- 4) Place the motor cable of the foot end on the hook at the foot end.
- 5) Run the backrest to its top position.
- 6) Place the bed end motor (head) cables on the hooks at the head end.
- 7) Fasten the locking cam to the control unit.

When working with the foot end, note that there is a risk of getting squeezed since the adjustable leg section is not firmly locked. Remember to remove the plug from the socket outlet when moving the bed.



Opening at the backrest motor support.



Wiring of the bed end motor (foot).



Wiring of the bed end motor (head).

Wiring Etude Medley

In order to prevent the cables from being torn apart when activating the motors, it is critical that you follow the instructions below:

- 1) Connect the cables of the bed end motors (head and foot end) directly to the control unit.
- 2) Wire the cable of the bed end motor (foot) and the leg motor through the pipe pins of the backrest motor.
- 3) Connect the mains cord to the 230V socket outlet (or the 24V cable and trafo on beds with external power supply).
- 4) Run the bed end motors to their top position.
- 5) Place the motor cable of the foot end on the hook at the foot end.
- 6) Run the backrest to its top position.
- 7) Place the bed end motor (head) cables on the hooks at the head end.
- 8) Fasten the locking cam to the control unit.

When working with the foot end, note that there is a risk of getting squeezed since the adjustable leg section is not firmly locked. Remember to remove the plug from the socket outlet when moving the bed.



Wiring of the leg section motor and bed end motor (foot) through the backrest motor pipe pin.



Wiring of the bed end motor (foot).



Wiring at the lifting motor, head end.

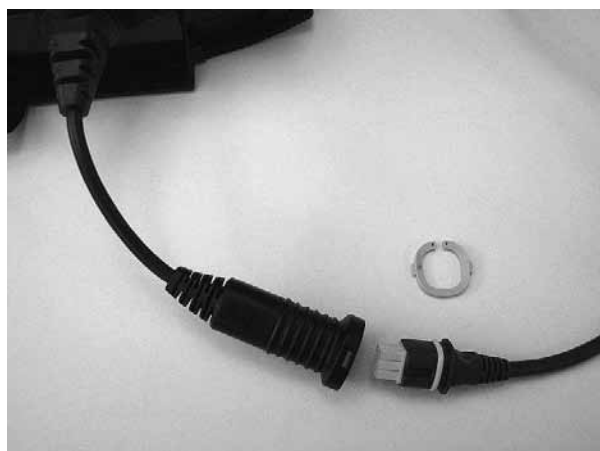

(On Medley with separate power supply) connect the wire from the power supply to the wire from the control unit and secure the connection with the enclosed wire lock

4. Fitting the accessories

(see illustration 3 in in front of the users manual)

Fitting the steel side rail

The side rail must be mounted with the release system at the head end of the bed.

The fork links on the side rail must be mounted according to the instruction on the side rail.

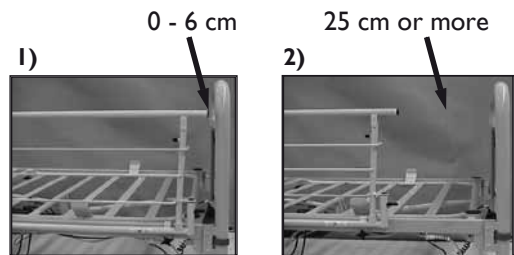

Tighten the side rail with 2 finger screws.

Mounting of wood kit and wooden side rail – *Etude Duo*



The lowest hinge position of the mattress support must not be used in connection with the wood kit and wooden side rail.

- 1) Dismount the small ferrule from the overpole of the bed end, and mount the pole by using the screws (do not tighten the screws). Refer to illustration A, B and C.

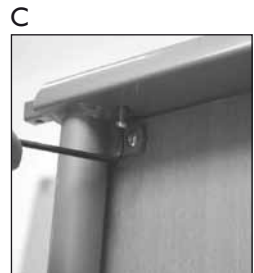
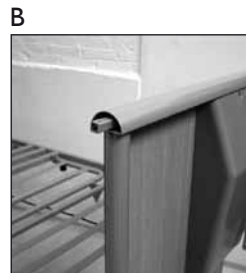
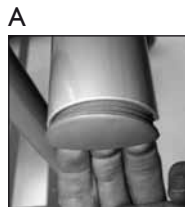

- 2) Install the wooden bar using the screws. Refer to illustration D, E and F.



- 3) Install the large ferrule and fully tighten the overpole screws. Refer to illustration G and H.

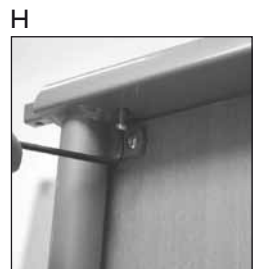

- 4) Raise the mattress support to about 1/4 of full lifting height.

- 5) Locate the side rail to both bed ends, and pull up the wooden side rail bar, until the locking pin engages with an audible click. Refer to illustration I.



Fitting the side rails on *Etude Medley*

The installation of steel- and wooden side rails are identical

- 1) The gliding system consists of 3 different parts which all must be installed simultaneously.
A disassembled gliding system is shown in illustration A.

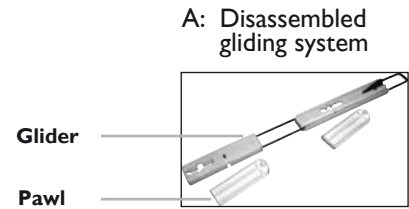

The two pawls are clipped onto the glider (B and C).

B: Removal

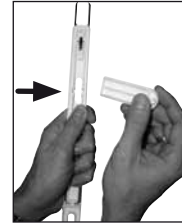

C: Installation



- 2) For a ergonomic working position and easier assembly, raise the bed to 1/3 of full height position. The gliding system of one bed end is guided into the bed end according to illustration D and E.

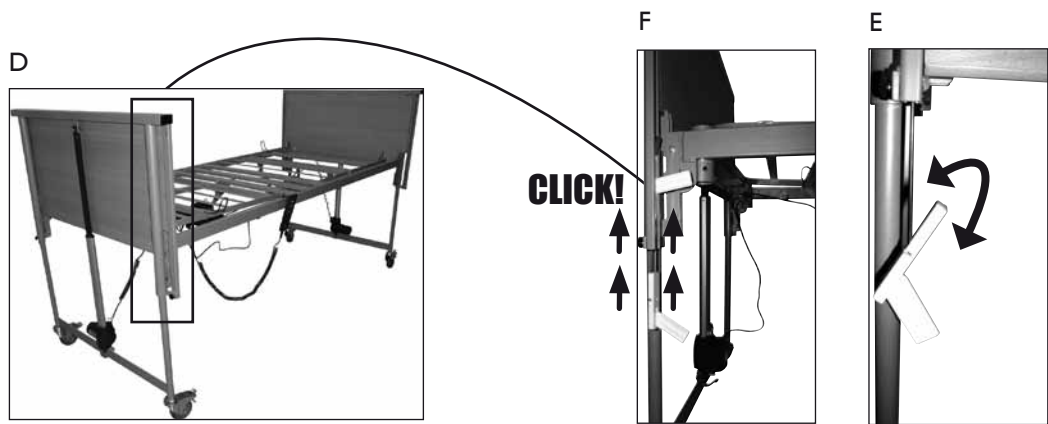

- 3) The upper side rail bar is installed according to illustration G.

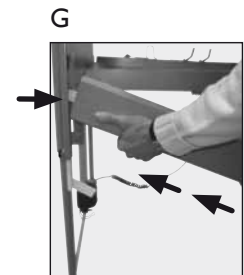

- 4) The gliding system in the opposite end are installed onto the upper side rail bar according to illustration H.

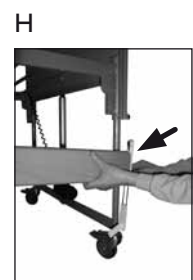

- 5) The side rail bar is raised until an audible click can be heard.
Please be sure, that the gliding system has engaged properly into the first hole.
(see illustration F and I).



- 6) The lower pawl is unfolded and the lower side rail bar is installed onto the pawl according to illustration E and J.

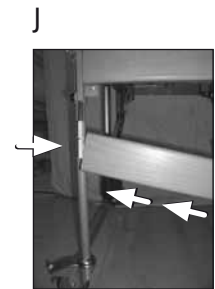

- 7) The lower pawl in the opposite end unfolded (see illustration E) and the lower side rail bar is then installed onto the lower pawl. Again, please ensure that pawls and gliders are completely engaged.
(See illustration K).

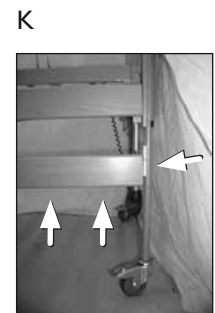

- 8) The locking finger screws are installed and tightened.



When lowering the side rails, there is a risk of entrapment between side rails and mattress support.



There is a risk entrapment on assembly and operation of the side rails.

Fitting the lifting pole

Remove the plug from the lifting pole tube at the head end of the bed where the lifting pole is to be placed.
Insert the lifting pole into the lifting pole tube and secure it with the finger screw.



Fitting the wooden cover on *Medley* bed ends

- 1) Remove the two upper end plugs from both bed ends.
- 2) The wooden cover is placed onto the existing bed end, the two distance pieces placed inside the bed ends, and fastened with the four enclosed furniture screws.

Fitting the Rastofix bracket

Rastofix bracket can be fitted between leg section and top frame in the foot end, by using the supplied two pipe pins.

Battery for emergency lowering

An emergency lowering battery can be fitted onto 4-sectioned beds.

A LED lamp on the battery indicates that charging can take place.

Please be aware that the emergency lowering battery can only be attached to the leg motor on 4-sectioned beds.

Preventive battery maintenance

The accumulator has to be exchanged after 4 years. Depending on how the battery is used, the exchange may have to take place earlier. Frequent, sudden discharges reduces the battery's life.

We recommend that the accumulator is tested at least once a year. The accumulator is not damaged by continuous connection to the mains.

Exchanging the battery

The accumulator must be exchanged with an accumulator of the same type or a mechanically and electrically compatible accumulator (12V – 1,3Ah). The accumulators must be new or charged at least every 6 months for maintenance purposes.



Warning! Old or faulty accumulators may generate an explosive gas mixture during charging. The accumulator box is provided with vents to ensure adequate ventilation of the box. The vents must not be blocked or covered, as this may result in pressure build-up and the risk of explosion.

Waste disposal

Old accumulators may be returned to *Invacare*[®], alternatively they are disposed of like car batteries.

5. Conversion from 3 to 4 sectioned mattress support (only *Etude Duo*)

The 3 sectioned bed is a 4 sectioned bed without leg section motor fitted.
Conversion to 4 sectioned can be done by using a conversion kit.

The conversion kit (order no. I443838) contains:

Motor
Hand control
Motor cable
Pipe pin

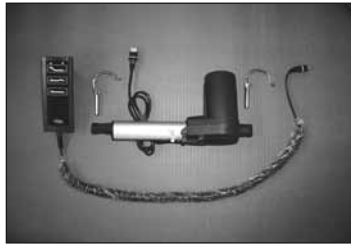

Assembly instruction:



1) Mount the motor on the high section.



2) Remove the locking cam from the control unit (if necessary use a little screwdriver).



3) Remove the blind plug.

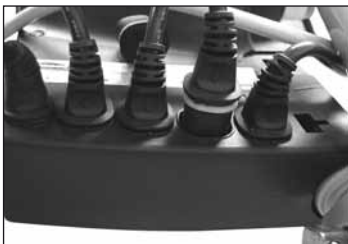

4) Connect the motor to the control unit.



5) Release the safety lock for the plug to exchange the hand control on the ACP-box.



6) Exchange the hand control.





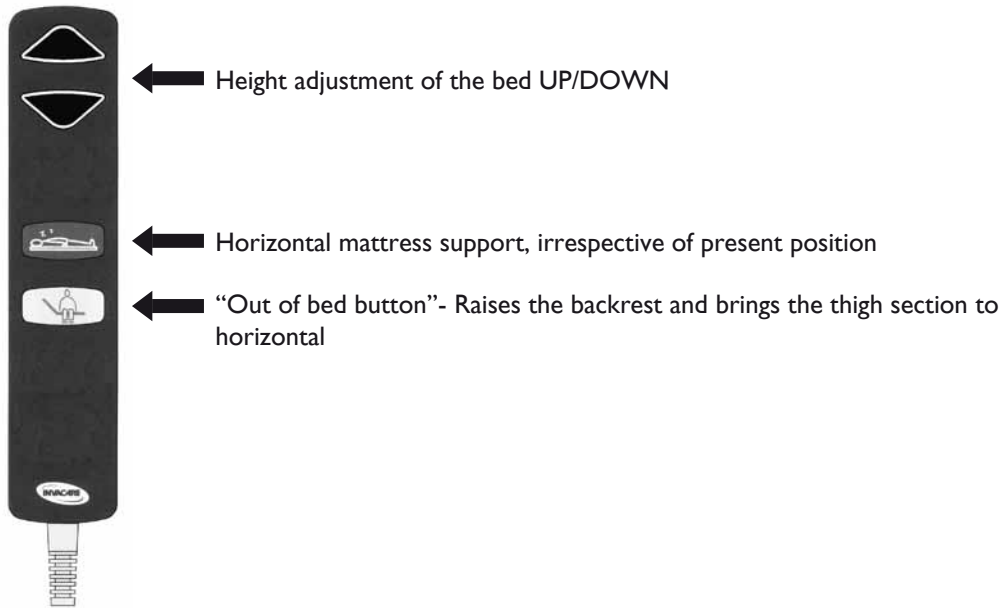

6. Operating the bed

6a. Operating beds with 3-sectioned mattress support

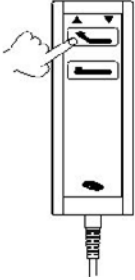
The bed can be equipped with this type of hand control (Soft Control):

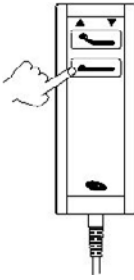

or with this type of hand control (HB 70):





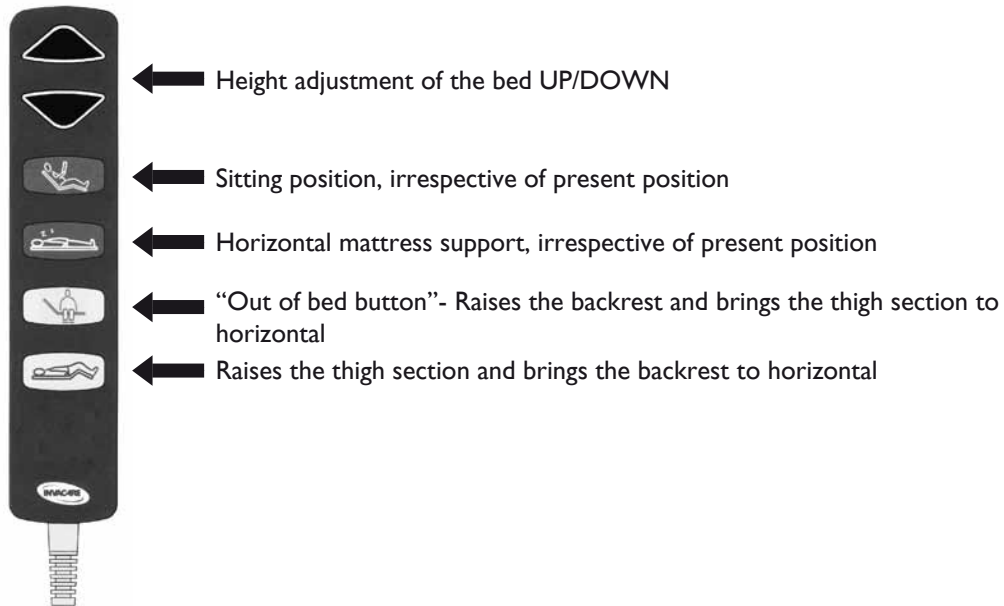

<p>Backrest up</p>  <p>Button with the symbol shown above. Push the left-hand side of the button.</p>	 	<p>Backrest down</p>  <p>Button with the symbol shown above. Push the right-hand side of the button.</p>
<p>Height up</p>  <p>Button with the symbol shown above. Push the left-hand side of the button.</p>	 	<p>Height down</p>  <p>Button with the symbol shown above. Push the right-hand side of the button.</p>

6b. Operating beds with 4-sectioned mattress support

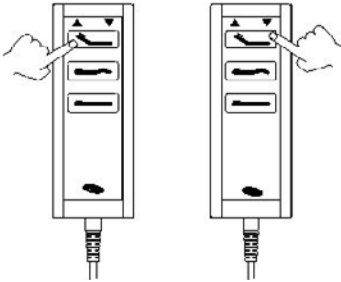
The bed can be equipped with this type of hand control (Soft Control):

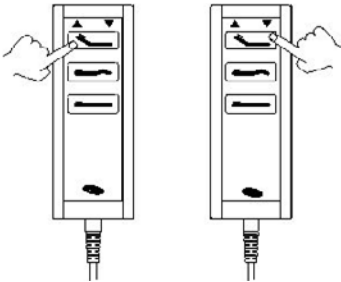

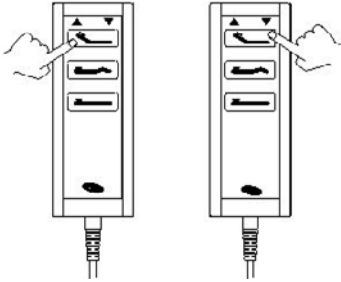
or with this type of hand control (HB 70):

<p>Backrest up</p>  <p>Button with the symbol shown above. Push the left-hand side of the button.</p>		<p>Backrest down</p>  <p>Button with the symbol shown above. Push the right-hand side of the button.</p>
<p>Thigh section up</p>  <p>Button with the symbol shown above. Push the left-hand side of the button.</p>		<p>Thigh section down</p>  <p>Button with the symbol shown above. Push the right-hand side of the button.</p>
<p>Height up</p>  <p>Button with the symbol shown above. Push the left-hand side of the button.</p>		<p>Height down</p>  <p>Button with the symbol shown above. Push the right-hand side of the button.</p>

Or with this type of hand control (HL 80 with integrated ACP function):



← **Adjustment of backrest - up/down**
Use the button with the symbol shown on the left

← **Adjustment of the thigh section - up/down**
Use the button with the symbol shown on the left

← **Height adjustment of mattress section - up/down**
Use the button with the symbol shown on the left



← **Key for blocking and unblocking the electrical functions**
Insert the key below each button to respectively block and unblock the hand control functions

6c. Adjustment of the leg section

(see illustration 4 in the back of the users manual)

The leg section can be adjusted **up/down** manually by using the handle located close to the bedend.

Up: Lift the leg section.

Down: Lift the leg section all the way up and then lower it.

6d. Operation of brakes

(see illustration 6 in the back of the users manual)

Each of the bed's 4 castors is provided with brakes for both lengthwise and crosswise locking. The brake is foot-operated.

When the bed is positioned correctly, at least one castor at the head end and one castor at the foot end must be locked.

1) **Braking:** Step on the pedal.

2) **Releasing the brake:** Step on the release pedal.

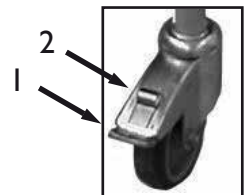

6e. Tilt function

Both 3 - and 4 - sectioned beds can be equipped with hand controls that activate the tilt of the mattress support.



The tilt function must only be operated by medically trained persons - otherwise, there is a risk of injury to the patient's health.

Hand controls with tilt activating can be ordered from *Invacare*® - please refer to the section "Order numbers for accessories".



Always leave the bed in the lowest position. Otherwise there is a risk of entrapment due to accidental lowering of the mattress support. A person under the bed can be seriously injured during height adjustments. There is also a risk of entrapment between the leg section or backrest and bed frame when the backrest/leg section is lowered. Furthermore, there is a risk of entrapment between bed end and wheels when the mattress support is lowered.



There is a risk of entrapment between the backrest and the cross rail on the head end of the mattress support. There is also a risk of getting squeezed between the leg section and the cross rail on the foot end of the mattress support when the backrest/leg section is lowered.

7. Emergency lowering of the backrest and/or thigh section

(see illustration 5 in the back of the users manual)

An emergency release of the mattress support may be necessary in case of e.g. a power- or motor failure. An emergency release of the height adjustment is NOT possible.

Remove the plug from the mains before emergency release of the mattress support.



1) Hold the backrest.



2) Remove the pipe pin from the backrest motor.

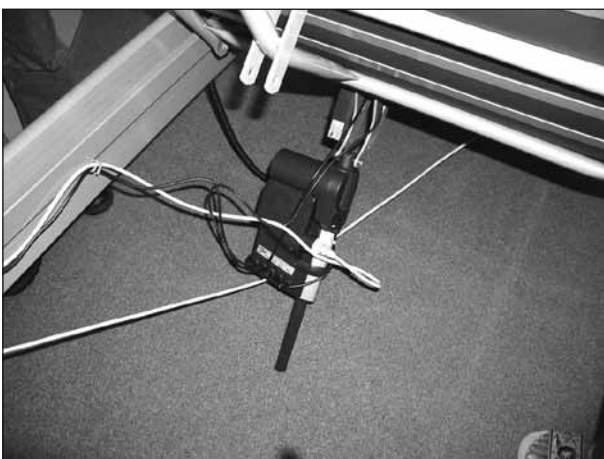

3) Lower the backrest motor.

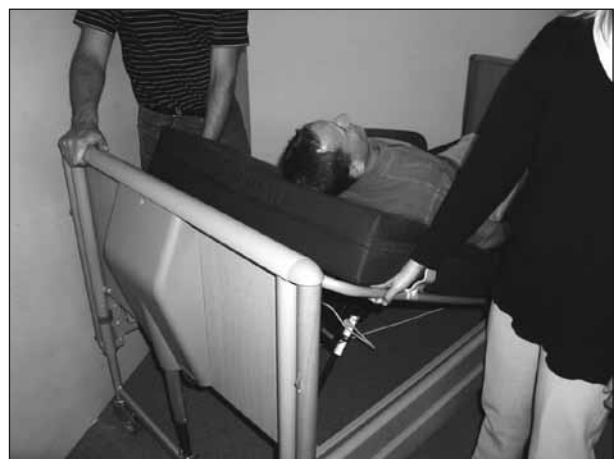

4) Lower the backrest.



A **minimum of 2 persons** are required to emergency release a mattress section. Both persons hold the mattress section. One person pulls out the pipe pin. Both slowly lower the mattress section until it is completely down.

8. Operating the accessories

8a. Accessories *Etude Duo*

Operation of steel side rails

(see illustration 7 in the back of the users manual)

Up: Pull the top tube on the side rail towards the end where the release system is placed.

Down: Press the release button down while pulling the top tube away from the release system.

Operation of wooden side rails *Scala Mona*

Up: Pull up the top side rail bar until the locking pin engages with an audible click.



Down: Lift the top side rail bar and press the latches to disengage the locks. Lower the side rail.



There is a risk of entrapment when operating the side rails.

8b. Accessories *Etude Medley*

Operation of side rails - steel and wood

Up: Pull up the top side rail bar until the locking pin engages with an audible click.



Down: Lift the top side rail bar and press the latches inside the rail to disengage the locks. Lower the side rail.



There is a risk of entrapment when operating the side rails.

Adjusting the height of the lifting pole handle

Loosen the cord as shown in illustration A. The lifting handle can now be adjusted to the desired height. Press the cord together as shown in illustration B, and check that the cord is locked in the cord lock by pulling the handle.

Please notice that the string between the pole handle and lifting pole can be adjusted under consideration of the mattress height and the beds inclinations.

For a flexible use, we recommend, that both upper and lower bows in the handle are used.



A



B

The distance between the lifting pole and the mattress:

Etude

Mattress at 10 cm height: 55-78 cm

Mattress at 12 cm height: 53-76 cm



Always position the lifting pole in such a way that the handle extends inwards across the bed. If the lifting pole is used while the handle has been turned away from the bed, the bed can tip when used.

Fitting the mattress support extension

Disassemble the bed and remove the inserts. Mount the mattress support extension and the two mattress support parts, and reassemble the bed (see illustration 2a in the front of the users manual).

Choice of mattress

The standard mattress size for **Etude** bed is 90x200 cm. We recommend a mattress density of at least 35 kg/m³.

When the mattress support is positioned in the upper hinge position, a mattress of up to 18 cm can be used on **Etude Duo** (standard steel or wooden side rail), and up to 12 cm on the **Etude Medley** (standard steel or wooden side rail).

When the mattress support is positioned in the lower hinge position, a mattress of up to 18 cm can be used on **Etude Duo** (only with steel side rail), and up to 18 cm on the **Etude Medley** (standard steel or wooden side rail).



Metal side rails with extra height can be offered as an accessory, thus making mattress heights of up to 30,5 cm for **Etude Duo** and 22 cm for **Etude Medley** possible.

Mattress heights (cm)				
Bed	Etude Duo		Etude Medley	
Type of siderail	Wooden siderail	Steel siderail	Wooden siderail	Metal siderail
Upper mattress support hinge position	10 – 18	10 – 18	10 - 12	10 - 12
Lower mattress support hinge position	Not allowed/possible	10 – 18	10 - 18	10 - 18

9. Dismantling the *Etude* bed

- Remove side rails and lifting pole.
- Bring the bed to its lowest position and adjust all mattress support sections to horizontal position.
- Disconnect the mains cord (or the external power supply) from the socket outlet, and roll the cord onto the cable hook at the head end of the bed.
- Remove the locking cam from the control unit, by means of a flat bladed screwdriver.
- Pull out the cables for all motors.
- Remove the mattress support from the bed ends.
- Disassemble the mattress support.



10. Order numbers

10a. Order numbers *Etude Duo*

50.57600.M0	Lifting pole
1478731-0101	Conversion kit (side rail, wooden pole and installation components) for conversion from steel to wooden side rail Scala Mona 2 and Lisa 2
1432784-0152	Steel side rail Scala Basic (1 pair)
1432781-0152	Steel side rail Scala Medium - suitable for mattress heights of 9 - 22 cm (1 pair)
1432793-0152	Steel side rail Scala Decubi - suitable for mattress heights of 22 - 31 cm (1 pair)
1446379-0152	Extended mattress support +10 cm
1446380-0152	Extended mattress support +20 cm
1497774-0101	Extended wooden side rail Scala Mona 2 +10 cm (1 pair)
1495719-0101	Extended wooden side rail Scala Mona 2 +20 cm (1 pair)
50.55290.M0/L+R	Extended steel side rail 5529 +20 cm (1 pair)
1417510-0152	Support handle 25x80 cm, 1 pcs.
1417511-0152	Support handle 40x30 cm, 1 pcs.
021963.M0	Support handle 40x50 cm, 1 pcs.
021964.M0	Support handle 25x30 cm, 1 pcs.
1417512-0152	Support handle 40x95 cm, 1 pcs.
1443838	Upgrade kit from 3- to 4- sectioned mattress support (thigh section motor, cables and hand control)
1427838-7032	Transport fitting for Etude beds
215989-7035	Mattress retainer
217996-7035	Rastofix-handle (at bed end)
1423845	Hand control HB70 for 3 sectioned beds, with tilt function
1423846	Hand control HB70 for 4 sectioned beds, with tilt function

I0b. Order numbers *Etude Medley*

50.57600.M0	Lifting pole
I491224-0101	Wooden side rail Etude Medley version (4 parts)
I510567-0101	Wooden cover for Etude Medley bed ends, beech
I491226-0152	Steel side rail Etude Medley version (4 parts)
I432784-0152	Steel side rail Scala Basic (1 pair)
I432781-0152	Steel side rail Scala Medium - suitable for mattress heights of 9 - 22 cm (1 pair)
I446380-0152	Extended mattress support +20 cm
I491305-0101	Extended wooden side rail Etude Medley version (4 parts) +20 cm
I417510-0152	Support handle 25x80 cm, 1 pcs.
I417511-0152	Support handle 40x30 cm, 1 pcs.
021963.M0	Support handle 40x50 cm, 1 pcs.
021964.M0	Support handle 25x30 cm, 1 pcs.
I417512-0152	Support handle 40x95 cm, 1 pcs.
I493223	Transport fittings, Medley, unpainted
I427838-7032	Transport fitting for Etude beds
I491299-7042	Mattress retainer
I423846	Hand control HB70 for 4 sectioned beds, with tilt function
I509466-7016	External power supply (transformer) with wire
I427714	Rastofix bracket for leg section

I 1. Cleaning and disinfection

Remove the mains plug from the socket outlet before cleaning.

The **Etude** bed does not tolerate cleaning in an automatic washing plant or using water-jet based cleaning equipment.

The bed should be washed down using a sponge, cloth or brush. Use ordinary disinfecting detergents.

When disinfecting only use spray or wiping methods. Only officially recognized disinfectants must be used.

Dry the bed after cleaning.

Never use acids, alkalines or solvents such as acetone or cellulose thinner.

The hand control, motors and control unit may be washed with brush and water, but not with pressurized water.



If the backrest is raised, be careful not to lower it unintentionally, as there is a risk of entrapment between the backrest and the top frame.

I 2. Maintenance and servicing

Service and maintenance of the bed must only be performed by personnel who have received the necessary instruction or training.

With normal daily use, service must be carried out according to the service schedule after 2 years use and thereafter every second year.

We recommend to use medical clean oil for lubrication (e.g. SCAN-WO, order no. 823239).

A service contract may be available in countries where *Invacare*[®] has own sales companies.

Futhermore, *Invacare*[®] offers courses in service and maintenance - please consult your local *Invacare*[®] company.

A spare part list can be obtained from *Invacare*[®]. Please note that electrical components can not be repaired.

We recommend to carry out cleaning and disinfection as well as maintenance and service prior to each re-issue of the bed into the community.

13. Maintenance chart

Only personnel who have received the necessary instruction or training must perform service and maintenance of the *Etude* beds.

S/N (located on mattress support): _____

The bed should be serviced and tested by every relocation.

Date:

Initials:

Name (Print) and Signature

Visual inspection	In order	Unfunctional
The users manual and identification label is present.		
Visual inspection of all parts of the bed. (Plastic deformation and/or wear and tear of welded joints).		
All surfaces should be smooth and without burrs and sharp edges.		
Check the rivet in the bedends - rivets shall be completely fastened.		
Check the Rastofix fitting		
Visual inspection of all electrical equipment for damages.		
Check that mains cord, the plugs (and the external power supply) are undamaged.		
Check all remaining cables for damages. Also check the running of the cables.		
Mains cable as well as other electrical cables are placed in positions that prevents cutting, squeezing and other possible mechanical damages on the cables.		
Make sure that the transport hook in the head bed end, used to protect the cables during transportation, is undamaged.		
Check that there are no marks or scratches in the paint work on the frame and in the weldings - damaged paint must be repaired.		

Function inspection	In order	Unfunctional
All motors runs without defects, with normal speed and sound.		
Check the ACP blocking function.		
Check the motor's end stop.		
Test the side rails' fixations and locking/movement. The component should be undamaged and function without faults.		
Check the castors (braking and free rolling).		
The following parts must be lubricated: - Centers of rotation (motors and mattress support parts). - Centers of rotation of Rastofix fittings. (Lubricate with medically clean oil, e.g. KEW-WO 50). NB! The side rails' gliding system must not be lubricated with oil - otherwise the side rail bars will move sluggishly.		

14. Disposal

This product has been supplied from an environmentally aware manufacturer that complies with the Waste Electrical and Electronic Equipment (WEEE) Directive 2002/96/CE.

This product may contain substances that could be harmful to the environment if disposed of in places (land fills) that are not appropriate according to legislation.

The »crossed out wheellie bin« symbol is placed on this product to encourage you to recycle wherever possible.

Please be environmentally responsible and recycle this product through your recycling facility at its end of life.

All wooden parts must be dismantled and sent for incineration.

All electrical parts must be dismantled and disposed of as electrical waste.

Steel parts and castors must be disposed of as waste metals.

Plastic parts must be sent for incineration or recycling.

Waste disposal must comply with the laws and regulations pertaining waste handling in each country.

15. Trouble-shooting the electrical system

Service and maintenance of the **Etude** must only be performed by personnel who have received the necessary instruction or training. Please ensure that;

- 1) Mains power cord (or external power supply) is plugged in
- 2) Motor cables correctly fitted
- 3) There is no visual damage to the cables
- 4) Hand control is correctly mounted
- 5) ACP-box not in »Lock-position« (if fitted)

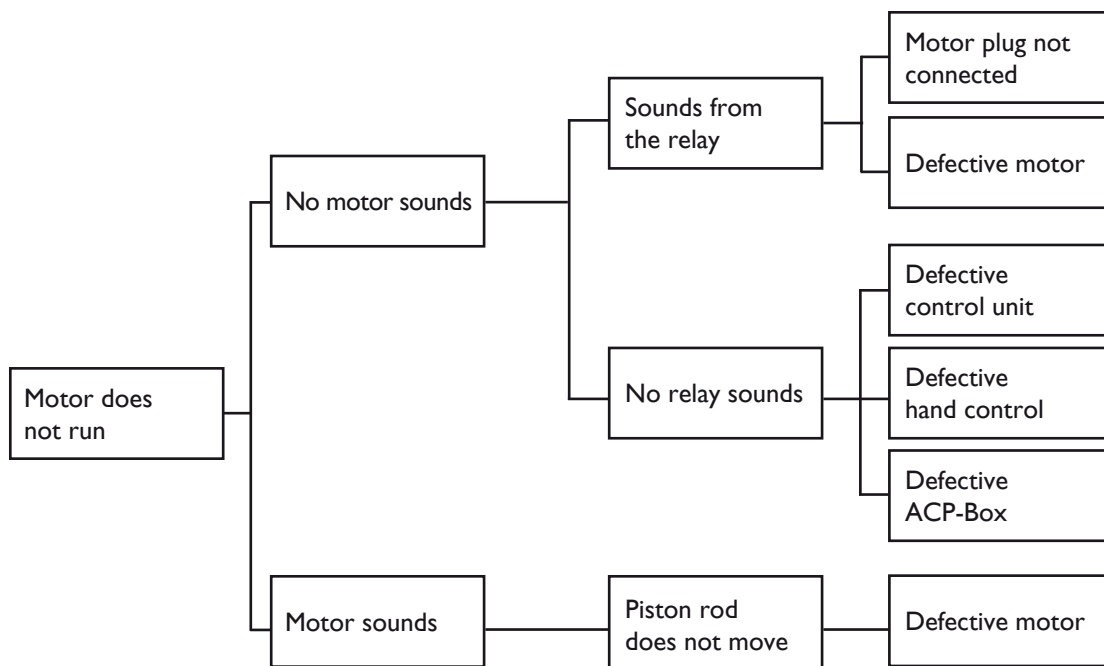

16. Replacement of control unit and cables



- 1) The control unit can be removed by taking away the retaining clips from the backrest motor.

Retaining clips



- 2) Pull the control unit sideways, away from the motor.



- 3) Remove the locking cam by unlatching the clips, and remove all motor and hand control plugs from the control unit. Installation is reverse of removal.

Installation of control unit - *Etude Duo*

On *Etude Duo* all plugs should face upwards on the control unit.

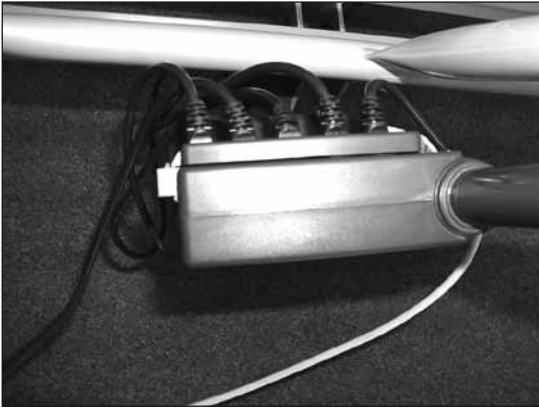

GB

Installation of control unit - *Etude Medley*

On *Etude Medley* all plugs should face downwards on the control unit.

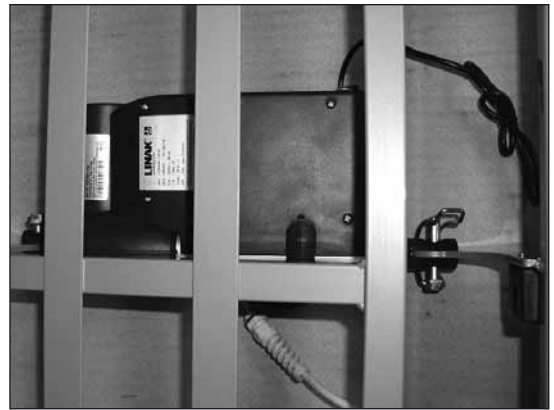



17. Technical specifications

All measurements are stated in cm. All angles are stated in degrees. All measurements and angles are stated without tolerances.

Invacare® reserves the right to change the stated measurements and angles without previous warning. (see illustration 8 in the back of the users manual).

Voltage supply: 230V ~ ±10%, 50 Hz
Max. current input: 1 A
Voltage output: 24V ~ max. 70 VA
Intermittent: 10%, max. 6 min/h (periodic motor operation)
Protection class: IP 54
Insulation class: II, type B

Alternating current: 
Direct current: 

Direct current:

The patient is not separated from the ground and the chassis



Double insulated



The bed is not provided with a mains switch, so the mains plug is the only separation from the mains.



= 180 kg Max. load (SWL) = (patient + mattress + siderail + lifting pole + other equipment)

The product should be reused where possible.



Lifting pole max. load (SWL): 80 kg

Sound level: 45-50 dB(A)

Potential equalization.



18. Weights

18a. Weights *Etude Duo*

Etude Duo bed end, steel - 1 pcs.	16,0 kg
Etude Duo bed end, wood - 1 pcs.	18,5 kg
Mattress support, head end	22,0 kg
Mattress support, foot end, 3-sectioned	17,0 kg
Mattress support, foot end, 4-sectioned	22,0 kg
Steel side rail Scala Basic - 1 pcs.	7,0 kg
Wooden side rail Scala Mona 2 - 1 pcs.	7,5 kg
Lifting pole.	7,0 kg
Mattress support extension (+10 cm)	3,0 kg
Mattress support extension (+20 cm)	5,5 kg

3-sectioned bed, complete excluding side rails and lifting pole, with Etude Duo bed end, steel	71,0 kg
4-sectioned bed, complete excluding side rails and lifting pole, with Etude Duo bed end, steel	76,0 kg

3-sectioned bed, complete, including side rails and lifting pole, steel	92,0 kg
4-sectioned bed, complete, including side rails and lifting pole, steel	97,0 kg
3-sectioned bed, complete, including side rails and lifting pole, wood	98,0 kg
4-sectioned bed, complete, including side rails and lifting pole, wood	103,0 kg

18b. Weights *Etude Medley*

Etude Medley bed end, steel - 1 pcs.	16,0 kg
Mattress support, head end	20,0 kg
Mattress support, foot end.	17,0 kg
Steel side rail - 1 rail.	5,0 kg
Wooden side rail - 1 rail.	4,0 kg
Lifting pole.	7,0 kg
Mattress support extension (+20 cm)	5,5 kg
Etude Medley Select bed end wooden cover, 1 pcs.	6,5 kg

4-sectioned bed, complete excluding side rails and lifting pole, with Etude Medley bed end, steel	69,0 kg
---	---------

4-sectioned bed, complete, including side rails and lifting pole, steel without Select covers	86,0 kg
4-sectioned bed, complete, including side rails and lifting pole, wood, without Select covers.	84,0 kg

Etude Duo

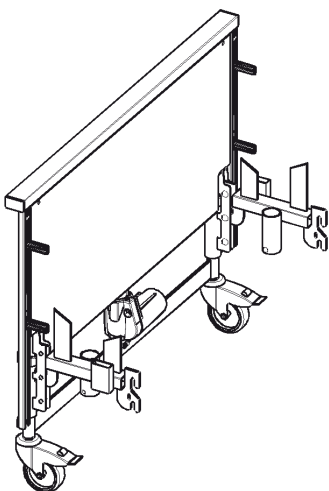

1

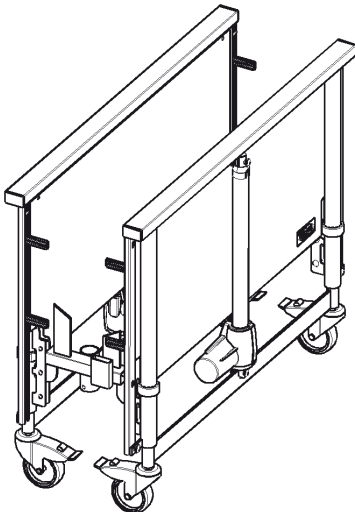

2

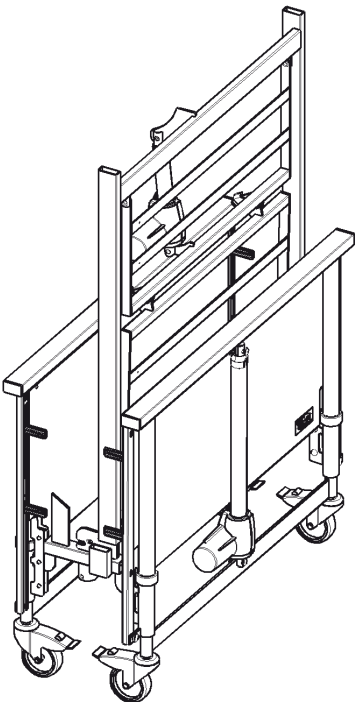

3

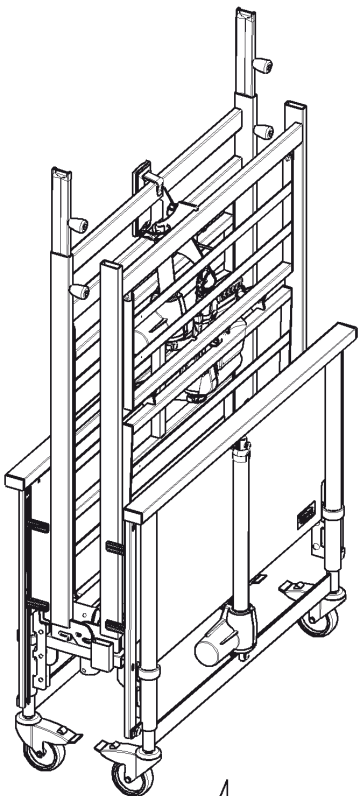

4

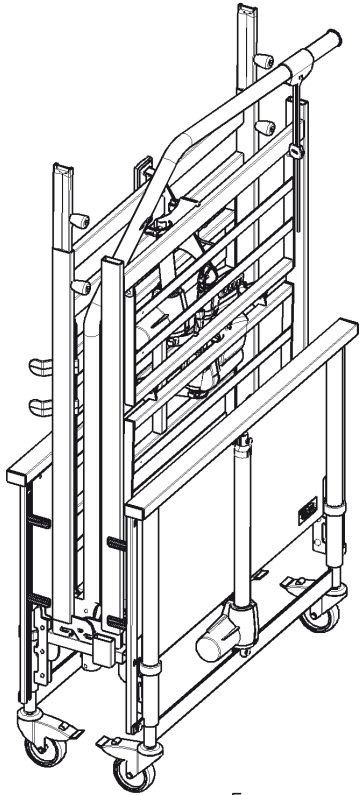

5

Etude Medley

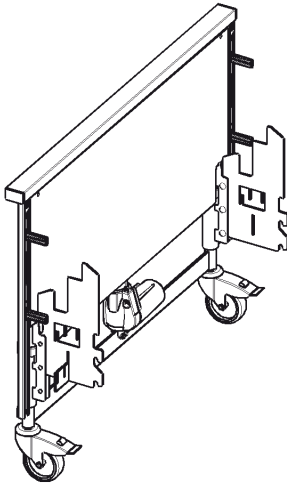

1

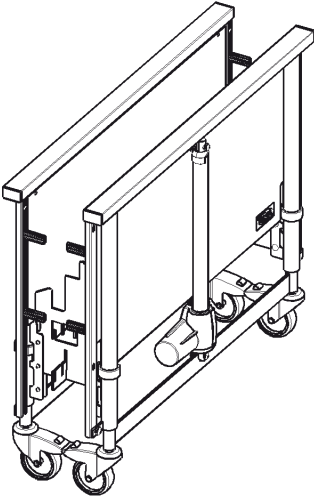

2

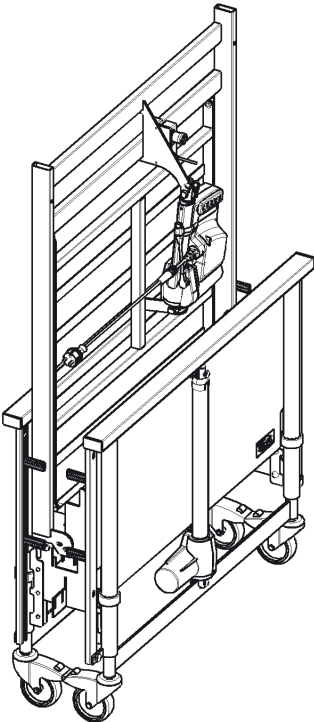

3

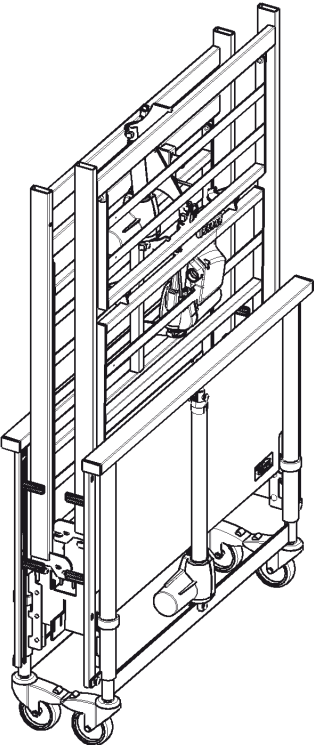

4

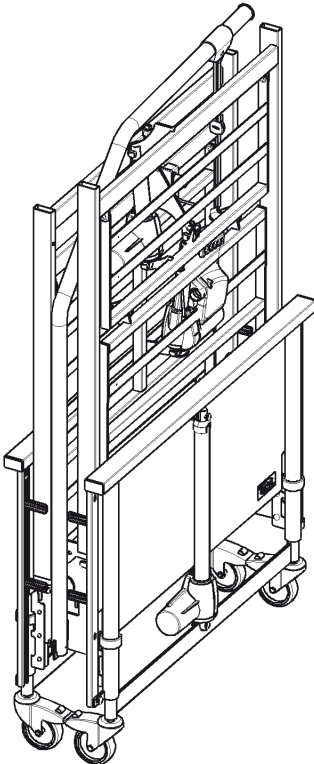

5



Yes, you can.®

Customer Sales and Service

Denmark

INVACARE A/S

Sdr. Ringvej 37
DK-2605 Brøndby
Phone: +45 36 90 00 00
Fax: +45 36 90 00 01
www.invacare.dk
denmark@invacare.com

Sweden & Finland

INVACARE AB

Fagerstagatan 9 / Box 66
S-163 91 Spånga
Phone: +46 8 761 70 90
Fax: +46 8 761 81 08
www.invacare.se
sweden@invacare.com

Norway & Iceland

INVACARE AS

Grensesvingen 9
Postbox 6230 Etterstad
N-0603 Oslo
Phone: +47 22 57 95 00
Fax: +47 22 57 95 01
www.invacare.no
norway@invacare.com

Spain

INVACARE S.A.

C/Areny S/N
Poligon Industrial de Celrà
E-17460 Celrà (Girona)
Phone: +34 972 49 32 00
Fax: +34 972 49 32 20
www.invacare.es
contactsp@invacare.com

Switzerland

MOBITEC REHAB AG

Benkenstrasse 260
CH-4108 Witterswil
Phone: +41 61 487 70 80
Fax: +41 61 487 70 81
switzerland@invacare.com

Invacare® EC-Høng A/S

Ident. no.: 1492780

Version: 05

Date: 01.2010

Belgium & Luxemburg

INVACARE N.V.

Autobaan 22
B-8210 Loppem, Brügge
Phone: +32 50 83 10 10
Fax: +32 50 83 10 11
www.invacare.be
belgium@invacare.com

Netherlands

INVACARE B.V.

Celsiusstraat 46
NL-6716 BZ Ede
Phone: +31 318 695 757
Fax: +31 318 695 758
www.invacare.com
nederland@invacare.com
csede@invacare.com

Germany

INVACARE® AQUATEC GmbH

Alemannenstrasse 10
D-88316 Isny
Phone: +49 75 62 7 00 0
Fax: +49 75 62 7 00 66
www.invacare-aquatec.de
info@invacare-aquatec.com

Portugal

INVACARE Lda

Rua Estrada Velha 949
P-4465-784 Leça do Balio
Phone: +351 225 1059 46/47
Fax: +351 225 1057 39
www.invacare.pt
portugal@invacare.com

Australia

INVACARE Australia Pty Ltd

1 Lenton Place, North Rocks
NSW 2151
Phone: +61 2 8839 5333
Fax: +61 2 8839 5353
www.invacare.com.au
sales@invacare.com.au

3rd party certified
according to
EN ISO 9001
EN ISO 13485

France

INVACARE Poirier S.A.S

Route de St. Roch
F-37230 Fondettes
Phone: +33 2 47 62 64 66
Fax: +33 2 47 42 12 24
www.invacare.fr
contactfr@invacare.com

Italy

INVACARE MECC SAN S.R.L.

Via dei Pini 62
I-36016 Thiene (VI)
Phone: +39 0445 38 00 59
Fax: +39 0445 38 00 34
www.invacare.it
italia@invacare.com

United Kingdom & Ireland

INVACARE LTD

Pencoed Technology Park,
Pencoed
UK-Bridgend CF35 5HZ
Phone: +44 1 656 776 200
Fax: +44 1 656 776 201
www.invacare.co.uk
uk@invacare.com
ireland@invacare.com

New Zealand

INVACARE NZ

4 Westfield Place,
Mt. Wellington
Auckland
Phone: +64 9 917 3939
Fax: +64 9 917 3957
www.invacare.co.nz
sales@invacare.co.nz

Austria

MOBITEC MOBILITÄTSHILFEN GmbH

Herzog Odilostrasse 101
A-5310 Mondsee
Phone: +43 6232 5535 0
Fax: +43 6232 5535 4
www.mobitec-austria.com
austria@invacare.com

Manufacturer:

INVACARE EC-Høng A/S

Østergade 3
DK-4270 Høng
www.invacarebeds.dk