

Küschall® K-Series



en Active wheelchair
Service Manual



PROVIDER: Keep this manual.
The procedures in this manual MUST be performed by a qualified technician.

Küschall®
UNLIMIT YOUR WORLD

Contents

1 General	4
1.1 Introduction	4
1.2 Symbols in This Manual	4
2 Safety	5
2.1 General Safety Information	5
2.2 Personal safety information	5
2.3 General repair information	5
3 Product Overview	7
3.1 Main parts of the wheelchair	7
3.2 Dimensions	7
4 Servicing	8
4.1 Inspection checklist	8
4.2 Spare parts	8
5 Reconditioning	9
5.1 Cleaning	9
5.2 Disinfection	9
5.3 Materials	9
5.4 Reconditioning scheme	10
6 Instructions	11
6.1 Frame overview	12
6.2 Seat	13
6.2.1 Seat width (SW)	13
6.2.2 Seat depth (SD)	13
6.2.3 Seat angle (SA)	13
6.2.4 Front seat-to-floor height (FSTF)	13
6.2.5 Rear seat-to-floor height (RSTF)	13
6.2.6 Adjusting the tipping point	15
6.2.7 Installing a suspension	16
6.3 Backrest	17
6.3.1 Tension adjustable backrest	17
6.3.2 Backrest height (BH)	18
6.3.3 Backrest angle (BA)	19
6.3.4 Installing/adjusting the release cord	20
6.3.5 Replacing the backrest tube	21
6.3.6 Replacing the handle	22
6.3.7 Replacing the foldable Push Handle	22
6.4 Footrests	23
6.4.1 Replacing the footrest	23
6.4.2 Adjusting the footrest height	23
6.4.3 Installing/replacing the foot plate	24
6.4.4 Replacing the angle-adjustable footrest	24
6.4.5 Replacing the high-mounted footrest	24
6.4.6 Installing the flip-up footrest	26
6.5 Sideparts	27
6.5.1 Clothes-guard / Mudguard	27
6.5.2 Installing the tubular armrest	31
6.5.3 Installing/adjusting the siderest	31
6.6 Castors	32
6.6.1 Replacing the castor wheel	32
6.6.2 Replacing the castor fork	33
6.7 Rear Wheels	33
6.7.1 Ensuring the rear wheels are parallel	33
6.7.2 Adjusting the Removable Axle	34
6.7.3 Installing/adjusting the rear wheel extension	34
6.7.4 Changing the wheel camber / Installing and adjusting an axle	34
6.7.5 Repairing or changing an inner tube	37
6.7.6 Replacing a solid tire	37
6.7.7 Replacing rear wheel spokes	37
6.8 Parking brakes	38
6.8.1 Installing the parking brake	38
6.8.2 Adjusting the parking brake	38
6.9 Options	39
6.9.1 Installing/adjusting the antitipper	39
6.9.2 Installing/adjusting the transit wheels	40
6.9.3 Installing the posture belt	41
6.9.4 Installing the positioning belt	41
6.9.5 Attaching the snap hook symbol labels	41

1 General

1.1 Introduction

This document contains important information about assembly, adjustment and advanced maintenance of the product. To ensure safety when handling the product, read this document and the user manual carefully and follow the safety instructions.

Find the user manual on Invacare's website or contact your Invacare representative. See addresses at the end of this document.

Invacare reserves the right to alter product specifications without further notice.

Before reading this document, make sure you have the latest version. You find the latest version as a PDF on the Invacare website.

For pre-sale and user information, see the user manual.

For more information about the product, for example product safety notices and product recalls, contact your Invacare representative. See addresses at the end of this document.

1.2 Symbols in This Manual

Symbols and signal words are used in this manual and apply to hazards or unsafe practices which could result in personal injury or property damage. See the information below for definitions of the signal words.

**WARNING**

Indicates a hazardous situation that could result in serious injury or death if it is not avoided.

**CAUTION**

Indicates a hazardous situation that could result in minor or slight injury if it is not avoided.

**IMPORTANT**

Indicates a hazardous situation that could result in damage to property if it is not avoided.

**Tips**

Gives useful tips, recommendations and information for efficient, trouble-free use.

**Tools**

Identifies required tools, components and items which are needed to carry out certain work.

2 Safety

2.1 General Safety Information



WARNING!

Risk of injury or damage to property

- The procedures in this manual must only be performed by a qualified technician.
- Use only original options and spare parts.
- Do not handle this product or any available optional equipment without first completely reading and understanding these instructions and any additional instructional material such as user manuals, installation manuals or instruction sheets supplied with this product or optional equipment.
- After each assembly, check that all fittings are properly tightened and that all parts have the correct function.



WARNING!

Risk of contamination

- Clean and disinfect the product before servicing.



IMPORTANT!

- Assembly of optional equipment might not be described in this service manual. Refer to the manual, delivered with the optional equipment.
 - Additional manuals can be ordered from Invacare. See addresses at the end of this document.
 - Due to regional differences, refer to your local Invacare catalog or website for available optional equipment or contact your local Invacare representative. See addresses at the end of this document.



IMPORTANT!

- Some replacement parts are only available as a kit. Always use the complete new kit when replacing a part.
 - Spare parts can be ordered from Invacare. Refer to your local Invacare website to access the electronic spare parts catalogue (ESPC).



IMPORTANT!

- Refer to the user manual of this product for information on
 - Technical data
 - Product components
 - Labels
 - Additional safety instructions



The information contained in this document is subject to change without notice.

2.2 Personal safety information

These safety instructions are intended to help avoid accidents during work and must be observed under all circumstances.

All employees coming into contact with contaminated products must regularly consult a company doctor. Work clothing and personal protective equipment must be available in necessary quantities and be in proper condition. Reliable hand and surface disinfection must be ensured.



WARNING!

Risk of contamination

- Clean and disinfect the product before carrying out repairs.

2.3 General repair information

Repairs require a high level of expertise. These assembly instructions therefore break down the various tasks into 3 categories:

Requirement	Symbol
Easy – technical understanding required	■□□
Medium – technical knowledge required	■■□
Difficult – technical knowledge and expertise in assembling required	■■■

The required tools and their sizes are listed before the instructions.

- !** **IMPORTANT!**
- If possible, continue to use the old identification label; if this is not possible, the new identification label must contain the same information and the old serial number. (Replacement of spare parts with serial numbers).
 - When components are replaced it is necessary to ensure the traceability of the components replaced.
 - If screws with thread locker are loosened, these must be replaced with new screws with thread locker. Alternatively, new thread locker must be applied.
 - If screws with circlip rings are loosened, these must be replaced with new ones.
 - Parts that become damaged during removal must be replaced with new ones.
 - All bolts must be tightened with the torque specified in the following instructions. Liquid high-strength and low-strength adhesives are available. After the torque specifications, the adhesive to be used (high-strength or low-strength) is indicated in brackets.

Fastening with hexagon socket bolts

<p>Hexagon socket bolts are not designed to withstand an excessive application of force. When tightening or undoing a hexagon socket bolt, force should be applied to the nut wherever possible to avoid damaging the bolt.</p>	
<p>Tightening and undoing</p> <p>Turn the nut using a socket spanner (only use an open-end spanner if there is insufficient space), using the Allen key simply to stop the bolt turning.</p>	
<p>Tightening and undoing when no nut is present</p> <p>If a hexagon socket bolt is screwed directly into a thread, the bolt must be tightened using the Allen key.</p>	
<p>Ensure that the Allen key is of good quality and not worn.</p>	

3 Product Overview

3.1 Main parts of the wheelchair

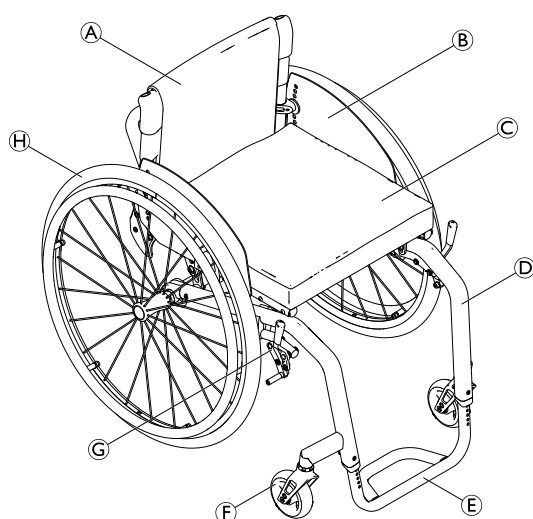

- Ⓐ Backrest
- Ⓑ Clothes-guard
- Ⓒ Seat with cushion
- Ⓓ Frame
- Ⓔ Footrest
- Ⓕ Castor fork with castor wheel
- Ⓖ Parking brake
- Ⓗ Rear wheel with handrim and quick-release axle

3.2 Dimensions

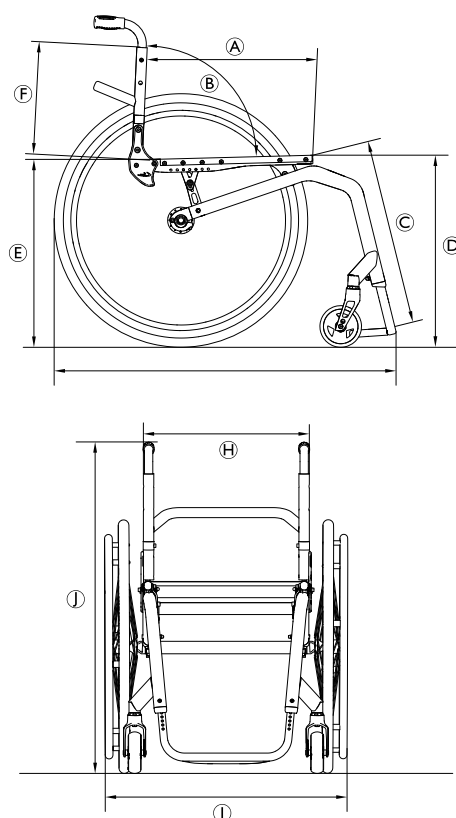

Ⓐ	Seat depth (SD)	350 – 525 mm, in increments of 25 mm
Ⓑ	Backrest angle (BA)	74°/78°/82°/86°/90°/94°
Ⓒ	Lower leg length (LLL)	290 – 480 mm, in increments of 10 mm
Ⓓ	Front seat-to-floor height (FSTF)	450 – 520 mm, in increments of 10 mm
Ⓔ	Rear seat-to-floor height (RSTF)	390 – 490 mm, in increments of 10 mm
Ⓕ	Backrest height (BH)	270 – 480 mm, in increments of 15 mm
Ⓖ	Total length (TL)	75° frame angle: approx. 830 mm 90° frame angle: approx. 760 mm
Ⓗ	Seat width (SW)	320 – 500 mm, in increments of 20 mm
Ⓘ	Total width (TW)	approx. 490 – 805 mm
	Total width, folded	
Ⓢ	Total height (TH)	approx. 650 – 1200 mm

4 Servicing

4.1 Inspection checklist

General inspection	☺	☹
Is the product in good condition and is it complete (product and optional equipment)?	<input type="checkbox"/>	<input type="checkbox"/>
Is the product free from damage or weaknesses of any kind?	<input type="checkbox"/>	<input type="checkbox"/>
Does the product operate correctly under nominal load?	<input type="checkbox"/>	<input type="checkbox"/>
Is the product fully functional in accordance with the user manual?	<input type="checkbox"/>	<input type="checkbox"/>
Eradication of faults	☺	☹
Have all the faults found been eliminated and have faulty components been replaced?	<input type="checkbox"/>	<input type="checkbox"/>
Are all screws/bolts firmly fitted and is the product securely assembled?	<input type="checkbox"/>	<input type="checkbox"/>
Completion of checks	☺	☹
Is the product technically and functionally safe?	<input type="checkbox"/>	<input type="checkbox"/>
Has the product been cleaned and disinfected?	<input type="checkbox"/>	<input type="checkbox"/>
Is the identification label easily readable and is it securely mounted on the product?	<input type="checkbox"/>	<input type="checkbox"/>
Is the product accompanied by the latest revision of the user manual?	<input type="checkbox"/>	<input type="checkbox"/>

4.2 Spare parts



WARNING!

Original spare parts must be used in all repairs. Otherwise the warranty and product declaration of conformity shall be rendered invalid.

All spare parts must be obtained from the Invacare customer service department. An electronic spare parts catalogue can be found on your local Invacare website.



WARNING!

Risk of injury due to damaged or worn parts

Some replacement parts are only available as a kit.
– Always use the complete new kit when replacing a part.

5 Reconditioning

5.1 Cleaning

IMPORTANT!

– The product does not tolerate cleaning in automatic washing plants, with high-pressure cleaning equipment or steam.

IMPORTANT!

Dirt, sand and seawater can damage the bearings and steel parts can rust if the surface is damaged.
 – Only expose the wheelchair to sand and seawater for short periods and clean it after every trip to the beach.
 – If the wheelchair is dirty, wipe off the dirt as soon as possible with a damp cloth and dry it carefully.

1. Remove any installed optional equipment (only optional equipment which does not require tools).
2. Wipe down the individual parts using a cloth or soft brush, ordinary household cleaning agents (pH = 6 - 8) and warm water.
3. Rinse the parts with warm water.
4. Thoroughly dry the parts with a dry cloth.



Car polish and soft wax can be used on painted metal surfaces to remove abrasions and restore gloss.

Cleaning upholstery

For cleaning upholstery refer to the instructions on the labels of the seat, cushion and backrest cover.

5.2 Disinfection



Information on recommended disinfectants and methods can be found on <https://vah-online.de/en/for-users>.

1. Wipe down all generally accessible surfaces with a soft cloth and ordinary household disinfectant.
2. Allow the product to air-dry.

5.3 Materials

The components used to manufacture Kuschall® wheelchairs consist of following materials:

Frame tubes	Aluminum
Backrest tubes	Aluminum / Titanium
Axle tube	Aluminum / Carbon Fiber
Seat cover / Backrest cover	PA / PE / PVC
Push handles	Aluminum / TPE
Clothes guard / Mudguard	Carbon Fiber or Plastic
Castor forks	Aluminum
Footrest tube	Aluminum / Titanium
Footplate	Carbon Fiber or Plastic
Supporting parts / Attachments	Steel / Aluminum
Screws and bolts	Steel

All components have either a protective coating or are corrosion resistant.

5.4 Reconditioning scheme

The following items must be reviewed and checked when reconditioning is required:

Symptoms	Faults	Solution
The wheelchair does not travel in a straight line	Incorrect tyre pressure on one rear wheel	Correct tyre pressure, see user manual
	One or more spokes broken	Replace broken spoke(s)
	Spokes tightened unevenly	Tighten loose spoke(s)
	Castor wheel bearings are dirty or damaged	Clean or replace the bearings or the complete castor wheel 6.6.1 <i>Replacing the castor wheel, page 32</i>
	Support bearings in forks faulty	Replace the support bearings, see 6.6.2 <i>Replacing the castor fork, page 33</i>
The wheelchair tips too easily	Rear wheels are mounted too far forwards	Mount the rear wheels further back, see 6.2.6 <i>Adjusting the tipping point, page 15</i>
	Backrest angle too large	Reduce backrest angle, see 6.3.3 <i>Backrest angle (BA), page 19</i>
	Seat angle too large	Adjust the front seat-to-floor height respectively the rear seat-to-floor height, see 6.2.3 <i>Seat angle (SA), page 13: Adjusting the front seat-to-floor height (FSTF), page 13 Adjusting the rear seat-to-floor height (RSTF), page 14.</i>
The parking brakes are gripping poorly or asymmetrically	Incorrect tyre pressure in one or both rear tyres	Correct tyre pressure, see user manual
	Brake setting incorrect	Correct brake setting, see 6.8.2 <i>Adjusting the parking brake, page 38</i>
The rolling resistance is very high	Incorrect tyre pressure in one or both rear wheels	Correct tyre pressure, see user manual
	Rear wheels not parallel	Make rear wheels parallel, see 6.7.1 <i>Ensuring the rear wheels are parallel, page 33</i>
	Bearings are dirty or faulty	Replace the bearings, see 6.6.1 <i>Replacing the castor wheel, page 32</i>
The castors wobble when moving fast	Too little tension on the clevis pin housing	Tighten the nut on the castor fork slightly, see 6.6.2 <i>Replacing the castor fork, page 33</i>
	Castor wheel is worn out	Replace the castor wheel, see 6.6.1 <i>Replacing the castor wheel, page 32</i>
The castor wheel is stiff or stuck	Bearings are dirty or faulty	Replace the bearings, see 6.6.1 <i>Replacing the castor wheel, page 32</i>
Increased forward tip tendency	Frame is deformed	Replace the frame, see 6.1 <i>Frame overview, page 12: Adjusting the front seat-to-floor height (FSTF), page 13 Adjusting the rear seat-to-floor height (RSTF), page 14.</i>

6 Instructions

6.1 Frame overview

The Küschall® K-Series frame is made from aluminum. Frame angles of 75° and 90° are existing. The frames are available in a standard version, a tapered version and a plus 50 mm version.

Frame	Front seat-to-floor height (FSTF) [mm] ¹⁾	Lower leg length (LLL) with standard-mounted footrest bar [mm]	Lower leg length (LLL) with standard-mounted fold-up footrest [mm]	Seat depth [mm]
75° short	450 to 470	FSTF -120 ²⁾ to FSTF -30	FSTF -160 ²⁾ to FSTF -30	350 to 450
75° standard	480 to 500	FSTF -110 ²⁾ to FSTF -30	FSTF -150 ²⁾ to FSTF -30	350 to 450
75° + 50 mm	500 to 520	FSTF -110 ²⁾ to FSTF -30	FSTF -150 ²⁾ to FSTF -30	425 to 525
90° short	450 to 470	FSTF -140 ²⁾ to FSTF -40	FSTF -180 ²⁾ to FSTF -40	350 to 450
90° standard	480 to 500	FSTF -130 ²⁾ to FSTF -40	FSTF -170 ²⁾ to FSTF -40	350 to 450
90° + 50 mm	500 to 520	FSTF -130 ²⁾ to FSTF -40	FSTF -170 ²⁾ to FSTF -40	425 to 525
75° tapered	480 to 500	FSTF -110 ²⁾ to FSTF -30	FSTF -150 ²⁾ to FSTF -30	350 to 450
90° tapered	480 to 500	FSTF -130 ²⁾ to FSTF -40	FSTF -170 ²⁾ to FSTF -40	350 to 450

¹⁾ Measured with a 24" rear wheel. Using a 25" rear wheel the FSTF is 10 mm greater in each case. Using a 26" rear wheel the FSTF is 20 mm greater in each case.

²⁾ Measured with a 24" rear wheel. Using a 25" rear wheel the FSTF is 10 mm smaller in each case. Using a 26" rear wheel the FSTF is 20 mm smaller in each case.

Examples:

Frame	Rear wheel	FSTF [mm]	LLL [mm] with standard-mounted bar	LLL [mm] with standard-mounted fold-up footrest
75° short	25"	460 to 480	FSTF -130 to FSTF -30	FSTF -170 to FSTF -30
75° short	26"	470 to 490	FSTF -140 to FSTF -30	FSTF -180 to FSTF -30

For lower leg lengths, the high-mounted footrest must be used, see chapter 6.4.5 *Replacing the high-mounted footrest*, page 24.

6.2 Seat

6.2.1 Seat width (SW)

Available seat widths: SW 320 to 500 in 20 mm steps.

Changing the seat width is very complicated and requires the replacement of numerous parts.

6.2.2 Seat depth (SD)

Available seat depths: SD 350 to 525 in 25 mm steps.

Changing the seat depth requires the replacement of the complete seat module including the seat cover and the seat rail and potentially also the seat cushion.

6.2.3 Seat angle (SA)

The seat angle is determined by the difference between the rear seat-to-floor height (RSTF) and the front seat-to-floor height (FSTF).

6.2.4 Front seat-to-floor height (FSTF)

Adjusting the front seat-to-floor height (FSTF)

Reposition or replace the brackets at the front frame to adjust the front seat-to-floor height.



Allen key (4 mm, 5 mm) / Socket spanner (10 mm)



1. Remove the rear wheels, fold the backrest forward and place the wheelchair on its back.
2. Remove the screws **A** and **B** that connect the seat brace **C** to the seat module or the frame on both sides.
3. Remove the screw **E** and place it in the bracket's **D** other hole. If you require a new bracket, remove the screws **E**, **F** and **H**, replace the bracket **D** and fix it to the seat module and cross brace **G** using the screws **E**, **F** and **H**.
4. Reinstall the rear wheels, fold up the backrest and check the position of the seat braces **C**.
5. Tighten the screw connections **A** and **B** of the seat braces and **E** and **F** of the front brackets again.
6. Carry out the same setting on both sides.



Consider that adjusting the front seat-to-floor height (FSTF) results in a change to the seat angle. It may be necessary to correspondingly adjust the rear seat-to-floor height (RSTF) or the backrest angle.

- A** = 7 Nm (high strength)
- B** = 13 Nm (high strength)
- E** = 7 Nm (high strength)
- F** = 7 Nm (Tuflok®)
- H** = 13 Nm (high strength)

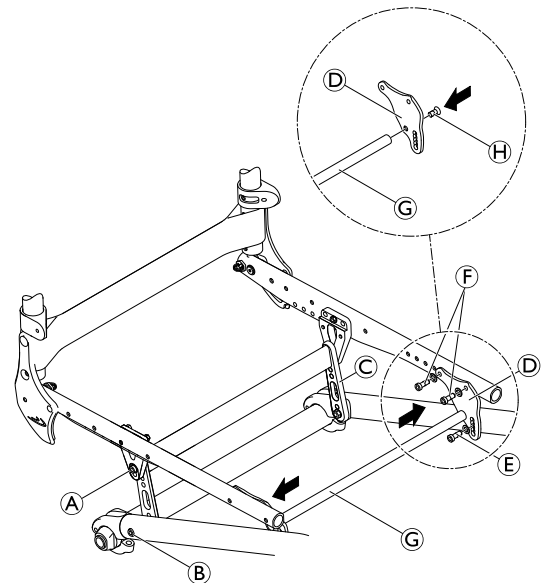

6.2.5 Rear seat-to-floor height (RSTF)

The seat braces can be repositioned to adjust the rear seat-to-floor height. They are available in three different sizes, covering seat heights of between 380 and 500 mm.

Generally, it is recommended to use the lower hole to install the seat braces on the frame.

Rear seat height based on wheel position and wheel size

RSTF [mm]	24" wheel			25" wheel			26" wheel		
	S	M	L	S	M	L	S	M	L
380	1	—	—	—	—	—	—	—	—
390	1	—	—	1	—	—	—	—	—
400	2	—	—	1	—	—	1	—	—
410	3	5a	—	2	—	—	1	—	—
420	4	5	—	3	5a	—	2	—	—
430	—	6	—	4	5	—	3	5a	—
440	—	7	9a	—	6	—	4	5	—
450	—	8	9	—	7	9a	—	6	—
460	—	—	10	—	8	9	—	7	9a
470	—	—	11	—	—	10	—	8	9
480	—	—	12	—	—	11	—	—	10
490	—	—	—	—	—	12	—	—	11
500	—	—	—	—	—	—	—	—	12

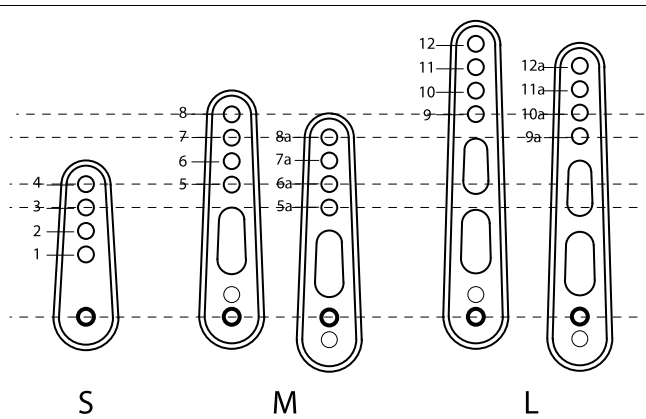

Adjusting the rear seat-to-floor height (RSTF)

Reposition or replace the seat braces at the rear frame to adjust the rear seat-to-floor height.



Allen key (5 mm) / Socket spanner (10 mm)



1. Remove the rear wheels, fold the backrest forward and place the wheelchair on its back.
2. Loosen the screws **A** for the front bracket on both sides.
3. If you can set the desired seat height using the existing seat brace **B**, loosen the screw **C** and remove screw and washer **D** and the connecting bar **E**.
4. If you require a new seat brace, remove the existing one and the connecting bar **E** and loosely fix the new seat brace with spacer **F**, washer and nut to the frame using screw **C**.
5. Slide the seat brace against the rear bracket **G** so that the required holes overlap.
6. Insert the connecting bar **E** and fix it with screw **D**.
7. Carry out the same setting on both sides.
8. Reinstall the rear wheels, fold up the backrest and check the position of the seat brace **B**.
9. Tighten the screws **A**, **C** and **D**.

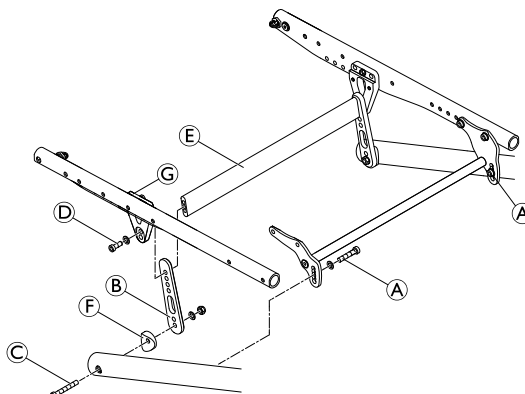

Consider that adjusting the rear seat-to-floor height (RSTF) results in a change to the seat angle. It may be necessary to correspondingly adjust the front seat-to-floor height (FSTF) or the backrest angle.

- A** = 7 Nm (high strength)
- C** = 13 Nm (high strength)
- D** = 7 Nm (high strength)

6.2.6 Adjusting the tipping point



Allen key (4 mm, 5 mm) / Socket spanner (8 mm)



1. Remove the rear wheels, fold the backrest forward and place the wheelchair on its back.
2. Remove the bolts (A), (B) and (E).
3. Remove the bolts (C), (D) and (F) and slide the seat module forwards or backwards.

 If necessary the insert (I) has to be shifted inside the seat module tube. Remove bolt (H) for fastening the seat cover, shift insert (I) and re-insert bolt (H) and tighten.

 The round nut (J) is positioned in the frame tube with a grub screw which presses against the inner wall of the tube. To reposition the round nut, loosen the grub screw using an Allen key through the frame hole and the thread of the round nut.

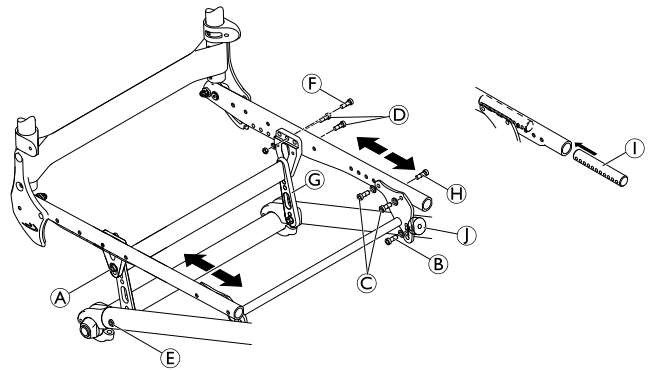

4. Insert bolts (A), (B) and (E) and tighten.
5. Carry out the same setting on both sides.

There are 5 possible positions for the rear bracket and 5 possible positions for the front bracket.

 Make sure to move the rear bracket and the front bracket to the same number of holes.

- (A) = 7 Nm (high strength)
- (B) = 7 Nm (high strength)
- (C) = 7 Nm (Tuflok®)
- (D) = 7 Nm (high strength)
- (E) = 13 Nm (high strength)
- (F) = 7 Nm

6.2.7 Installing a suspension

A suspension can be fitted for a rear seat-to-floor height (RSTF) of between 380 mm and 460 mm. The use of a seat module with the welded cross brace is required when installing the suspension.



Allen key (4 mm, 5 mm) / Lubricant



1. Remove the rear wheels, fold the backrest forward and place the wheelchair on its back.
2. Remove the seat module by removing the front bracket **A** and the rear bracket **B** on both sides.
3. Remove the seat brace **C**.
4. Fit the suspension housing **D** to the frame. Here, slide the screw with the washer **E** through the suspension housing and place the lubricated sleeve with the spacer elements on the screw. Slide the screw through the frame into the axle holder stay and tighten firmly with spacer and nut.

Function check:

It must be possible to rotate the suspension housing **D**, but it must not be loose.

5. Insert the suspension seat strut **F** from above into the suspension housing **D**. Slide the sleeve **G** from below over the suspension seat strut and position it at the required seat height. Secure with screw and washer **H**. Carry out the same setting on both sides.
6. Lubricate the springs **I** and insert them into the suspension housings.
7. Insert the screws **J** into the suspension housings until they protrude by 25 mm.
8. Mount the front and rear spring brackets to the seat module using screws **K**.
9. Insert the lubricated rotating sleeves **L** and fix the seat module to the frame using screws **M**.
10. Reinstall the rear wheels.

Final check:

Check the front seat-to-floor height (FSTF). When fitting the mudguard, ensure that it is at least 40 mm from the wheel. Check the suspension function.

E = 7 Nm

H = 4 Nm

K = 7 Nm

M = 7 Nm

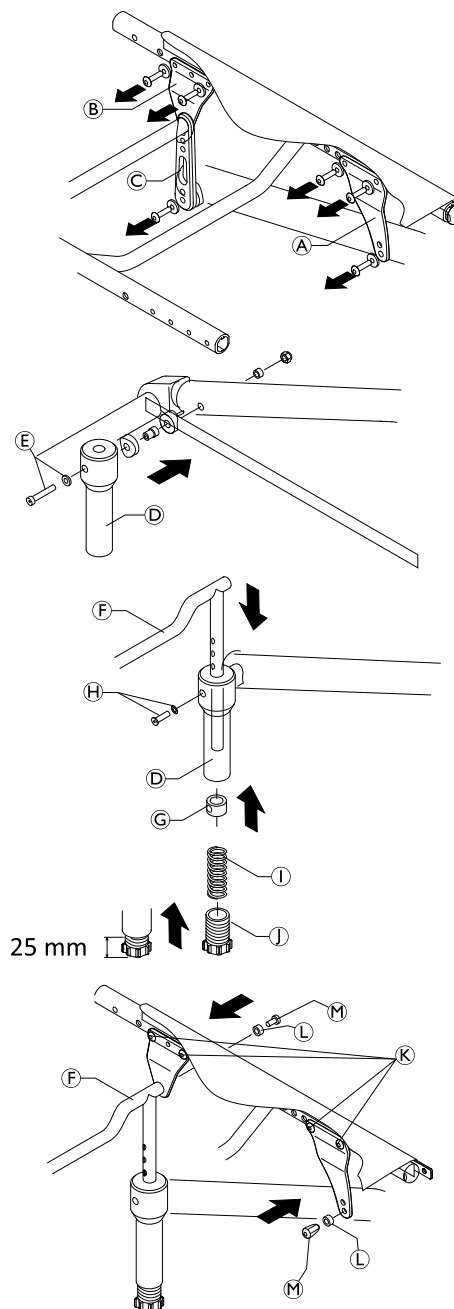

6.3 Backrest

6.3.1 Tension adjustable backrest

The adjustable back is fitted with hook and loop bands and a cover. Apart from the adjustable back there is the light cover, which is produced individually for each backrest height (BH) and seat width (SW).

Possible backrest heights (BH) in relation to cover, backrest tube, push handles and bands

BH [mm]	Cover size	Backrest tube size ①	Standard push handles ① / Foldable push handles (telescopic tube straight ②)		
			Size ① or ②	Bands above stabilizing bar	Top band ③
270*	S	S	S	1-band ④	③ = 5 cm
285	S	S	S	1-band ④	
300	S	S	S	1-band ④	
315	S	L	S	1-band ④	③ = 10 cm
330	S	L	S	1-band ④	
345	M	L	S	2 x 1-band ④	
360	M	L	S	2 x 1-band ④	
375	M	L	S	2 x 1-band ④	
390	M	L	L	2-bands + 1-band	
405	M	L	L	2-bands + 1-band	
420	L	L	L	2-bands + 1-band	
435	L	L	L	2-bands + 1-band	
450	L	L	L	2 x 2-bands ⑤	
465	L	L	L	2 x 2-bands ⑤	
480	L	L	L	2 x 2-bands ⑤	

* BH 270 mm is only possible with standard push handles

Possible backrest heights (BH) to push handles, telescopic tubes and bands

BH [mm]	Without push handles ©		Height-adjustable push handles rear-set ④		
	Bands above stabilizing bar	Top band ⑥	Telescopic tube bended ©	Bands above stabilizing bar	Top band ⑥
270	1-band ⑥	⑥ = 5 cm	—	—	—
285	1-band ⑥		S	1-band ⑥	⑥ = 5 cm
300	1-band ⑥		S	1-band ⑥	
315	1-band ⑥		S	1-band ⑥	
330	1-band ⑥		S	1-band ⑥	
345	1-band ⑥	S	1-band ⑥		
360	2 x 1-band ⑥	⑥ = 10 cm	S	1-band ⑥	⑥ = 10 cm
375	2 x 1-band ⑥		M	1-band ⑥	
390	2 x 1-band ⑥		M	2 x 1-band ⑥	
405	2-bands + 1-band		M	2 x 1-band ⑥	
420	2-bands + 1-band		M	2 x 1-band ⑥	
435	2-bands + 1-band		L	2-bands + 1-band	
450	2-bands + 1-band		L	2-bands + 1-band	
465	2 x 2-band ⑥		L	2-bands + 1-band	
480	2 x 2-band ⑥		L	2-bands + 1-band	

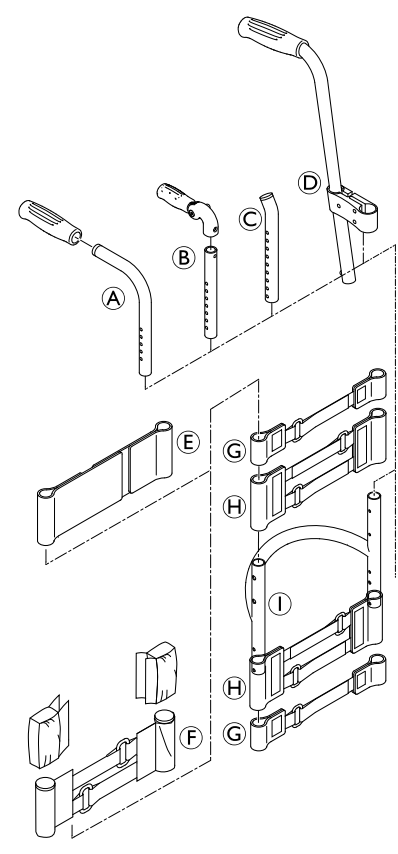

A 1-band is installed beneath the stabilizing bar if there is a clothes-guard, and a 2-bands if there is a mudguard.

6.3.2 Backrest height (BH)

The backrest height (BH) can be changed by mounting the telescopic tubes into another position in the backrest tubes. If this setting option is insufficient, the telescopic tubes can be replaced.

Adjusting the backrest height

Allen key (3 mm) / Wrench (8 mm)



1. Remove the backrest cover ①.
2. Remove the screw connection ②.
3. Adjust the backrest tube ③ to the required height then insert the screw ② into the closest hole and retighten.
4. Carry out the same setting on both sides.
5. Reposition the backrest cover correctly.

② = 7 Nm



If the required height cannot be achieved, install a different telescopic tube or push handle.

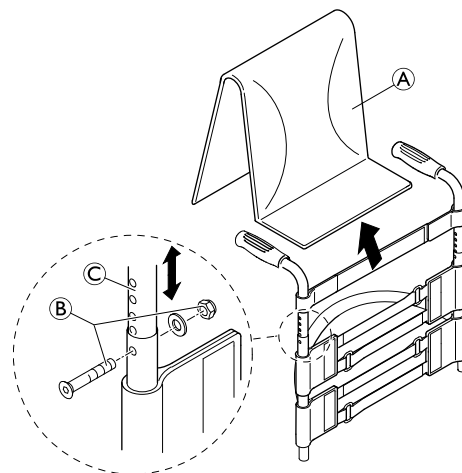

6.3.3 Backrest angle (BA)

The angle of the backrest can be changed by repositioning the excenter plate in the backrest joint plate. The following angles (measured from the seat) can be set:

74°	78°	82°	86°	90°

Adjusting the backrest angle



Allen key (3 mm) / Wrench (10 mm)



1. Fold down the backrest and release the counter nut of the adjustment screw **A** and screw it in completely.
2. Remove the screw **B** on the excenter plate **C**. Remove the excenter plate and reinsert it in the required position. The excenter plates must be positioned identically on both sides in the backrest joint.
3. Reinsert the screw **B** and tighten it.
4. Adjust the backrest joint, see below.
5. Fold up the backrest and let the pin **A** engage.
6. Press the backrest forwards to ensure the joint cannot move.
7. Unscrew the screw **F** until it touches the seat frame **G**.
8. Screw the screw back in by between a ¼ and a ½ turn and counter with the counter nut **E**.
9. Make sure that the backrest joint is adjusted correctly on both sides.

- B** = 4 Nm
- E** = 7 Nm

Function control:

Sit in the wheelchair and lean back so that the backrest is strained. Upon pulling the release cord **H**, the pin **D** must be easily removed on both sides and must fully glide back in upon letting go of the release cord.

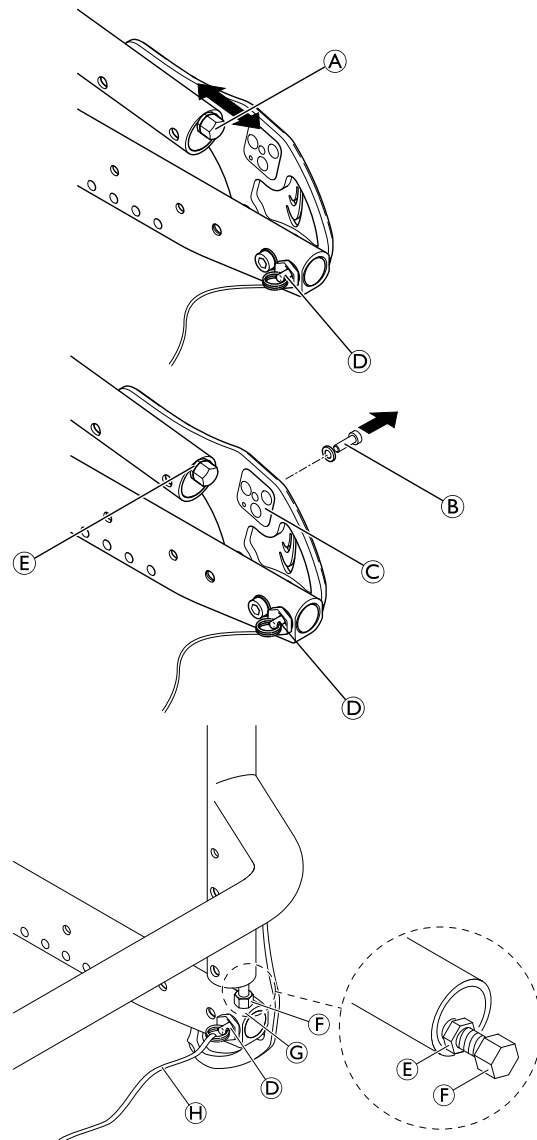

6.3.4 Installing/adjusting the release cord

**WARNING!**

Risk of injury to the user during use as a result of the backrest folding over unintentionally.

If the release cord is too taut, the locking mechanism (B) can open unintentionally.

– Make sure that the release cord is not too taut.

1. Knot the release cord (A) on the left and right side to the wire rings (C) such that it is free from tension, but still ensuring that there is only minimal slack (< 5 mm).

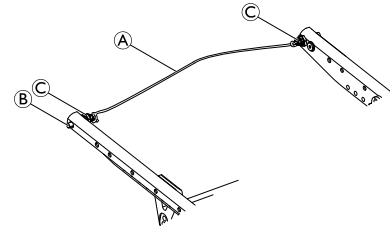

6.3.5 Replacing the backrest tube



Allen key (3 mm, 4 mm) / Socket spanner (8 mm, 10 mm)



1. Remove the backrest cover.
2. Slide the backrest bands upwards or downwards to gain access to the screws **(A)**. Remove the screws and nuts on both sides.
3. Remove the push handles or the telescopic tubes and the upper hook and loop bands.
4. Remove the screws **(B)** on the backrest joint.
5. Remove the lower hook and loop bands and the sleeve **(D)** with the adjustment screw **(E)** from the backrest tube **(C)** and install both to the new backrest tube.
6. Install the backrest tube to the backrest joint with the screws **(B)**. Here, first install the lower screw followed by the upper one.
7. Install the upper hook and loop bands and the push handles respectively the telescopic tubes again using screws and nuts **(A)**.
8. Carry out the same setting on both sides.
9. Reposition the backrest cover.

(A) = 7 Nm

(B) = 7 Nm

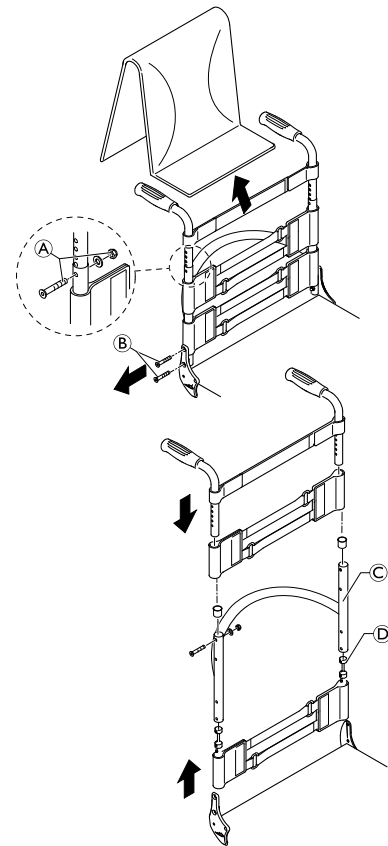

Check:

Check the settings of the adjustment screws **(E)** on both sides. The screw head must only lightly touch the seat module when the backrest is in upright position. If necessary, readjust the length by releasing the counter nut and tightening or loosening the adjustment screw. Then retighten the counter nut **(F)**.

IMPORTANT!

Incorrectly adjusted adjustment screws result in damage to the backrest joint mechanism.

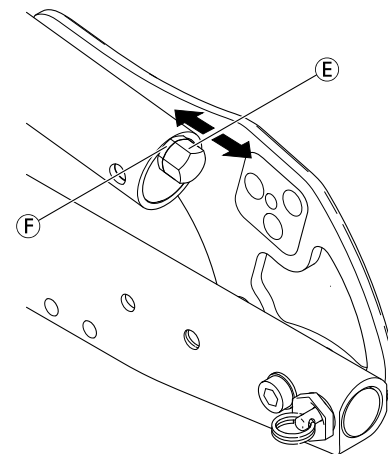

6.3.6 Replacing the handle

An adhesive (e.g. hair spray) is used in these instructions. When applied to the handle, this substance works as a lubricant and as an adhesive once dry.



CAUTION!

Risk of accidents due to the handle comes loose

– After drying, the adhesive used must be able to resist a pull-off force of 750 N. If in doubt, contact Invacare.



1. Remove the old handle.
2. Remove any residue (residual adhesive, grease, dust) from the push handle tube.
3. Apply a thin layer of hair spray all over the surface of the push handle tube onto which the handle is to be slid.
4. Apply a thin layer of hair spray to the inside of the handle.
5. Slide the new handle onto the push handle tube.
6. Move the handle into the correct position (grooves facing upwards).

If a long handle has been fitted and this is to be replaced with a short one, the push handle tube must be shortened by 35 mm.

The push handle tube must be replaced when switching from a short to a long handle.

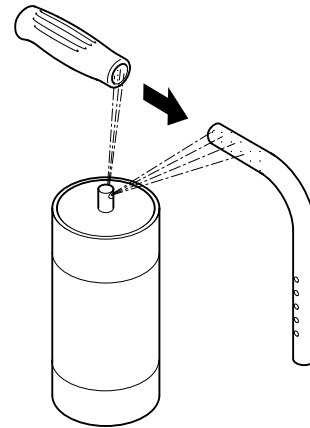

6.3.7 Replacing the foldable Push Handle



Hole punch pliers (6 mm) / Allen key (3 mm, 4 mm)



1. Remove the old foldable push handle.
2. Pull down the backrest cover (F) on the telescopic tube, until its hole (B) is uncovered.

IMPORTANT!

– Make sure that the threaded insert (E) (part no. 1580450) supplied with the new push handle is used for assembly.

3. Place the threaded insert (E) in the telescopic tube.
4. Punch a hole through the backrest cover with a distance of 10 mm from the upper edge, using hole punch pliers (see graphic below).
5. Slide the new foldable push handle (A) onto the telescopic tube.
6. Pull up the backrest cover, until it covers completely the rear hole in the push handle.
7. Install the foldable push handle with screw (C) and washer (G).
8. Check screws (D) on both sides of the push handle and retighten if necessary.
9. Carry out the same steps for the other push handle.

IMPORTANT!

– Make sure that the folding force is approximately 5 N (0.5 kg).

IMPORTANT!

– Fixing screw (C) may only be used once. Alternatively the screw can be cleaned (remove old thread locking adhesive) and reinstalled with new low-strength thread locking adhesive.

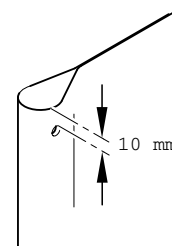
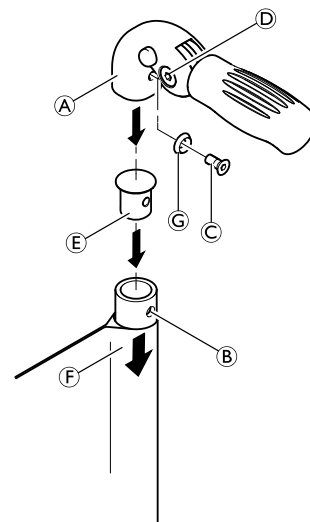

The retrofit of foldable push handles requires new tubing.

6.4 Footrests

The footrest must be selected in accordance with the seat width. Standard footrests and angle-adjustable footrests are available. Furthermore, there is a choice between a high-mounted footrest and a fold-up footrest.

Lower leg length (LLL)

To change the lower leg length, the footrest can be installed in a higher or lower position, see *6.4.2 Adjusting the footrest height, page 23*. Also refer to the table in chapter *6.1 Frame overview, page 12*. The shortest lower leg lengths can be achieved using a high-mounted footrest, see *6.4.5 Replacing the high-mounted footrest, page 24*.

6.4.1 Replacing the footrest



Allen key (4 mm) / Socket spanner (8 mm)



1. Remove the bolts, washers and nuts (A) on both sides.
2. Remove the footrest.
3. Insert the new footrest into the frame tubes and move it to the required height.
4. Reinsert bolts, washers and nuts on both sides and tighten.

(A) = 7 Nm

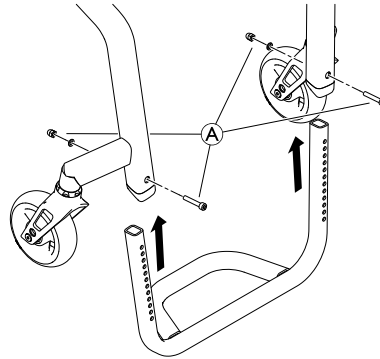

6.4.2 Adjusting the footrest height

The height of the footrest can be adjusted in steps of 10 mm.



Allen key (4 mm) / Socket spanner (8 mm)



1. Remove the bolts, washers and nuts (A) on both sides.
2. Move the footrest to the required height.
3. Reinsert bolts, washers and nuts on both sides and tighten.

(A) = 7 Nm



If the required lower leg length cannot be achieved, a high-mounted footrest must be installed, see chapter *6.4.5 Replacing the high-mounted footrest, page 24*.

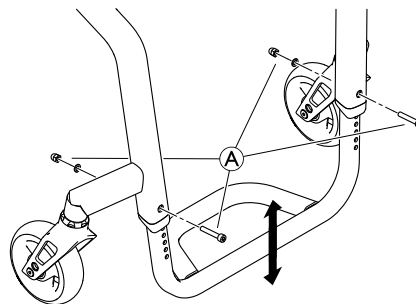

6.4.3 Installing/replacing the foot plate



Allen key (3 mm) / Screw clamps / Drill, drill bit (7 mm)



1. Position and fasten the foot plate (A) cleanly to the footrest (B) using screw clamps.
2. Center punch the footrest through the holes on the foot plate.
3. Remove the screw clamps and the foot plate.
4. Drill completely through the footrest at the punched points.
5. Insert blind rivet nuts (D) into the four holes from above.
6. Position the foot plate again on the footrest and fasten with bolts (C).

(C) = 4 Nm

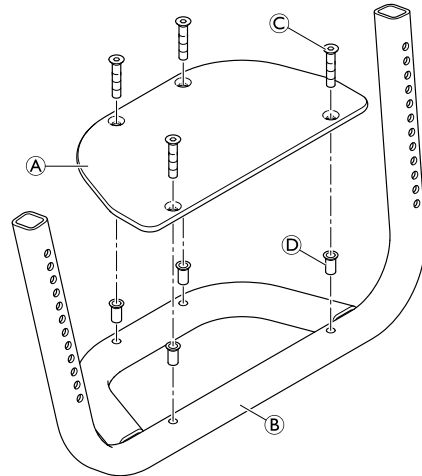

6.4.4 Replacing the angle-adjustable footrest



Allen key (4 mm) / Socket spanner (8 mm)



1. Remove bolts (G) from the frame tubes (H).
2. Remove the footrest assembly (A) and (B) with the foot plate (C) from the frame.
3. Remove all bolts (D), washers (E) and nuts (F) from the foot plate (C).
4. Remove the foot plate.
5. Remove the telescopic footrest tubes (A) from the clamping part (B), if necessary.
6. Install a new angle-adjustable footrest by reversing steps 4 – 1.

(F) = 13 Nm

(G) = 7 Nm

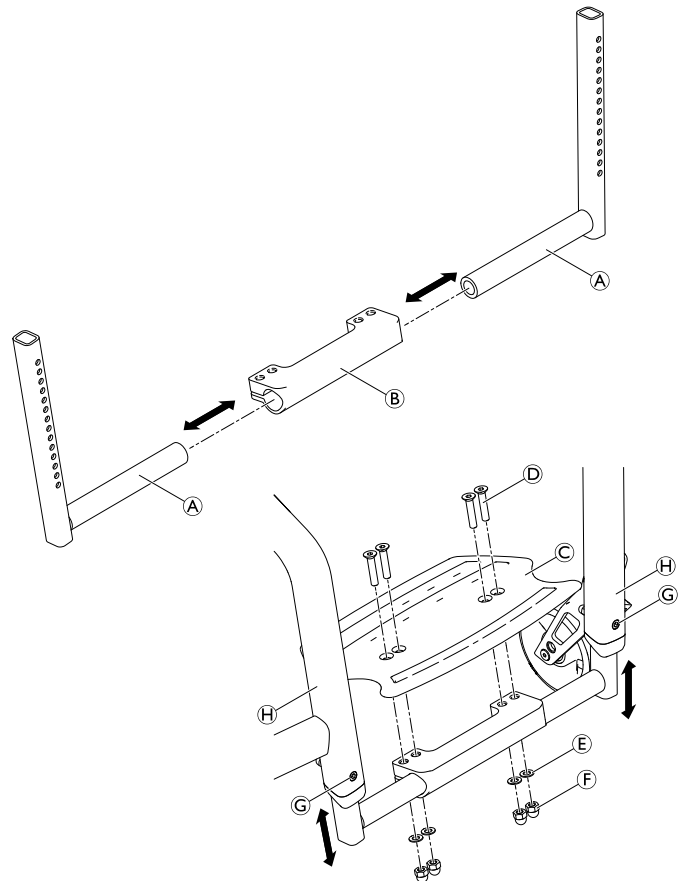

6.4.5 Replacing the high-mounted footrest



Allen key (4 mm) / Socket spanner (8 mm)



1. Remove the high-mounted footrest **A** by removing bolts **B**, washers **C** and clamping parts **D**.
2. Install the high-mounted footrest by reversing step 1.

B = 7 Nm

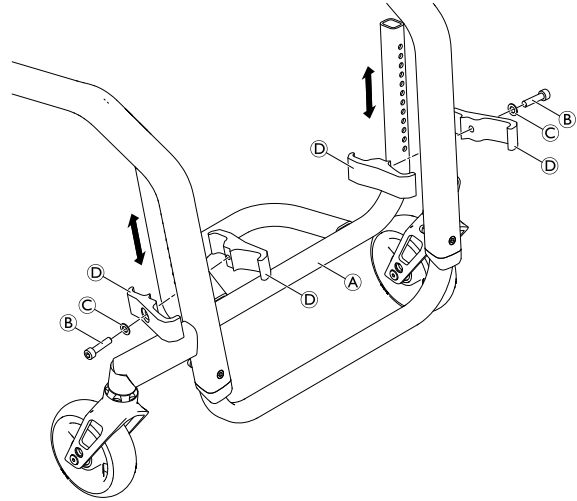

6.4.6 Installing the flip-up footrest



Allen key (4 mm) / Socket spanner (8 mm)



1. Slide the footrest tubes **A** and **E** into the clamping part **F**.
2. Install the foot plate **J** using bolts **K**, washers **L** and nuts **M**.
3. Install the telescopic tube **B** with washers **C** to the footrest tube **A** using bolt **D**.
4. Install the sleeve **G** to the telescopic tube **H** using bolt **I**.

D = 4 Nm
I = 7 Nm
M = 13 Nm

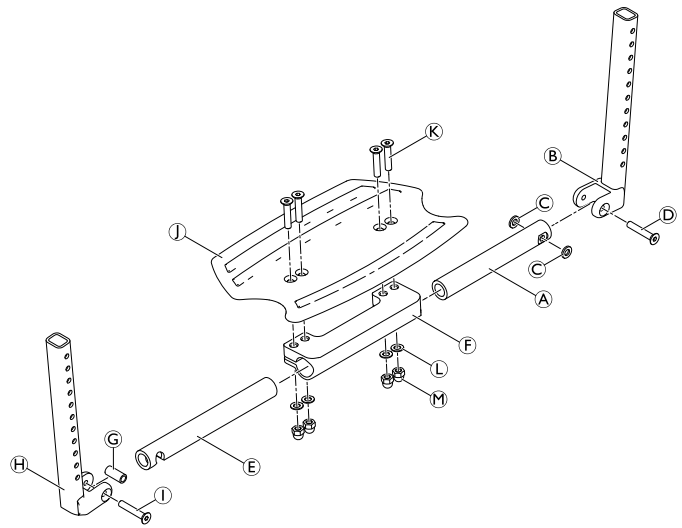

1. Remove bolts **A**, washers **B** and nuts **C** and remove the existing footrest.
2. Slide the telescopic tube assembly **D** into the left frame tube **F** to the required height and secure with bolts, washers and nuts through the nearest hole.
3. Slide the telescopic tube assembly **E** into the right frame tube to the same height and secure with bolts, washers and nuts through the nearest hole.
4. Install the footrest stabilisation bar **G**, with brackets **H** and bolts **I** to the frame tubes **F**.

A = 7 Nm
I = 7 Nm

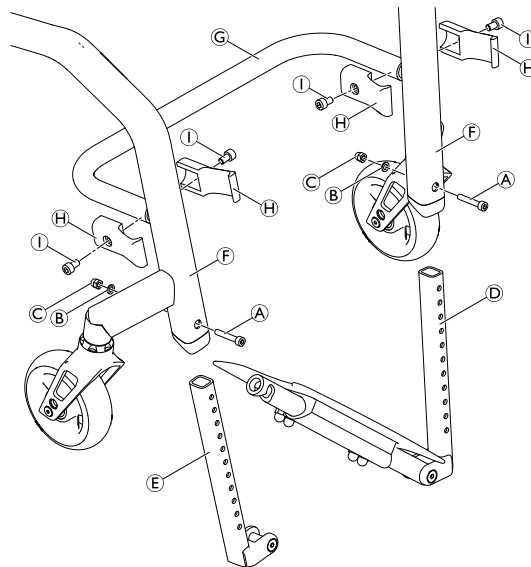

6.5 Sideparts

6.5.1 Clothes-guard / Mudguard

The clothes-guard fitted as standard can be replaced by a mudguard. Clothes-guard and mudguard are available in plastic or in carbon. For the carbon mudguard there is an additional size (XL) for the two smallest rear seat-to-floor heights (RSTF).

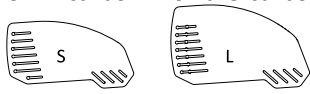

Plastic clothes-guard sizes according to rear wheel size and position

RSTF [mm]	24" Rear wheel					25" Rear wheel					26" Rear wheel				
	Position					Position					Position				
	1	2	3	4	5	1	2	3	4	5	1	2	3	4	5
380	L	L	L	L	L	—	—	—	—	—	—	—	—	—	—
390	L	L	L	L	L	L	L	L	L	L	—	—	—	—	—
400	L	L	L	L	L	L	L	L	L	L	L	L	L	L	L
410	L	L	L	S	S	L	L	L	L	L	L	L	L	L	L
420	L	S	S	S	S	L	L	L	L	L	L	L	L	L	L
430	S	S	S	S	S	L	L	L	S	S	L	L	L	L	L
440	S	S	S	S	S	L	S	S	S	S	L	L	L	L	L
450	S	S	S	S	S	S	S	S	S	S	L	L	L	S	S
460	S	S	S	S	S	S	S	S	S	S	L	S	S	S	S
470	S	S	S	S	S	S	S	S	S	S	S	S	S	S	S
480	S	S	S	S	S	S	S	S	S	S	S	S	S	S	S
490	—	—	—	—	—	S	S	S	S	S	S	S	S	S	S
500	—	—	—	—	—	—	—	—	—	—	S	S	S	S	S

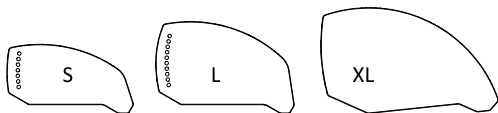

Carbon clothes-guard sizes according to rear wheel size and position

RSTF [mm]	24" Rear wheel					25" Rear wheel					26" Rear wheel				
	Position					Position					Position				
	1	2	3	4	5	1	2	3	4	5	1	2	3	4	5
380	XL	L	L	L	L	—	—	—	—	—	—	—	—	—	—
390	L	L	L	L	L	XL	XL	XL	L	L	—	—	—	—	—
400	L	L	L	L	L	XL	L	L	L	L	XL	XL	XL	XL	XL
410	L	L	L	L	L	L	L	L	L	L	XL	XL	XL	XL	XL
420	L	L	L	L	L	L	L	L	L	L	XL	XL	XL	L	L
430	L	L	L	L	L	L	L	L	L	L	XL	L	L	L	L
440	L	L	L	S	S	L	L	L	L	L	L	L	L	L	L
450	L	S	S	S	S	L	L	L	S	S	L	L	L	L	L
460	S	S	S	S	S	L	S	S	S	S	L	L	L	L	L
470	S	S	S	S	S	S	S	S	S	S	L	L	L	L	L
480	S	S	S	S	S	S	S	S	S	S	L	L	L	L	L
490	—	—	—	—	—	S	S	S	S	S	L	L	L	S	S
500	—	—	—	—	—	—	—	—	—	—	L	S	S	S	S

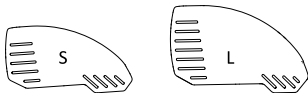

Plastic removable mudguard sizes according to rear wheel size and position

	24" Rear wheel					25" Rear wheel					26" Rear wheel				
	Position					Position					Position				
RSTF [mm]	1	2	3	4	5	1	2	3	4	5	1	2	3	4	5
380	L	L	L	L	L	—	—	—	—	—	—	—	—	—	—
390	L	L	L	L	L	L	L	L	L	L	—	—	—	—	—
400	L	L	S	S	S	L	L	L	L	L	L	L	L	L	L
410	S	S	S	S	S	L	L	L	L	L	L	L	L	L	L
420	L	S	S	S	S	L	L	S	S	S	L	L	L	L	L
430	S	S	S	S	S	S	S	S	S	S	L	L	L	L	L
440	S	S	S	S	S	L	S	S	S	S	L	L	S	S	S
450	S	S	S	S	S	S	S	S	S	S	S	S	S	S	S
460	S	S	S	S	S	S	S	S	S	S	L	S	S	S	S
470	S	S	S	S	S	S	S	S	S	S	S	S	S	S	S
480	S	S	S	S	S	S	S	S	S	S	S	S	S	S	S
490	—	—	—	—	—	S	S	S	S	S	S	S	S	S	S
500	—	—	—	—	—	—	—	—	—	—	S	S	S	S	S

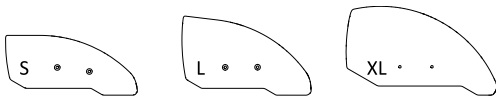

Carbon mudguard sizes according to rear wheel size and position

	24" Rear wheel					25" Rear wheel					26" Rear wheel				
	Position					Position					Position				
RSTF [mm]	1	2	3	4	5	1	2	3	4	5	1	2	3	4	5
380	XL	XL	XL	L	L	—	—	—	—	—	—	—	—	—	—
390	XL	L	L	L	L	XL	XL	XL	XL	XL	—	—	—	—	—
400	L	L	L	L	L	XL	XL	XL	XL	XL	XL	XL	XL	XL	XL
410	L	L	L	L	L	XL	XL	XL	L	L	XL	XL	XL	XL	XL
420	L	L	L	L	L	XL	L	L	L	L	XL	XL	XL	XL	XL
430	L	L	L	S	S	L	L	L	L	L	XL	XL	XL	XL	XL
440	L	S	S	S	S	L	L	L	L	L	XL	XL	XL	L	L
450	S	S	S	S	S	L	L	L	S	S	XL	L	L	L	L
460	S	S	S	S	S	L	S	S	S	S	L	L	L	L	L
470	S	S	S	S	S	S	S	S	S	S	L	L	L	L	L
480	S	S	S	S	S	S	S	S	S	S	L	L	L	L	L
490	—	—	—	—	—	S	S	S	S	S	L	L	L	S	S
500	—	—	—	—	—	—	—	—	—	—	L	S	S	S	S

Replacing the clothes-guard



Allen key (3 mm, 4 mm)



1. If present, remove the clothes-guard to be replaced by loosening the screw connection ③.
2. Install the mounting element ① with parts ⑥, ⑤, ④ on the backrest tube ⑦.
3. Check the correct position of the clothes-guard ② with fitted rear wheel. Here, find the suitable height on the clothes-guard for fixing the screw connection ③ to the backrest mounting element ①.
4. Gently tighten screw connection ③ until it slightly jams.
5. Secure with grub screw ⑧.
6. If necessary, the holder ⑩ on the seat module can be replaced by removing/installing screw ⑪, washer ⑫ and cap nut ⑬.



The clothes-guard is correctly positioned if it can be inserted between the seat module and the holder and the upper edge runs above the rear wheel.

⑥ = 4 Nm

⑧ = 4 Nm

⑬ = 7 Nm

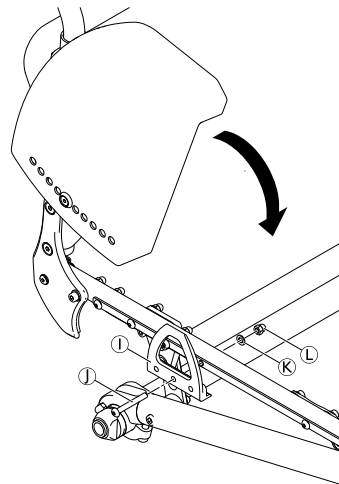
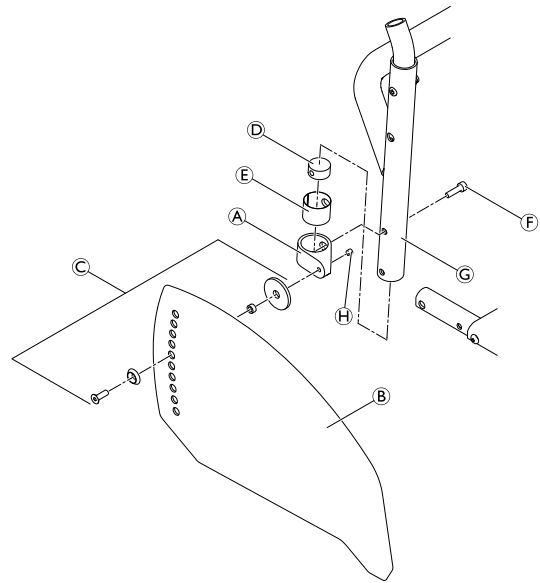

Installing the mudguard



Allen key (3 mm, 4 mm) / Socket spanner (10 mm) / Phillips screwdriver (2 mm)



1. Remove the clothes-guard and the mounting elements on the backrest and the seat.
2. Install the holder (B) to the seat module using the screw connections (A) and plate (C) and then refit the rear wheel.
3. Slightly loosen the grub screw (D) on the adjustment plate (E) and slide it along the mudguard carrier until the mudguard is at the required height.
4. The position of the mudguard can also be adjusted: Here, loosen the screw connections (F), position the mudguard as required and retighten the screw connections.
5. Tighten the grub screw (D) again.
6. Carry out the same setting on both sides.
7. Tighten or loosen the screws (G) to adjust how easy the mudguard can be moved out or into the holder.

(A) = 7 Nm

(D) = 4 Nm

(F) = 7 Nm



The existing axle may not be sufficiently long for the new configuration with mudguard. In this case, a longer axle must be installed. See chapter 6.7.4 *add link to chapter, page 34*.

Risk of pinching your fingers

- The distance between the mudguard and the wheel must be either < 8 mm or > 25 mm to prevent fingers from becoming caught between the wheel and the mudguard.



CAUTION!

Risk of pinching your fingers

- The distance between the mudguard and the wheel must be either < 8 mm or > 25 mm to prevent fingers from becoming caught between the wheel and the mudguard.

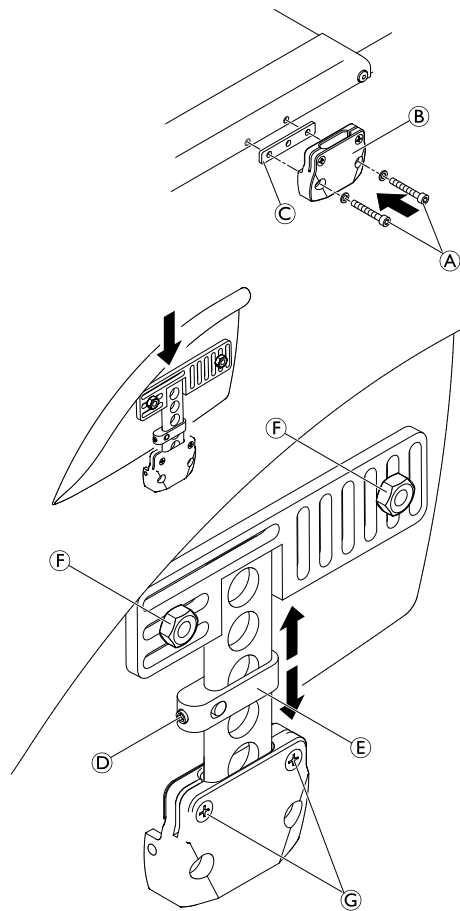

6.5.2 Installing the tubular armrest



WARNING!

Risk of injuries due to incorrect installation

If the tubular armrest option is to be installed, the seat module must be cut off depending on the configuration of the wheelchair.

– The tubular armrest must only be installed by Invacare shop assembly. Therefore, contact Invacare customer service.

Adjusting the height



Allen key (4 mm) / Socket spanner (8 mm)



1. Remove bolt, washer and nut ②.
2. Reposition the round nut ① in the armrest tube.
3. Reinsert the bolt into the round nut through the appropriate hole in the tube and tighten with washer and nut ②.
4. Place the armrest in the holder.

② = 7 Nm

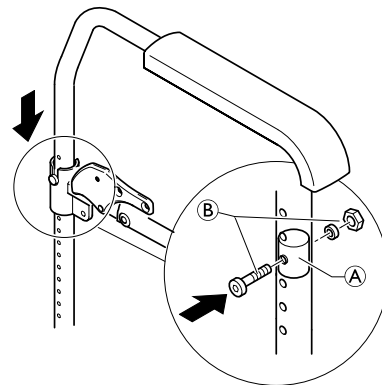

6.5.3 Installing/adjusting the siderest

The rear seat-to-floor height (RSTF) must be at least 420 mm for installing siderests.



Allen key (4 mm, 5 mm) / Phillips screw driver (2 mm)



1. Install the holder ② to the seat module using the screw connections ① and bracket ③.
2. Slightly loosen the grub screw ④ on the adjustment plate ⑤ and adjust the siderest to the required height.
3. Retighten the grub screw.
4. Carry out the same setting on both sides.
5. Tighten or loosen the screws ⑥ to adjust how easy the mudguard can be moved out or into the holder.
6. Mount the cross brace ⑦ between the brackets ③ using bolts ⑧.

① = 7 Nm

④ = 4 Nm

⑧ = 13 Nm

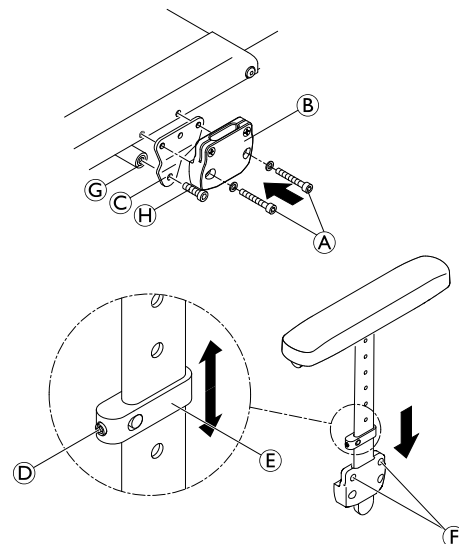

6.6 Castors

6.6.1 Replacing the castor wheel

- !** **IMPORTANT!**
 The following sub-assembly contains pre-coated screws.
 – Only use original Invacare spare parts.
 – If the screws need adjustment, replace by new ones.

Only use original Invacare spare parts. Any change in the adjustment of these screws requires a change of screw.

 Allen key (3 mm) ■ □ □

1. Remove the screws **A** and washers **B**.
2. Remove the castor wheel **D** from the castor fork **C**.
3. Place the sleeves **E** in the bearing of the new castor wheel.
4. Place the castor wheel with sleeves in the required position of the fork.
5. Secure the castor wheel to the fork using screws and washers.

A = 4 Nm

Function check:

The wheel may not wobble, but must rotate easily.

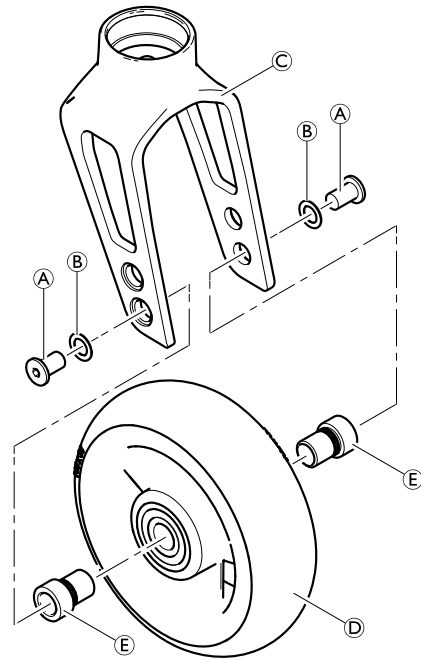

6.6.2 Replacing the castor fork



IMPORTANT!

- The following sub-assembly contains pre-coated screws.
- Only use original Invacare spare parts.
- If the screws need adjustment, replace by new ones.



Socket spanner (10 mm) / Wrench (17 mm)



1. Remove the castor wheel, see 6.6.1 *Replacing the castor wheel*, page 32.
2. Remove bolt ⑥, washer ③, the castor fork ① with bearings ④ and part ⑤ from the threaded bolt ⑦.
3. If necessary, turn the threaded bolt ⑦ out of the supporter ⑧ and replace with a new one. Apply high-strength adhesive on the thread.
4. Replace the castor fork and reinstall in reverse order.

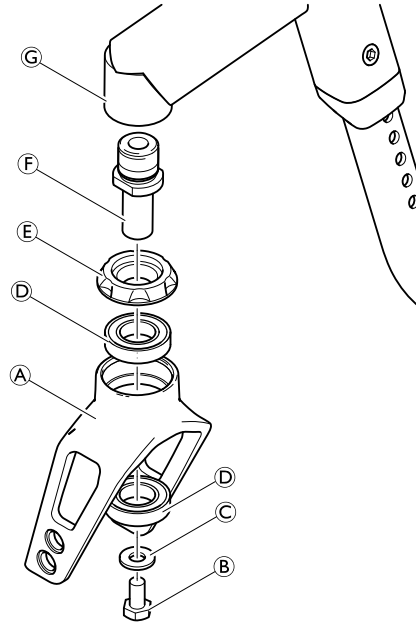

IMPORTANT!

- Risk of damaging the castor fork bearing
- Do not overtighten the bolt ⑥.
- Tighten the bolt only so far that the fork can still be turned freely.

5. Reinstall the castor wheel.

⑦ = 13 Nm (high-strength)

Function check

Tip the wheelchair backwards by 90° so that it is lying on the backrest and the rear wheels. Make sure that the clevis pin is as horizontal as possible. Turn the fork upwards (position A) and let it tip downwards. The fork has been correctly adjusted if it easily turns to slightly beyond the bottommost point (position B) and then maximally turns back to the bottommost point (position C). If the fork turns back over the bottommost point or even swings back and forth, it has not been sufficiently tightened. There is a risk that the castor wheel will start to wobble at high speeds.

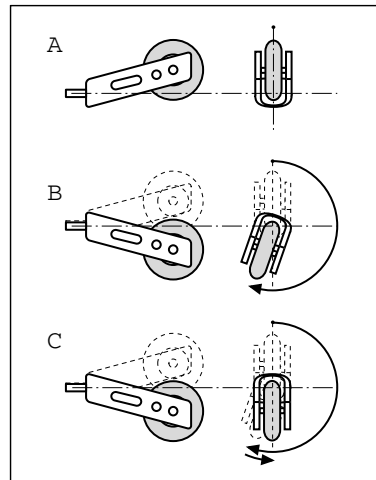

6.7 Rear Wheels



WARNING!

Risk of accidents to the wheelchair user

- Check and adjust the antitipper and parking brake settings after each change on the rear wheel position.

6.7.1 Ensuring the rear wheels are parallel



Allen key (5 mm)



1. Loosen the bolts (A) on both clamp sets.
2. Rotate the axle tube (B) to set the correct position.
3. Retighten the bolts on both sides.

i This setting must be carried out on a horizontal surface. The track of the rear wheels is correct if the distance between the rear wheels is the same at the front and the back ($x=y$) – measured at the height of the centre of the axle.

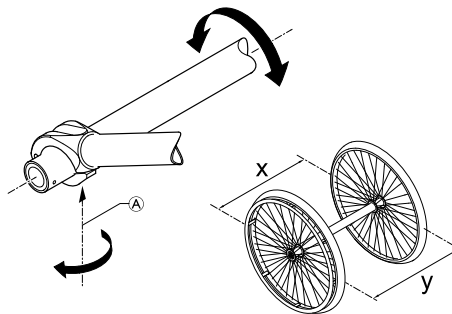

6.7.2 Adjusting the Removable Axle

i Open-end spanner (19) / Straddle spanner (11)



1. Remove the rear wheel.
2. Hold the end of the removable axle (B) using the straddle spanner.
3. Adjust the length L of the removable axle by turning the nut (A). The length is correctly adjusted if the removable axle engages correctly when installing the wheel and the wheel has just minimal clearance.

i The wheels must be exchanged (left to right side and vice versa) after adjusting both removable axles. The adjustment must now be checked or carried out again to ensure the wheels can be switched.

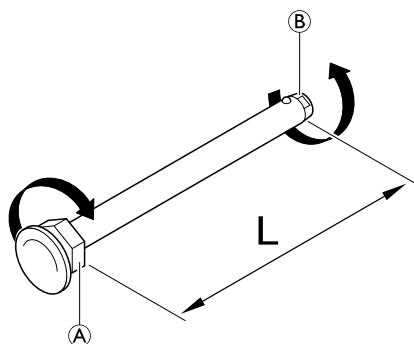

6.7.3 Installing/adjusting the rear wheel extension

i Allen key (3 mm, 4 mm, 5 mm) / Socket spanner (8 mm)



1. Remove both rear wheels.
2. Remove bolt and nut (A) on both sides and remove the axle holder (B) with the axle from the frame (C).
3. Remove the bolt (D) and bolt and nut (E) on both sides and remove the axle holder from the axle.
4. Install the axle locking ring (F) to the required hole in the rear wheel extension (H) using bolts and washers (G). Here, do not yet tighten the screws. Slide the two rear wheel extensions onto the axle.

i If a Vario-Ax is to be installed, another appropriate locking ring must be used.

5. Install the rear wheel extension to both sides of the frame using the bolts and nut (A).
6. Ensure that the rear wheels are parallel, see 6.7.1 *Ensuring the rear wheels are parallel, page 33.*
7. Tighten the screw (I) on the axle locking ring on both sides to fix the axle.
8. Tighten the bolts with washers (G) on both sides.

- (A) = 13 Nm
- (G) = 7 Nm
- (I) = 7 Nm

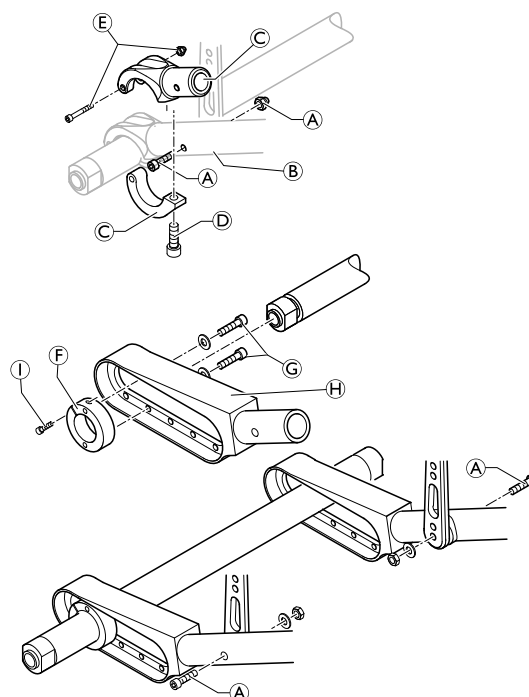

6.7.4 Changing the wheel camber / Installing and adjusting an axle

The following table describes the axle length [mm] in relationship to the seat width (SW) [mm] and the camber angle. The axle length varies depending on whether a clothes-guard or a mudguard/armrest mounted. The axle length is defined as the length of the axle tube (without axle sleeves).

It is possible to install two axles, if a rear wheel extension with five positions is mounted.

Clothes-guard

Camber angle 1. Axle / 2. Axle	SW 320	SW 340	SW 360	SW 380	SW 400	SW 420	SW 440	SW 460	SW 480	SW 500
VA / -	335	355	375	395	415	435	455	475	495	515
0° / -	298	318	338	358	378	398	418	438	458	478
3° / -	304	324	344	364	384	404	424	444	464	484
6° / -	334	354	374	394	414	434	454	474	494	514
VA / VA	335 / 335	355 / 355	375 / 375	395 / 395	415 / 415	435 / 435	455 / 455	475 / 475	495 / 495	515 / 515
VA / 0°	335 / 298	355 / 318	375 / 338	395 / 358	415 / 378	435 / 398	455 / 418	475 / 438	495 / 458	515 / 478
VA / 3°	335 / 304	355 / 324	375 / 344	395 / 364	415 / 384	435 / 404	455 / 424	475 / 444	495 / 464	515 / 484
0° / 0°	298 / 298	318 / 318	338 / 338	358 / 358	378 / 378	398 / 398	418 / 418	438 / 438	458 / 458	478 / 478
0° / 3°	298 / 304	318 / 324	338 / 344	358 / 364	378 / 384	398 / 404	418 / 424	438 / 444	458 / 464	478 / 484
3° / 3°	304 / 304	324 / 324	344 / 344	364 / 364	384 / 384	404 / 404	424 / 424	444 / 444	464 / 464	484 / 484
3° / 6°	324 / 334	344 / 354	364 / 374	384 / 394	404 / 414	424 / 434	444 / 454	464 / 474	484 / 494	504 / 514
6° / 6°	334 / 334	354 / 354	374 / 374	394 / 394	414 / 414	434 / 434	454 / 454	474 / 474	494 / 494	514 / 514

Mudguard / armrest

Camber angle 1. Axle / 2. Axle	SW 320	SW 340	SW 360	SW 380	SW 400	SW 420	SW 440	SW 460	SW 480	SW 500
VA / -	335	355	375	395	415	435	455	475	495	515
0° / -	298	318	338	358	378	398	418	438	458	478
3° / -	324	344	364	384	404	424	444	464	484	504
6° / -	354	374	394	414	434	454	474	494	514	534
VA / VA	335 / 335	355 / 355	375 / 375	395 / 395	415 / 415	435 / 435	455 / 455	475 / 475	495 / 495	515 / 515
VA / 0°	335 / 298	355 / 318	375 / 338	395 / 358	415 / 378	435 / 398	455 / 418	475 / 438	495 / 458	515 / 478
VA / 3°	355 / 324	375 / 344	395 / 364	415 / 384	435 / 404	455 / 424	475 / 444	495 / 464	515 / 484	535 / /504
0° / 0°	298 / 298	318 / 318	338 / 338	358 / 358	378 / 378	398 / 398	418 / 418	438 / 438	458 / 458	478 / 478
0° / 3°	318 / 324	338 / 344	358 / 364	378 / 384	398 / 404	418 / 424	438 / 444	458 / 464	478 / 484	498 / 504
3° / 3°	324 / 324	344 / 344	364 / 364	384 / 384	404 / 404	424 / 424	444 / 444	464 / 464	484 / 484	504 / 504
3° / 6°	344 / 354	364 / 374	384 / 394	404 / 414	424 / 434	444 / 454	464 / 474	484 / 494	504 / 514	524 / 534
6° / 6°	354 / 354	374 / 374	394 / 394	414 / 414	434 / 434	454 / 454	474 / 474	494 / 494	514 / 514	534 / 534

VA = Vario-axle

Installing a standard axle

A new axle must be used to change the wheel camber.



Allen key (5 mm)



1. Remove both rear wheels.
2. Remove the bolts (A) on both sides and open up the lower part of the axle holder (B).
3. Replace the axle (C) with a new one with the desired wheel camber.
4. Ensure that the rear wheels are parallel, see 6.7.1 *Ensuring the rear wheels are parallel, page 33.*
5. Close the lower part of the axle holder on both sides.
6. Reinsert the bolts on both sides and tighten.

(A) = 13 Nm

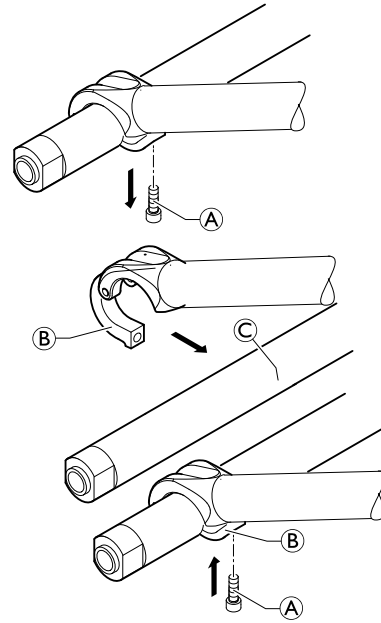

Installing a Vario-axle



Allen key (3 mm, 5 mm) / Socket spanner (8 mm)



1. Remove both rear wheels.
2. Remove the bolts, washers and nuts (A) on both sides and remove the axle holder with the axle.
3. Install the upper part of the Vario-axle holder (B) on both sides using bolts, washers and nuts (A).
4. Insert the Vario-axle (C) and install the lower part of the Vario-axle holder (D) on both sides using bolts and nuts (E) and bolt (F).
5. Set the desired wheel camber, see next paragraph.
6. Ensure the rear wheels are parallel for wheel camber 3° or 7°, see 6.7.1 *Ensuring the rear wheels are parallel, page 33.*

(A) = 13 Nm

(E) = 4 Nm

(F) = 13 Nm

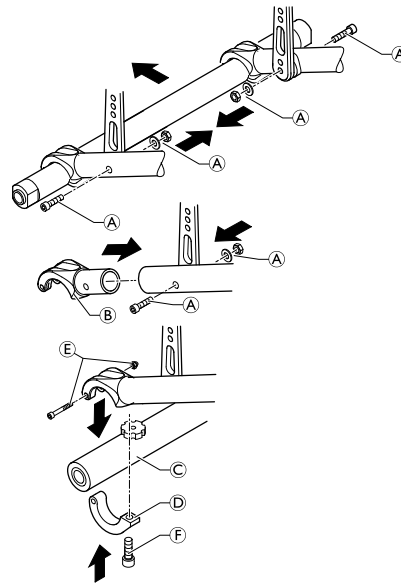

Adjusting a Vario-axle



—



1. Loosen the knurled screw (A) on the Vario-axle.
2. Pull the rear wheel by the wheel hub (B) until the desired wheel camber is set. Possible settings are 1, 3, 7 and 10 degrees.
3. Tighten the knurled screw again (not too tight).

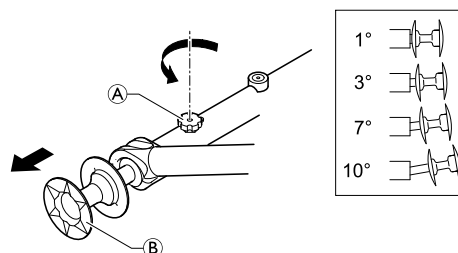

6.7.5 Repairing or changing an inner tube



Tyre lever



1. Remove the rear wheel and release any air from the inner tube.
2. Lift one tyre wall away from the rim using a bicycle tyre lever. Do not use sharp objects such as a screwdriver which could damage the inner tube.
3. Pull the inner tube out of the tyre.
4. Repair the inner tube using a bicycle repair kit or, if necessary, replace the tube.
5. Inflate the tube slightly until it becomes round.
6. Insert the valve into the valve hole on the rim and place the tube inside the tyre (the tube must lie right round the tyre with no creases).
7. Starting close to the valve, push the tyre wall over the edge of the rim using both hands. When doing this, check all the way round to ensure that the inner tube is not trapped between the tyre and the rim.
8. Inflate the tube to its maximum operating pressure. Check that no air is escaping from the tyre.

6.7.6 Replacing a solid tire

Removing a solid tire



Lever bar



1. Push on the side wall of the tire while inserting a lever bar.



Some solid tires are quite a bit smaller than the rim so this can be difficult.

2. Once one lever is in, insert a second lever and push the tire over the rim until it comes off.



If you are unable to push off the tire, it needs to be cut off. Make sure not to damage the rim.

Installing a solid tire

Installing solid tires on a rim can only be accomplished with the right tools. Most of these tires are smaller than the rim they fit and need to be stretched to be installed. Follow the instructions that come with the tools for the process.

6.7.7 Replacing rear wheel spokes

We recommend having the spokes replaced by a qualified technician.

6.8 Parking brakes

6.8.1 Installing the parking brake



Allen key (5 mm)



1. Position the brake holder ⑥ around the front frame tube ③.
2. Place the brake ④ in the brake holder.
3. Screw the bolt ① with washer into the brake assembly but do not tighten.
4. Rotate the brake holder assembly around the frame tube to adjust the lateral distance of the brake.
5. Rotate the brake in the brake holder to achieve a horizontal position of the brake rod ⑤ to the tyre.
6. Fully apply the brake and slide it towards the tyre until the brake rod bears flush against the tire.
7. Release the brake and slide it 3 mm backwards and tighten the bolt.

① = 13 Nm

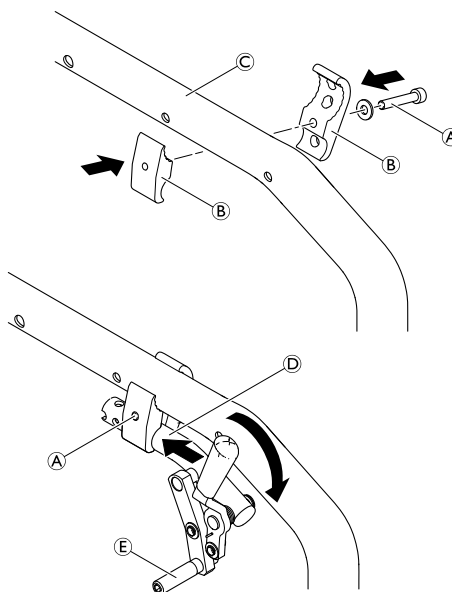

6.8.2 Adjusting the parking brake



Allen key (5 mm)



WARNING!
Risk of injury

- The parking brakes must be readjusted whenever the rear wheels are replaced or the wheel camber is changed.
- The parking brake function is only guaranteed if the tyre has the corresponding inflation pressure.

1. Check the tyre pressure in the rear wheels and correct if necessary.
2. Slightly loosen bolt ① of the brake holder.
3. Change the position of the brake assembly as described in chapter 6.8.1 *Installing the parking brake, page 38*.
4. Tighten the bolt ①.

IMPORTANT!

- The force to apply the parking brake must be 60 N (maximum).



Very little force is required for activating and deactivating the brake. If necessary, a brake lever extension can be mounted.

Visual check

Check that the parking brakes are positioned correctly. The brake is set correctly if the brake rod depresses the tire by no more than 4 mm when the brake is applied. (In the case of push/pull and standard brakes this will be the case when the brake shoe is approx. 25 mm away from the tire when released.)

Function check

Place a weighted wheelchair with parking brake engaged facing uphill and then facing downhill on a ramp with an incline of 7°. The wheelchair must not move.

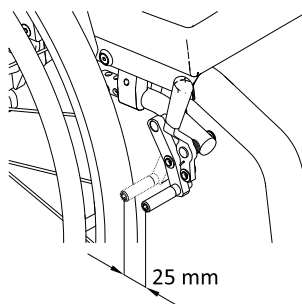

6.9 Options

6.9.1 Installing/adjusting the antitipper

There are two different sizes of antitipper for both the left and the right sides.



Allen key (3 mm, 5 mm) / Socket spanner (8 mm, 10 mm)



Without rear wheel extension

1. Loosen the bolt (A) and bolt and nut (B) and remove the lower part of the axle holder (C).
2. Install the adaptation holder (D) with bolt and nut (B) and bolt (A).
3. Mount the antitipper to the adaptation holder using the round nuts (E) and bolts with washers (F).
4. Measure the distance between the antitipper and the ground and adjust the length of the antitipper according to the below description.
5. Ensure that the rear wheels are parallel, see 6.7.1 *Ensuring the rear wheels are parallel, page 33.*

(A) = 13 Nm

(B) = 4 Nm

(F) = 13 Nm

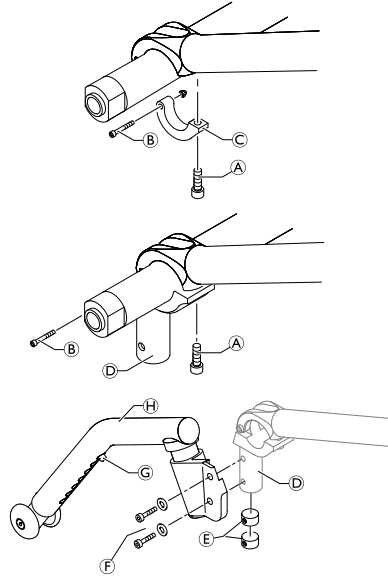

With rear wheel extension

1. Install the adaptation holder (A) to the rear-most position of the rear wheel extension (D) using the spacer parts (B) and bolts, washers and nuts (C).
2. Mount the adaptation holder to the rear wheel extension using the round nuts (E) and bolts with washers (F).

 It may be necessary to widen the existing holes to a diameter of 6.1 mm.

3. Install the antitipper (I) to the adaptation holder using bolts washers and nuts (F).
4. Measure the distance between the antitipper and the ground and adjust the length of the antitipper according to the below description.
5. Ensure that the rear wheels are parallel, see 6.7.1 *Ensuring the rear wheels are parallel, page 33.*

(C) = 13 Nm

(F) = 13 Nm

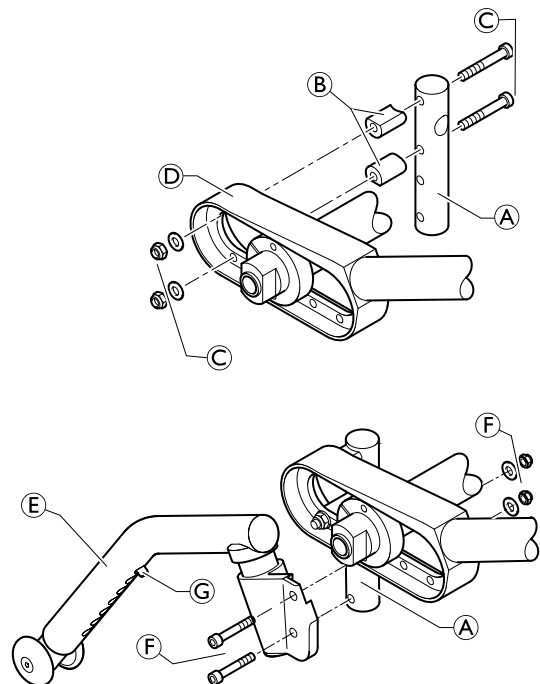

Adjusting the length of the antitipper

1. Press the spring pin (G). Slide the inner part of the antitipper to the required position until the spring pin locates in the correct hole.

Function control:

The distance between the antitipper and the ground must be 50 - 70 mm. It must be easy to fold up the antitipper. Tip the wheelchair backwards using the antitipper until the axle is perpendicular to the antitipper's point of contact with the ground. In this position, the distance between the rear wheel and the ground must be $x \geq 50$ mm.

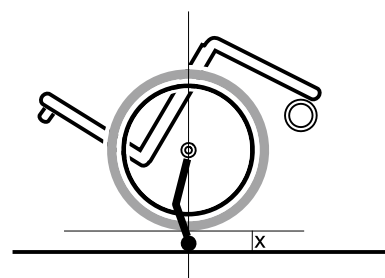

Installing/adjusting the active antitipper



Allen key (3 mm, 5 mm) / Socket spanner (8 mm) / Drill & drill bit (6 mm)



1. Fit the holder **A** to the axle tube. Here, only lightly tighten the bolts **B**.
2. Remove the quick release pin **C**, slide the active antitipper **D** over the holder and reinsert the quick release pin.
3. Turn the antitipper assembly around the axle so that it matches the desired distance from the ground.
4. Remove the quick release pin and carefully pull the antitipper off the holder. The position of the holder must not change.
5. Reinsert the bolts **B** and tighten.
6. For the aluminium axle, not for the Vario-Ax: Once the holder **A** is correctly positioned, drill into the axle from both sides through the corresponding hole in the holder, insert the bolt **E** and secure with nut **F**.

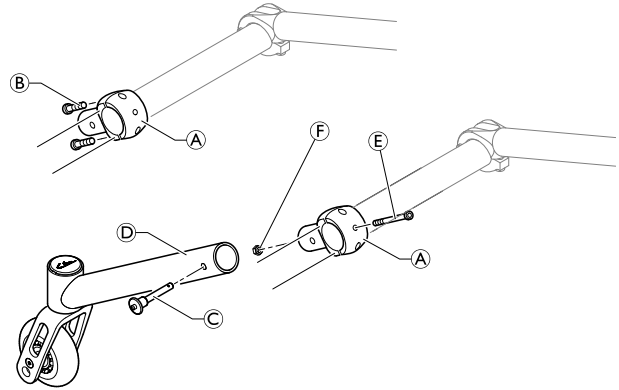

B = 7 Nm

F = 7 Nm



The active antitipper cannot be fitted to a carbon axle.

6.9.2 Installing/adjusting the transit wheels



Allen key (3 mm, 5 mm) / Socket spanner (8 mm)



1. Loosen the bolt **A** and bolt and nut **B** and remove the lower part of the axle holder **C**.
2. Install the adaptation holder **D** with bolt and nut **B** and bolt **A**.
3. Mount the transit wheel **G** to the adaptation holder using the round nuts **E** and bolts with washers **F**.
4. Ensure that the rear wheels are parallel, see 6.7.1 *Ensuring the rear wheels are parallel, page 33*.
5. Install the second transit wheel on the other side.

A = 13 Nm

B = 4 Nm

F = 13 Nm

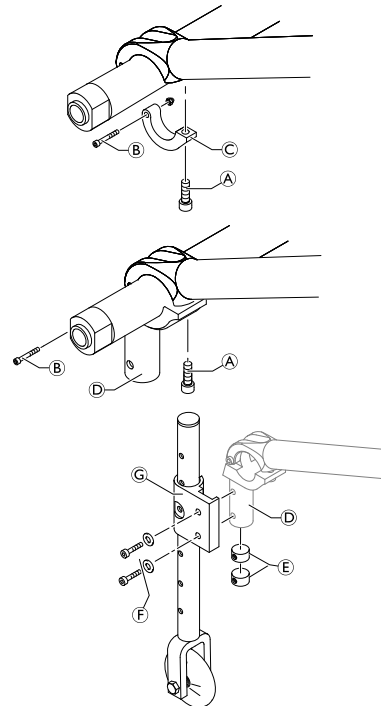

6.9.3 Installing the posture belt

 Allen key (5 mm) / Socket spanner (10)



1. Remove cap nut **A** and washer **C**.
2. Attach the steel strap **D** to the backrest joint screw **B** using the supplied, new cap nut and washer.

A = 7 Nm

WARNING!

Risk of injury due to incorrect installation

– Make sure that the webbing of the posture belt is not twisted during assembly and the locking mechanism shows towards the front.

WARNING!

Risk of injury due to incorrect installation

– Make sure that the seat cover does not get caught between the steel strap and the side supporters during assembly.

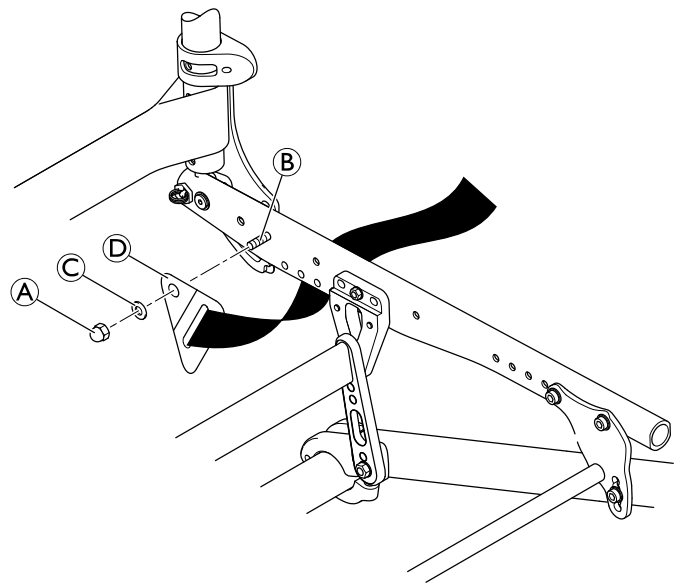

6.9.4 Installing the positioning belt

 Allen key (3 mm)



1. Remove the two bolts **A** and washers **B**.
2. Position the adapter plate **C** against the seat, aligning the hole with the first frame hole, and the groove with second frame hole.

 If necessary, reposition the clamping part of the parking brake.

WARNING!

Risk of injury due to incorrect installation

– Make sure that the parking brakes are positioned correctly to ensure the function.

3. Insert bolts with washers and tighten.
4. Mount the belt **D** to the adapter plate **C** in the required hole using bolt **E** and nut **F**.

 The washer **G** can be placed between the belt and the nut to avoid the rotation of the belt.

 If necessary, reduce the length of the belt by cutting straight across the belt at position **H**. Trim along the curved line **I** for a proper appearance.

A = 5 Nm

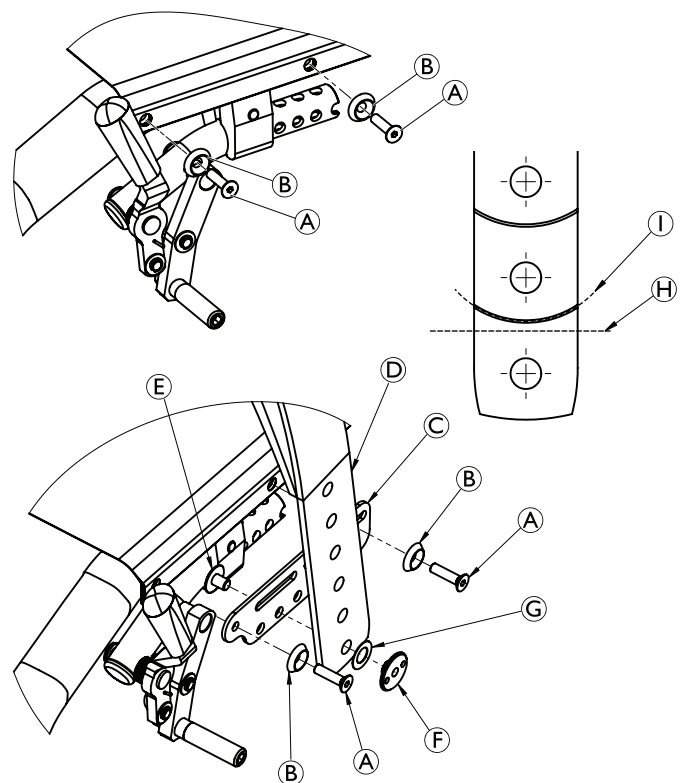

6.9.5 Attaching the snap hook symbol labels

 Before preparing the wheelchair for use as a seat in a motor vehicle, make sure that the configuration is suitable. In doubt contact your Invacare representation.

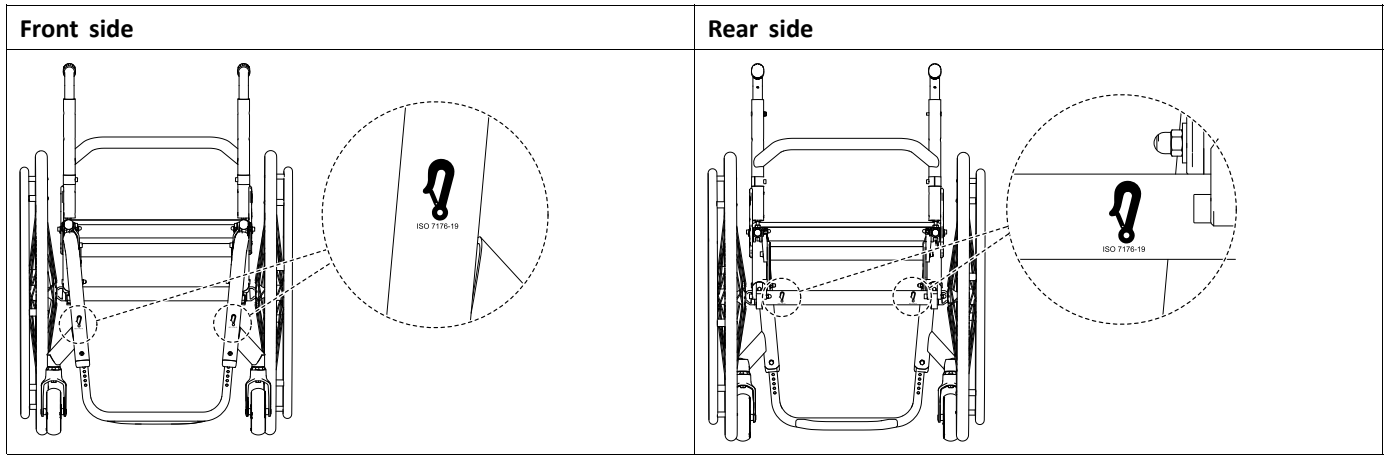

Invacare distributors

Asia:

Invacare Asia Ltd.
1 Lenton Place, North Rocks NSW 2151
Australia
Phone: (61) (02) 8839 5333
Fax: (61) (02) 8839 5343
asiasales@invacare.com
www.invacare.com

Deutschland:

Invacare GmbH
Am Achener Hof 8
D-88316 Isny
Tel: (49) (0)7562 700 0
kontakt@invacare.com
www.invacare.de

Ireland:

Invacare Ireland Ltd,
Unit 5 Seatown Business Campus
Seatown Road, Swords, County Dublin
Tel : (353) 1 810 7084
Fax: (353) 1 810 7085
ireland@invacare.com
www.invacare.ie

Norge:

Invacare AS
Grensesvingen 9, Postboks 6230,
Etterstad
N-0603 Oslo
Tel: (47) (0)22 57 95 00
Fax: (47) (0)22 57 95 01
norway@invacare.com
www.invacare.no

Sverige:

Invacare AB
Fagerstagatan 9
S-163 53 Spånga
Tel: (46) (0)8 761 70 90
Fax: (46) (0)8 761 81 08
sweden@invacare.com
www.invacare.se

Australia:

Invacare Australia Pty. Ltd.
1 Lenton Place, North Rocks NSW 2151
Australia
Phone: 1800 460 460
Fax: 1800 814 367
orders@invacare.com.au
www.invacare.com.au

Eastern Europe, Middle East & CIS:

Invacare EU Export
Am Achener Hof 8
D-88316 Isny
Tel: (49) (0)7562 700 397
eu-export@invacare.com
www.invacare-eu-export.com

Italia:

Invacare Mecc San s.r.l.,
Via dei Pini 62,
I-36016 Thiene (VI)
Tel: (39) 0445 38 00 59
Fax: (39) 0445 38 00 34
italia@invacare.com
www.invacare.it

Österreich:

Invacare Austria GmbH
Herzog-Odilo-Straße 101
A-5310 Mondsee-Tiefgraben
Tel: (43) 6232 5535 0
Fax: (43) 6232 5535 4
info-austria@invacare.com
www.invacare.at

Schweiz / Suisse / Svizzera:

Invacare AG
Benkenstrasse 260
CH-4108 Witterswil
Tel: (41) (0)61 487 70 80
Fax: (41) (0)61 487 70 81
switzerland@invacare.com
www.invacare.ch

Belgium & Luxemburg:

Invacare nv
Autobaan 22
B-8210 Loppem
Tel: (32) (0)50 83 10 10
Fax: (32) (0)50 83 10 11
belgium@invacare.com
www.invacare.be

España:

Invacare SA
Avda. Del Oeste n.50, 1ª, 1ª
Valencia-46001
Tel: (34) (0)972 49 32 14
contactsp@invacare.com
www.invacare.es

Nederland:

Invacare BV
Galvanistraat 14-3
NL-6716 AE Ede
Tel: (31) (0)318 695 757
Fax: (31) (0)318 695 758
nederland@invacare.com
www.invacare.nl

Portugal:

Invacare Lda
Rua Estrada Velha, 949
P-4465-784 Leça do Balio
Tel: (351) (0)225 1059 46/47
Fax: (351) (0)225 1057 39
portugal@invacare.com
www.invacare.pt

United Kingdom:

Invacare Limited
Pencoed Technology Park, Pencoed
Bridgend CF35 5AQ
Tel: (44) (0) 1656 776 222
Fax: (44) (0) 1656 776 220
uk@invacare.com
www.invacare.co.uk

Danmark:

Invacare A/S
Sdr. Ringvej 37
DK-2605 Brøndby
Tel: (45) (0)36 90 00 00
Fax: (45) (0)36 90 00 01
denmark@invacare.com
www.invacare.dk

France:

Invacare Poirier SAS
Route de St Roch
F-37230 Fondettes
Tel: (33) (0)2 47 62 64 66
Fax: (33) (0)2 47 42 12 24
contactfr@invacare.com
www.invacare.fr

New Zealand:

Invacare New Zealand Ltd
4 Westfield Place, Mt Wellington 1060
New Zealand
Phone: 0800 468 222
Fax: 0800 807 788
sales@invacare.co.nz
www.invacare.co.nz

Suomi:

Camp Mobility
Patamäenkatu 5, 33900 Tampere
Puhelin 09-35076310
info@campmobility.fi
www.campmobility.fi



Invacare France Operations SAS
Route de St Roch
F-37230 Fondettes
France

