



©2017 Kuschall AG

All rights reserved. Republication, duplication or modification in whole or in part is prohibited without prior written permission from Kuschall AG. Trademarks are identified by <sup>TM</sup> and ®.  
All trademarks are owned by or licensed to Kuschall AG or its subsidiaries unless otherwise noted.



## TABLE OF CONTENTS

<b>GENERAL</b> .....	<b>4</b>
Introduction	4
Spare parts and adaptations	4
Fastening with hexagon socket bolts	4
Torque	5
Checks	5
Identifying and repairing faults	5
<b>OVERVIEW</b> .....	<b>6</b>
Components	6
Dimensions	6
<b>SEAT</b> .....	<b>7</b>
Seat width (SB)	7
Seat depth (ST)	7
Rear seat-to-floor height (SHh)	7
Rear seat height adjustment – Low impact system	8
Rear seat height adjustment – without Low impact system	9
Tipping point adjustment	10
Front seat-to-floor height (SHv)	12
Seat angle (SW)	12
<b>BACKREST</b> .....	<b>13</b>
Backrest height (RH)	14
Adjusting the backrest height	14
Securing/adjusting the release cord	14
Replacing the backrest tube	15
Backrest angle (RW)	16
Replacing the handle	17
Replacing foldable push handles	17
<b>FOOTRESTS</b> .....	<b>18</b>
Lower leg length (UL)	18
Replacing footrests	18
Adjusting the footrest height	18
Fitting and adjusting high-mounted footrest	19
Angle-adjustable footplate, adjusting the angle	19
<b>SIDE PARTS</b> .....	<b>20</b>
Clothes-guard/mudguard	20
<b>FRONT WHEELS</b> .....	<b>22</b>
Replacing a front wheel	22
Replacing a front wheel fork	22
<b>REAR WHEELS</b> .....	<b>23</b>
Control of rear wheel parallelism	23
Adjusting the removable axle	23
Rear wheel axle replacement	24
<b>BRAKES</b> .....	<b>25</b>
Parking brakes	25
<b>OPTIONS &amp; ACCESSORIES</b> .....	<b>26</b>
Antitipper assembly and adjustment	26
Fitting the posture belt	26



## GENERAL

### Introduction

This service manual is part of the instructions and contains the technical information for servicing, configuring and repairing a küschall® wheelchair.



#### WARNING!

**Danger of accident and severe injuries.**

**If the wheelchair is improperly set it can cause accidents and severe injuries.**

▸ **Changes to the wheelchair may only be carried out by the dealer.**

To guarantee the required safety and reliability, all wheelchairs must be comprehensively checked once a year.

In part, assembly and adjustment require extensive experience. For this reason, the following assembly instructions have been split into three categories:

Requirement	Symbol
Easy – technical understanding required	●○○
Medium – technical knowledge required	●●○
Difficult – technical knowledge and expertise in assembling wheelchairs required	●●●

The required tools and their respective sizes are listed above each instruction. The instructions include information on the torques with which the respective screw connections must be tightened. Adhering to the given torques requires the use of a torque spanner.

Tool	Symbol
Allen key	◆ 3, 4, 5, 8
Phillips screwdriver	✕ 2
Open-end spanner	—C 8, 10, 11, 19
Socket spanner/Box spanner	◇ 8, 10

### Spare parts and adaptations

All spare parts may be obtained from the küschall® Customer Service department. An electronic spare parts catalogue can be found at [www.kuschall.com](http://www.kuschall.com). Only original spare parts may be used. The written authorisation of Küschall AG must be obtained before installing additional adaptations on a küschall® wheelchair.

### Fastening with hexagon socket bolts

Hexagon socket bolts are not designed to withstand an excessive application of force. When tightening or undoing a hexagon socket bolt, force must be applied to the nut wherever possible to avoid damaging the bolt.

#### Tightening and undoing

- Turn the nut using a socket spanner (only use an open-end spanner if there is insufficient space), using the Allen key simply to stop the bolt turning.

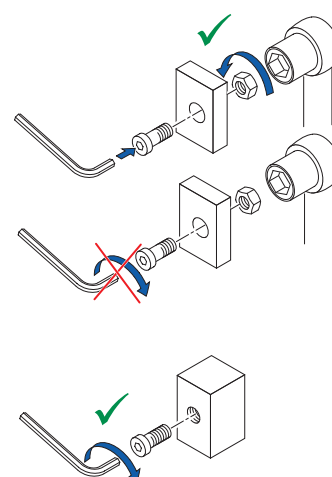



## Tightening and undoing when no nut is present

If a hexagon socket bolt is screwed directly into a thread, the bolt must be tightened using the Allen key



Ensure that the Allen key is of good quality and not worn.

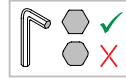

## Torque

- All bolts must be tightened with the torque specified in the following instructions.

## Checks

### Visual check

- Check all components for cracks, especially the areas around joints and welded seams.

### Checking the screw connections

- Check all bolts with the torques specified in the instructions regularly, and adjust if required.



### CAUTION!

Several screw connections have been secured with thread locking adhesive. If these are opened, they must be secured again using new thread locking adhesive.

Liquid high-strength and low-strength adhesives are available. For torque entries notice shall be made whether an adhesive and which adhesive needs to be used.

## Identifying and repairing faults

Fault	Possible cause	Action
The wheelchair does not travel in a straight line	Incorrect tyre pressure on one rear wheel	Correct tyre pressure
	One or more spokes broken	Replace broken spoke(s)
	Spokes tightened unevenly	Tighten loose spokes
	Front wheel bearings are dirty or damaged	Clean or replace the bearings
The wheelchair tips too easily	Backrest angle too large	Reduce backrest angle
	Wrong seat position	Change seat position
The brakes are gripping poorly or asymmetrically	Incorrect tyre pressure in one or both rear tyres	Correct tyre pressure
	Brake setting incorrect	Correct brake setting
The rolling resistance is very high	Tyre pressure in rear tyres is too low	Correct tyre pressure
	Rear wheels are not parallel	Make rear wheels parallel
	Front wheel axles are restrained by dirt or hair	Clean front wheel axles
	Bearings are dirty or faulty	Replace the bearings
The front wheels wobble when moving fast	Too little tension on the clevis pin housing	Tighten the nut on the castor fork slightly
	Front wheel is worn flat	Replace front wheel
The front wheel is stiff or stuck	Bearings are dirty or faulty	Replace the bearings



## OVERVIEW

### Components

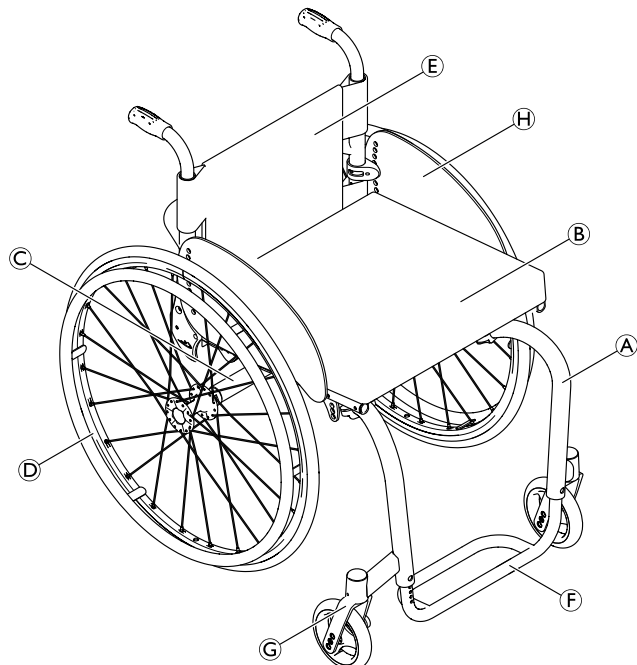

(A)	Frame
(B)	Seat
(C)	Axle tube
(D)	Rear wheel with handrim
(E)	Backrest
(F)	Footrest
(G)	Castor fork with castor
(H)	Clothes-guard

### Dimensions

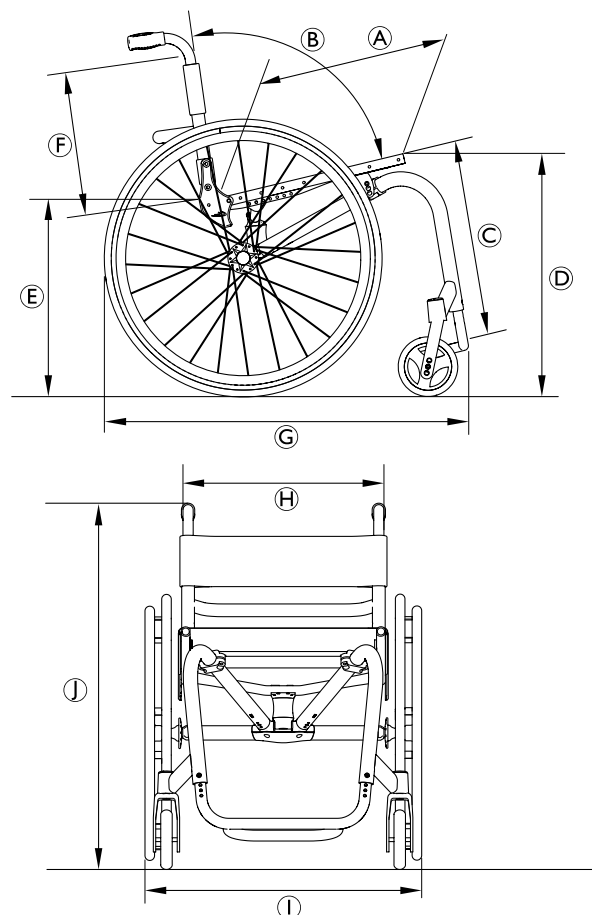

(A)	Seat depth	350 – 450 mm, in increments of 25 mm
(B)	Backrest angle	74°/78°/82°/86°/90°
	Seat plane angle	0° – 12°
(C)	Knee-to-heel length	300 – 480 mm, in increments of 10 mm
	Leg to seat surface angle	63° – 115°
(D)	Seat height front	460 – 510 mm, in increments of 10 mm
(E)	Seat height rear	430 – 480 mm, in increments of 10 mm
(F)	Backrest height	270 – 465 mm, in increments of 15 mm
(G)	Overall length	760 – 830 mm
(H)	Seat width	340 – 440 mm, in increments of 20 mm
(I)	Overall width	510 – 745 mm
(J)	Overall height	700 – 1000 mm



## SEAT

### Seat width (SB)

Available seat widths: SB 340 to SB 440, in 20 mm steps.

Once it has been set the seat width cannot be modified easily. It requires replacing the seat module, possibly the centerpart, the backrest, axle and possibly the footrest. This modification is not described in the service manual.

### Seat depth (ST)

Available seat depths: ST 350 to ST 450 in 25 mm steps.

Adjusting the seat depth requires replacing the entire seat module including seat upholstery and rail, as well as the seat cushion.

### Rear seat-to-floor height (SHh)

Available rear seat heights: SHh 420 to SHh 490 in 10 mm steps.

To adjust the rear seat height it is necessary to change the rear suspension configuration of the spring (or fixed connection piece) and distance rings.

→ Chap. Seat; Rear seat height adjustment with/without „Low-Impact-System“.

The following configurations are possible:

Rear seat-to-floor height by rear wheel size				
SHh	with low impact system		without low impact system	
	24" wheel	25" wheel	24" wheel	25" wheel
420	—	—	1	—
430	1	—	2	1
440	2	1	3	2
450	3	2	4	3
460	4	3	5	4
470	5	4	6	5
480	—	5	7	6
490	—	—	—	7

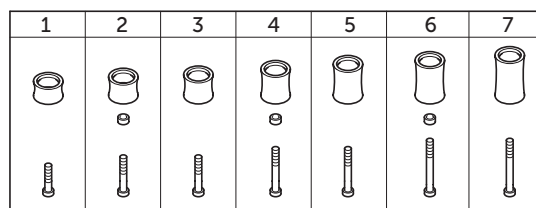
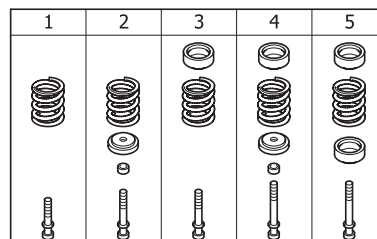



## Rear seat height adjustment – Low impact system

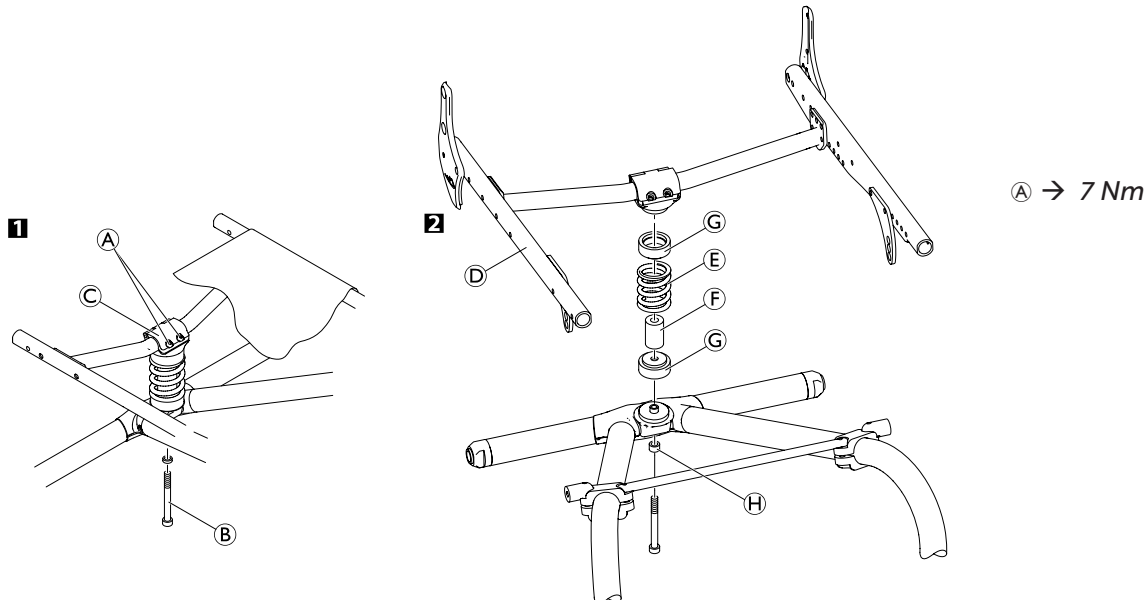

Difficulty: ●●●

Tool: ●5, 8

- 1** Loosen the bolts **A** and remove bolt **B** with sleeve **H** (if fitted) and O-ring.
- 2** Lift up the seat module **D** and remove the spring **E**, elastomer **F** and distance rings **G** (if fitted).
- Insert spring **E**, elastomer **F** and distance rings **G** according to the required rear seat height, → Table Rear seat-to-floor height by rear wheel size (SHh).
- Turn the clamp **C** on the seat module **D** against the spring unit, until all parts fit together.
- Fasten the spring unit with sleeve **H** (If fitted) and O-ring and bolt **B** (with adhesive). Make certain to use the correct bolt length, → Table Rear seat-to-floor height by rear wheel size (SHh).
- Tighten the bolts **A**.





## Rear seat height adjustment – without Low impact system

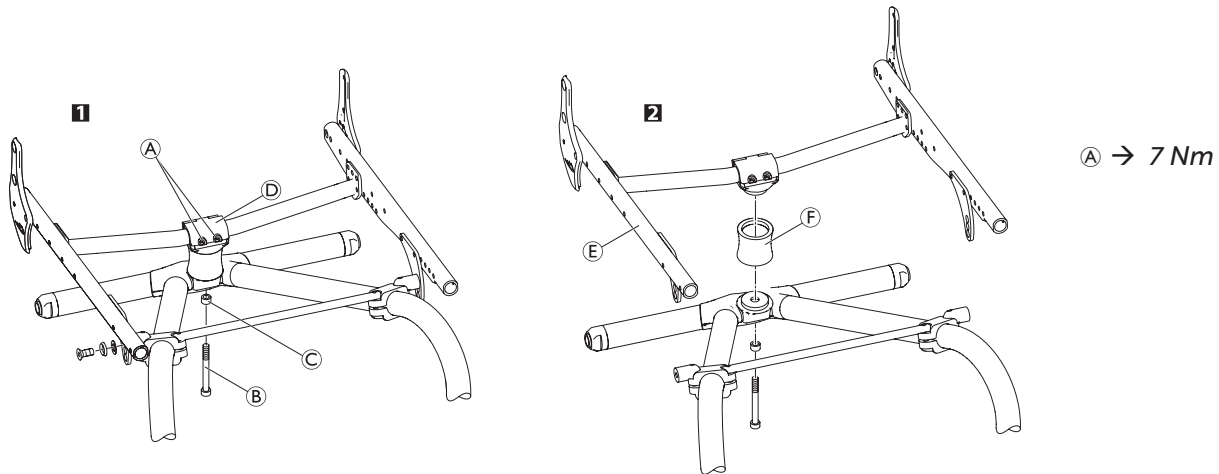

Difficulty: ●●●

Tool: ●5, 8

- 1 Loosen the bolts **A** and remove bolt **B** and ring **C** (if fitted).
  - 2 Lift up the seat module **E** and remove the seat-to-frame connection **F**.
- Insert seat-to-frame connection **F**, according to the requested rear seat height, → Table Rear seat-to-floor height by rear wheel size (SHh).
  - Turn the clamp **D** on the seat module **E** against the seat-to-frame connection, until all parts fit together. Fasten the seat-to-frame connection with the bolt **B** (with adhesive). Slide ring **C** onto the bolt if necessary, → Table Rear seat-to-floor height by rear wheel size (SHh).
  - Tighten the bolts **A**.



## Tipping point adjustment

The tipping point of the wheelchair can be adjusted by changing the horizontal position of the seat module.

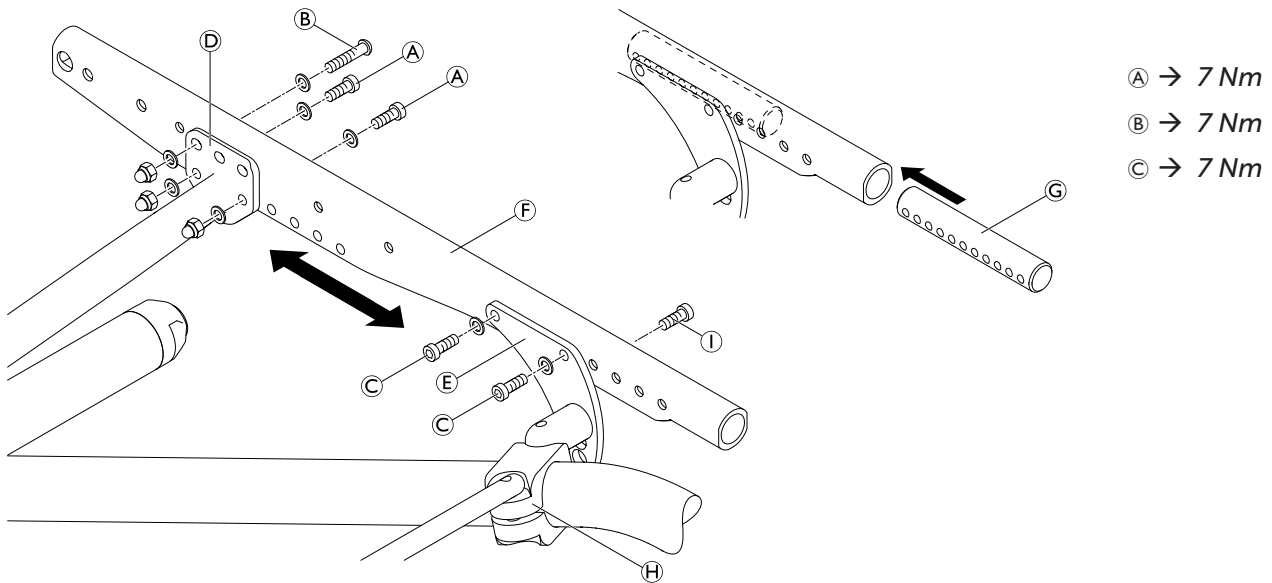

### Making it easier to tip the wheelchair

Difficulty: ●●●

Tool: ● 4, 5

- Remove bolts **A** (=4 bolts that connect the rear brace **D** and the seat module **F**).
- Remove bolts **B** (=2 bolts that connect the rear brace **D**, the seat module **F** and the seat cover).
- Remove bolts **C** (=4 bolts that connect the front brace **E** and the seat module **F** and the insert **G**).
- Move the rear brace and front brace forward to the required position of the seat module.

**i** If necessary the insert **G** has to be shifted inside the seat module tube. Remove bolt **I** for fastening the seat cover, shift insert **G** and re-insert bolt **I** and tighten.

- Re-insert new bolts and tighten.

### Making it more difficult to tip the wheelchair

Difficulty: ●●●

Tool: ● 4, 5

- Remove bolts **A** (=4 bolts that connect the rear brace **D** and the seat module **F**).
- Remove bolts **B** (=2 bolts that connect the rear brace **D**, the seat module **F** and the seat cover).
- Remove bolts **C** (=4 bolts that connect the front brace **E** and the seat module **F** and the insert **G**).
- Move the rear brace and front brace backwards to the required position of the seat module.

**i** If necessary the insert **G** has to be shifted inside the seat module tube. Remove bolt **I** for fastening the seat cover, shift insert **G** and re-insert bolt **I** and tighten.

- Re-insert new bolts and tighten.



**Seat position and tipping point**

Seat position (1=rearmost, 5=frontmost seat position)	Dimension x (the larger the value of x, the easier it is to tip the wheelchair)	Front brace (1=frontmost, 5=rearmost position of brace at seat module)	Rear brace (1=frontmost, 5=rearmost position of brace at seat module)
1	115	1	1
2	100	2	2
3	85	3	3
4	70	4	4
5	55	5	5

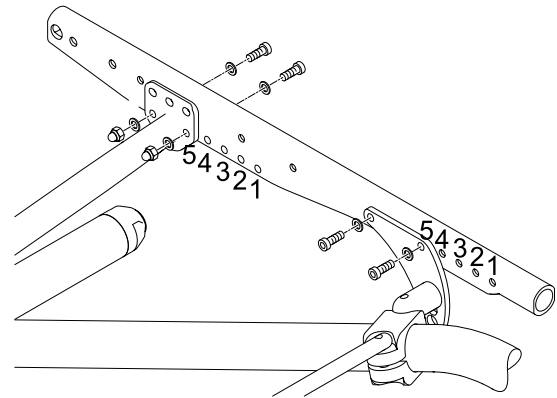
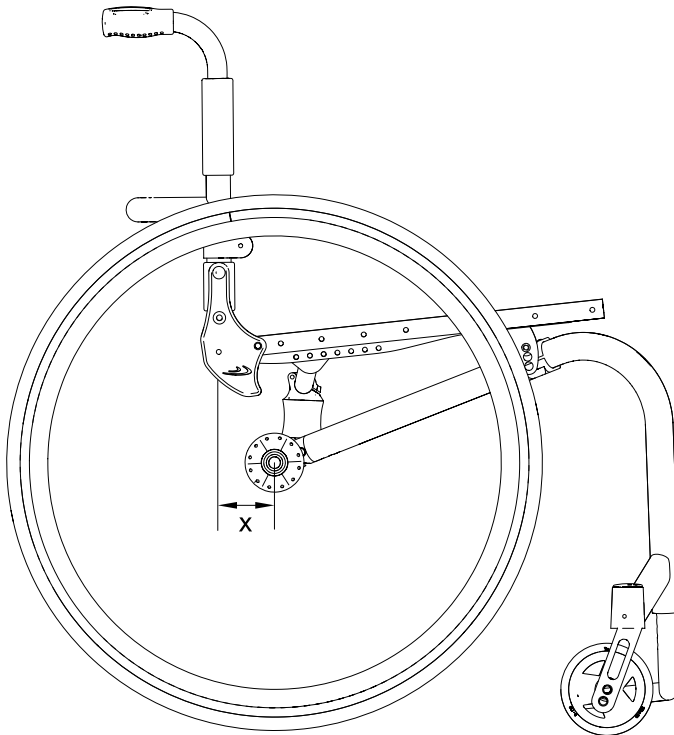



## Front seat-to-floor height (SHv)

The front seat height is variable between SHv 460 and SHv 510 (± 10 mm).

The front seat height is dependent on several factors that interact with each other. In addition to the size of the rear wheels, the frame, seat depth and rear seat height influence the seat height.

The following combinations of front and rear wheels are possible:

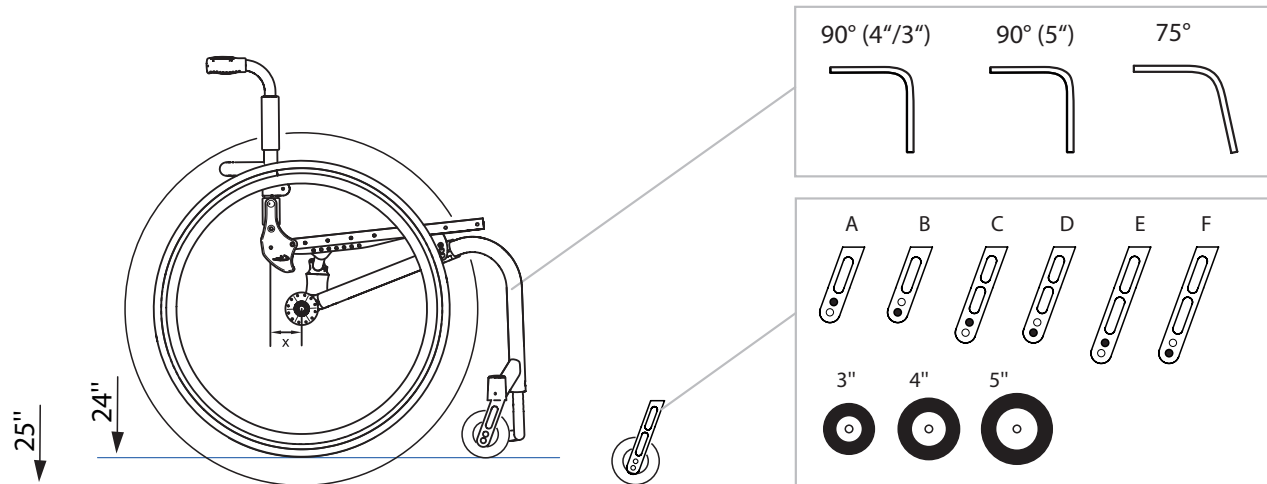

Front and rear wheel combination				
Rear wheel	Frame	Front wheel		
		● 3"	● 4"	● 5"
24"	75°	D	C	B
	90° (3"/4")	B	A	—
	90° (5")	—	—	B
25"	75°	E	D	C
	90° (3"/4")	C	B	—
	90° (5")	—	—	C

 Only choose wheel and axle combinations specified in the table to ensure that the frame is straight and the axis of the front wheel fork is perpendicular to the ground.

To achieve the desired front seat height, there are three frames of different heights available (long, medium, short):

SHv [mm]	Rear wheel	
	24"	25"
460	S	-
470	M	S
480	M	M
490	L	M
500	L	L
510	-	L

## Seat angle (SW)

The seat angle is determined by the difference between the rear seat height (SHh) and the front seat height (SHv).



## BACKREST

The adjustable back is fitted with velcro bands and a cover. Apart from the adjustable back there is the light cover, which is produced individually for each backrest height (RH) and seat width (SB).

<i>Backrest height (RH) to cover, backrest tube, pushhandles and bands</i>					
RH	cover	backrest tube <sup>⑩</sup>	standard pushhandles <sup>①</sup> foldable pushhandles <sup>②</sup>		top band
			pushhandle <sup>①</sup> telescopic tube straight <sup>②</sup>	bands above stabilizing bar	
270	S	S	S	1-band <sup>⑦</sup>	10 cm backrestband, 2 parts <sup>⑤</sup>
285	S	S	S	1-band <sup>⑦</sup>	
300	S	S	S	1-band <sup>⑦</sup>	
315	S	L	S	1-band <sup>⑦</sup>	
330	S	L	S	2-bands <sup>⑧</sup>	
345	M	L	S	2-bands <sup>⑧</sup>	
360	M	L	S	2-bands <sup>⑧</sup>	
375	M	L	S	2-bands+1-band	
390	M	L	L	2-bands+1-band	
405	M	L	L	2-bands+1-band	
420	L	L	L	2-bands+1-band	
435	L	L	L	4-bands <sup>⑨</sup>	
450	L	L	L	4-bands <sup>⑨</sup>	
465	L	L	L	4-bands <sup>⑨</sup>	

<i>Backrest height (RH) to pushhandles, telescopic tubes and bands</i>			
RH	without pushhandles <sup>③</sup>		
	bands above stabilizing bar	top band	telescopic tube bended <sup>③</sup>
270	1-band <sup>⑦</sup>	endband, 10 cm <sup>⑥</sup>	S
285	1-band <sup>⑦</sup>		S
300	1-band <sup>⑦</sup>		S
315	1-band <sup>⑦</sup>		S
330	2-bands <sup>⑧</sup>		S
345	2-bands <sup>⑧</sup>		S
360	2-bands <sup>⑧</sup>		S
375	2-bands+1-band		M
390	2-bands+1-band		M
405	2-bands+1-band		M
420	2-bands+1-band		M
435	4-bands <sup>⑨</sup>		L
450	4-bands <sup>⑨</sup>		L
465	4-bands <sup>⑨</sup>		L

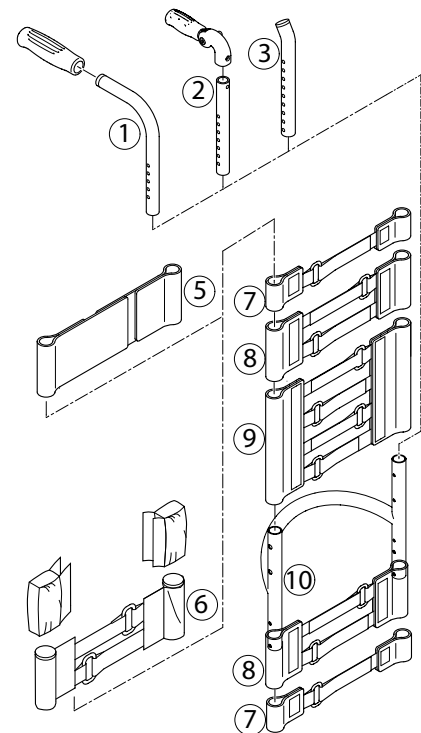

A 1-band strap <sup>⑦</sup> is placed beneath the stabilizing bar if there is a clothes-guard, and a 2-bands strap <sup>⑧</sup> if there is a mudguard.



## Backrest height (RH)

The height of the backrest can be adjusted by moving the backrest tube.

### Adjusting the backrest height

#### Readjusting the push handle/telescopic tube

Difficulty: ●○○

Tools: ● 3 ○ 8

- Remove the backrest padding.
- Remove the screw connection ① and adjust the desired height of the push handle or the telescopic tube. Insert the screw connection ① again and tighten the nut.
- Carry out the same setting on both sides.
- Refit the backrest padding.

 If the desired height cannot be achieved, you must use a different telescopic tube or push handle.

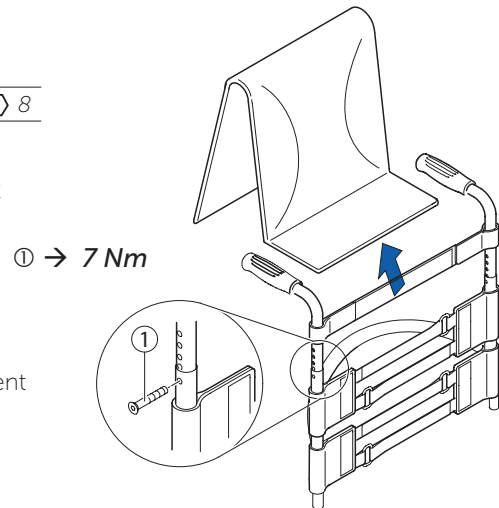

### Securing/adjusting the release cord

Difficulty: ●○○



#### WARNING!

**Risk of injury to the user during use as a result of the backrest folding over unintentionally.**

If the release cord is too taut, the locking mechanism ② can open unintentionally.

→ Make sure that the release cord is not too taut.

- Knot the release cord ①, left and right, to the wire rings ② such that it is free from tension, but still ensuring that there is only minimal slack (< 5 mm).

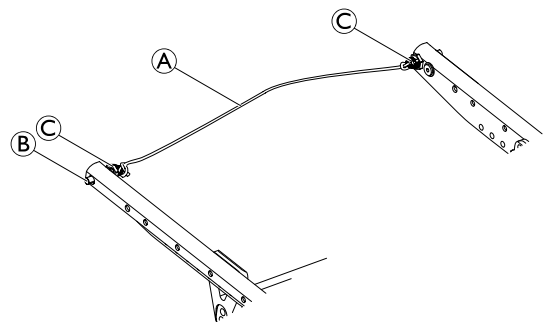



## Replacing the backrest tube

Difficulty: ●○○

Tools: ● 3, 4 ○ 8, 10

- 1** Remove the backrest padding.
  - Slide the backrest bands upwards or downwards to gain access to the screws **A**. Remove the screws and nuts on both sides.
  - Remove the push handles or the telescopic tubes and remove the upper Velcro® bands.
  - Remove the screws **B** on the backrest joint.
- 2** Remove the lower Velcro® bands and the sleeve **D** with the adjustment screw **E** from the backrest tube **C** and fit both to the new backrest tube.
  - Fit the backrest tube to the backrest joint with the screws **B**. Here, first fit the lower screw followed by the upper screw.
  - Fit the upper Velcro® bands and the push handles or the telescopic tubes again and fix them with screws **A** and nuts.
  - Carry out the same setting on both sides.
  - Refit the backrest padding.



The excentre plates must be adjusted identically on both sides of the wheelchair, → Adjusting the backrest angle.

### Check:

Check the settings of the adjustment screws **E** on both sides. The screw head must only lightly touch the seat module when the backrest is in the upright position. If necessary, readjust the length by releasing the counter nut and tightening or loosening the adjustment screw. Then retighten the counter nut **F**.



Incorrectly adjusted adjustment screws result in damage to the backrest joint's mechanism, → Adjusting the backrest joint.

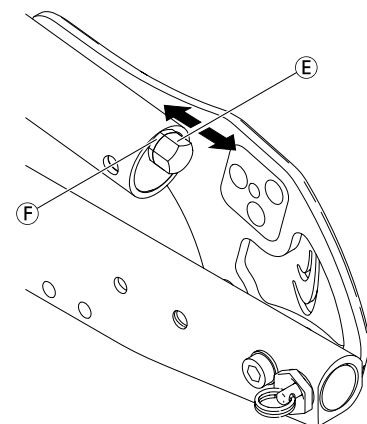
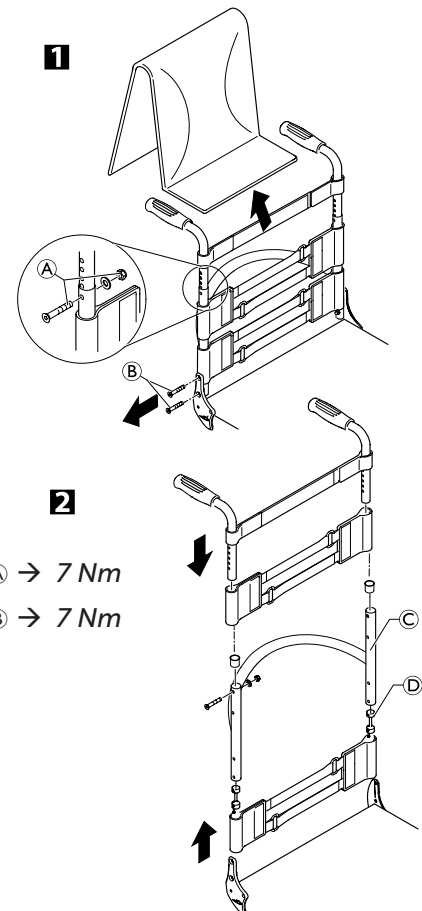



### Backrest angle (RW)

The angle of the backrest can be changed by repositioning the excenter plate in the backrest joint plate.

The following angles (measured from the seat) can be set:

74°	78°	82°	86°	90°

### Adjusting the backrest angle

Difficulty: ●●○

Tools: ● 3, —C 10

- 1 Fold down the backrest and release the counter nut of the adjustment screw **A** and screw it in completely.
- 2 Remove the screw **B** on the excenter plate **C**. Remove the excenter plate **C** and reinsert it in the desired position.

The excenter plates must be set identically on both sides of the wheelchair.

- Reinsert the screw **B** and tighten it. **B** → 4 Nm
- Adjust the backrest joint, see below. **E** → 7 Nm
- Put the backrest up and let the pin **A** engage.
- Press the backrest forwards to ensure the joint cannot move.
- Unscrew the screw **F** until it touches the seat frame **G**.
- Screw the screw back in by between a 1/4 and a 1/2 turn and counter with the counter nut **E**.
- Correctly adjust the backrest joint on both sides.

#### Function check:

Sit in the wheelchair and lean back so that the backrest is strained. Upon pulling the release cord **H**, the pin **D** must be easily removed on both sides and must fully glide back in upon letting go of the release cord.

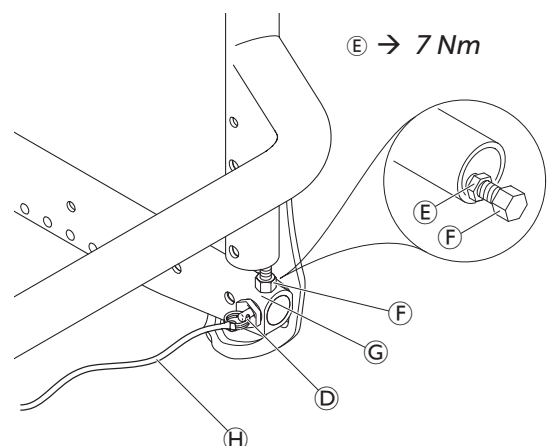
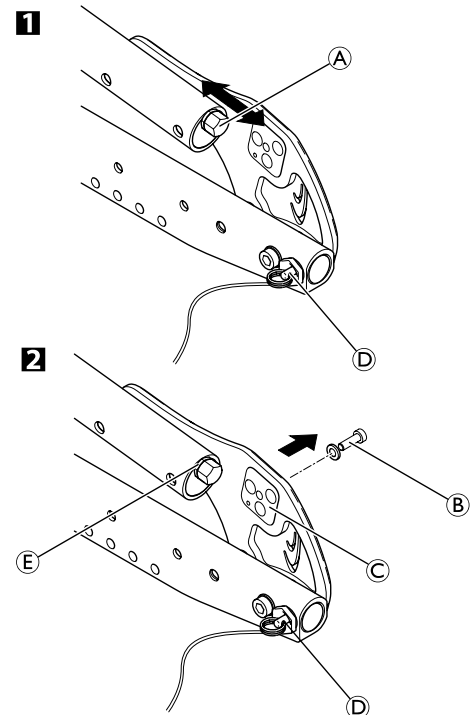





### Replacing the handle

An adhesive (e.g. mounting spray) is used in these instructions. When applied to the handle, this substance works as a lubricant and as an adhesive once dry.



After drying, the adhesive used must be able to resist a pull-off force of 750 N. If in doubt, contact Küschall AG.

Difficulty: ●●○

- Remove the old handle.
- Remove any residue (residual adhesive, grease, dust) from the push handle tube.
- Apply a thin layer of mounting spray all over the surface of the push handle tube onto which the handle is to be slid.
- Apply a thin layer of mounting spray to the inside of the handle.
- Slide the new handle onto the push handle tube.
- Move the handle into the correct position (grooves facing upwards).



If a long handle has been fitted and this is to be replaced with a short one, the push handle tube must be shortened by 35 mm. The push handle tube must be replaced when switching from a short to a long handle.

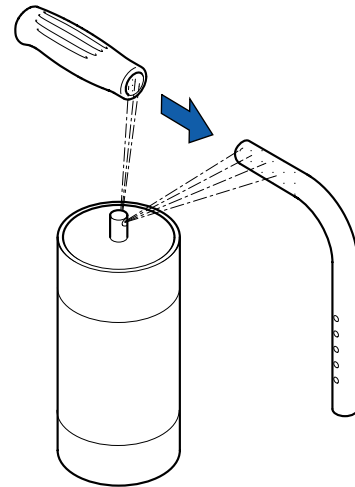

### Replacing foldable push handles

Difficulty: ●○○

Tools: Hole punch pliers 6 mm, ● 3, 4

- Remove the old foldable push handle.
- Pull down the backrest cover (F) on the telescopic tube, until its hole (B) is uncovered.
- ! **IMPORTANT!**
  - Make sure that the threaded insert (E) (part no. 1580450) supplied with the new push handle is used for assembly.
- Place the threaded insert (E) in the telescopic tube.
- Punch a hole through the backrest cover with a distance of 10 mm from the upper edge, using hole punch pliers (see graphic below).
- Slide the new foldable push handle (A) onto the telescopic tube.
- Pull up the backrest cover, until it covers completely the rear hole in the pushhandle.
- Fix the foldable push handle with screw (C) and washer (G).
- Check screws (D) on both sides of the push handle and re-tighten if necessary.
- Carry out the same steps for the other push handle.



Make sure that the folding force is approximately 5 N (0.5 kg).



Fixing screw (C) may only be used once. Alternatively the screw can be cleaned (remove old thread locking adhesive) and reinstalled with new low-strength thread locking adhesive.



The retrofit of foldable push handles requires new tubing.

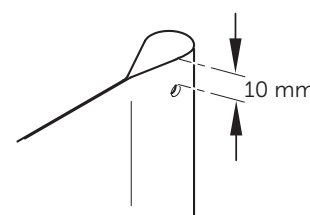
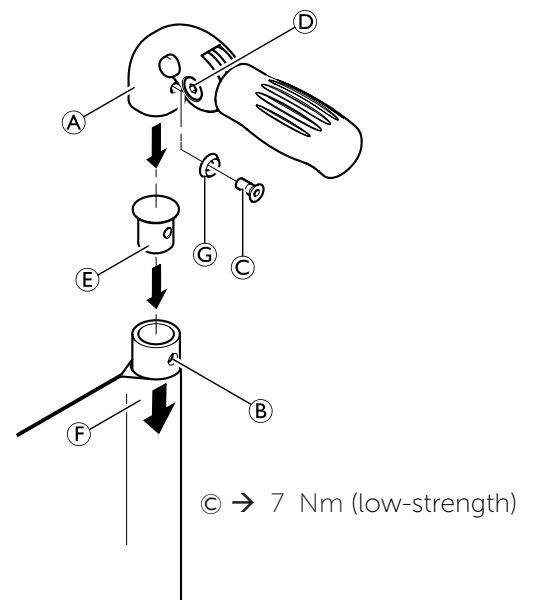



## FOOTRESTS

The footrest must be selected in accordance with the seat width. A standard footrest and an angle-adjustable footrest are available. Furthermore, there is the possibility of a high-mounted footrest.

### Lower leg length (UL)

To change the lower leg length, the footrest can be fixed at a higher or lower position. → Table, Chap. Frame. The shortest lower leg lengths can be achieved using the high-mounted footrest.  
→ Fitting and adjusting high-mounted footrest

### Replacing footrests

Difficulty: ●○○

Tools: ● 4 8

- Remove the screw connections (A) on both sides.
- Remove the footrest and replace it with a new one.
- Tighten the screw connections (A) on both sides.
- Carry out the same setting on both sides.

(A) → 7 Nm

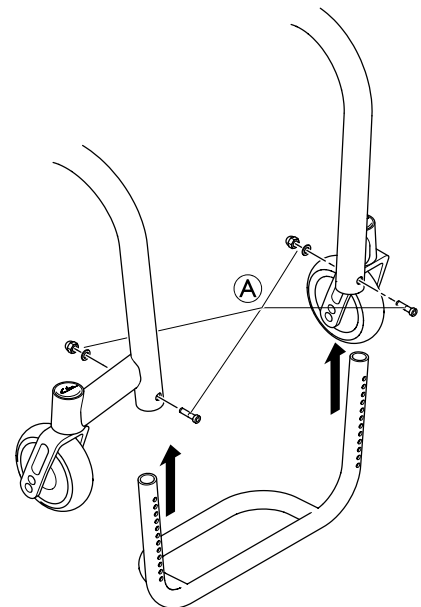

### Adjusting the footrest height

Difficulty: ●○○

Tools: ● 4 8

The height of the footrest can be adjusted in 10 mm steps.

- Remove the screw connections (A) on both sides.
- Slide the footplate to the desired height.
- Tighten the screw connections (A) on both sides.
- Carry out the same setting on both sides.

 If the desired lower leg length cannot be achieved, a high-mounted footrest must be used → <Fitting and adjusting a high-mounted footrest>

(A) → 7 Nm

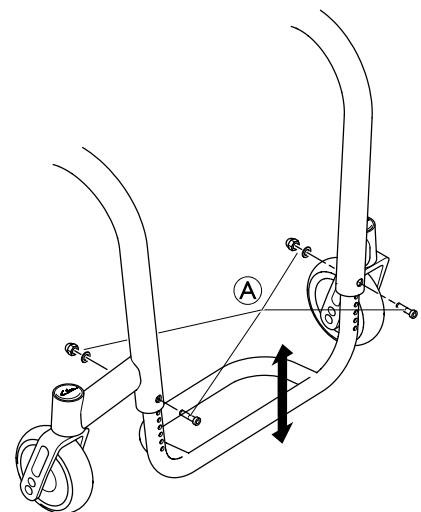



### Fitting and adjusting high-mounted footrest

Difficulty: ●○○

Tools: ● 4, 5, 8, 10

- 1 Fit the frame bar ④ for the high-mounted footrest to the front frame on both sides using the screw connections ①.
- 2 Fix the clamp set to both sides of the frame ③ using the screw connection ②. Only tighten lightly.
- 3 Slide the high-mounted footplate ⑤ into the clamp set and to the desired height.
- Tighten the screw connections ② on both sides.

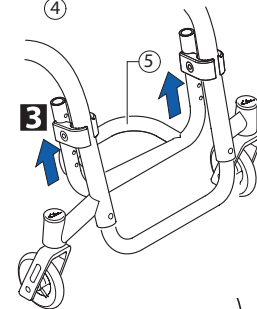
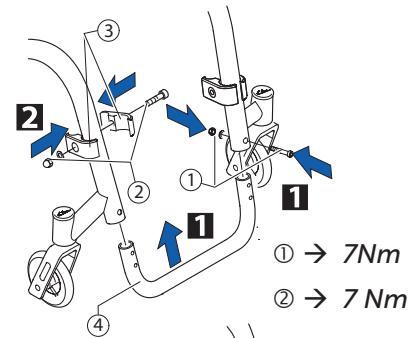

### Angle-adjustable footplate, adjusting the angle

Difficulty: ●○○

Tools: ● 4, 10

- To adjust the angle, release the four screw connections ① until the footplate can be moved.
- 1 Check and/or adjust the distance between the left and the right sides by pushing in or pulling out the tubes below the footplate in such a way that the bearings blocks are perpendicular to the ground.
- 2 Tilt the footplate into the desired position and tighten the screw connections ①.

The angle of the footplate must be set so that the user's feet cannot slide off the plate.

Make sure that the footplate has a minimum distance of 20 mm to the floor at its lowest point.

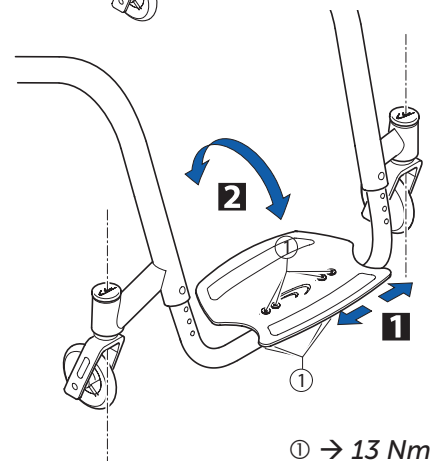



## SIDE PARTS

### Clothes-guard/mudguard

The clothes-guard fitted as standard can be replaced by a mudguard. Clothes-guard and mudguard are available in carbon.

<i>Clothes-guard size</i>		
	<i>Wheel size</i>	
<i>SHh</i>	<i>24"</i>	<i>25"</i>
430	L	-
440	L	L
450	L	L
460	M	L
470	M	M
480	-	M

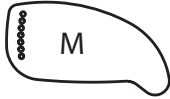
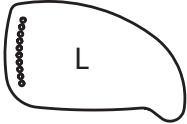
<i>Mudguard size</i>		
	<i>Wheel size</i>	
<i>SHh</i>	<i>24"</i>	<i>25"</i>
430	L	-
440	M	L
450	M	L
460	M	L
470	M	M
480	-	M

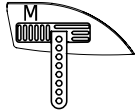
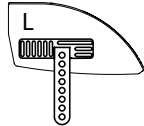

## Replacing the clothes-guard

Mounting element **A** must be mounted with parts **F**, **E**, **D** on the backrest tube **G**.

Difficulty: ●●○

Tools: ● 3, 4 ⬡ 8

- 1** If present, remove the clothes-guard to be replaced by loosening the screw connection **C**.
- Check the correct position of the clothes-guard **B** with fitted rear wheel. Here, find the suitable height on the clothes-guard for fixing the screw connection **C** to the backrest mounting element **A**.
- Gently tighten screw connection **C** until it slightly jams.
- Secure with grub screw **H**.
- 2** If necessary, the holder **I** on the seat module can be replaced by removing/fixing screw **J** with washer and cap nut **K**.

**i** The clothes-guard is correctly positioned if it can be inserted between the seat module and the holder and the upper edge runs above the rear wheel.

**K** → 7 Nm

**H** → 4 Nm

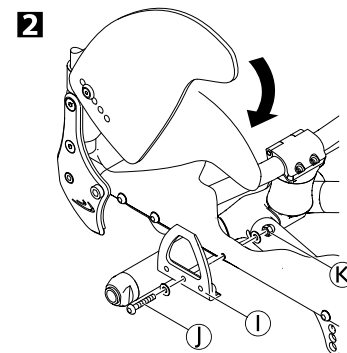
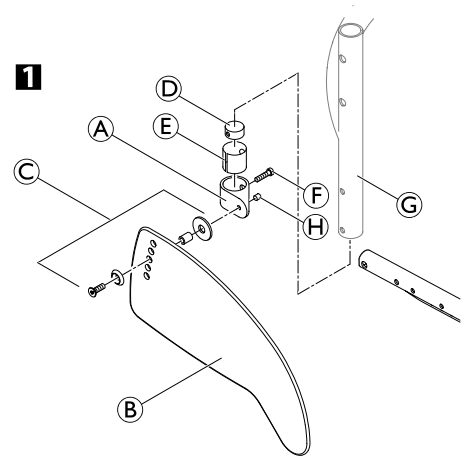

## Fitting the mudguard

Difficulty: ●●○

Tools: ● 3, 4 ⬡ 10 × 2

Remove the clothes-guard and the mounting elements on the backrest and the seat.

- 1** Fit the holder **B** to the seat module using the screw connections **A** and plate **C** and then refit the rear wheel.
- 2** Slightly loosen the grub screw **D** on the adjustment plate **E** and slide it along the mudguard carrier until the mudguard is at the desired height.
- The position of the mudguard can also be adjusted: Here, loosen the screw connections **F**, position the mudguard as required and tighten the screw connections **F** again.
- Tighten the grub screw **D** again.
- Carry out the same setting on both sides.
- By tightening or loosening the screws **G** you can adjust how easily the armrest can be pulled out or pushed in.

**i** If the wheelchair is equipped with a suspension, the distance between the mudguard and the wheel must be at least 40 mm.

**i** The existing axle may not be sufficiently long for the new configuration with mudguard. In this case, a longer axle must be fitted. → Changing the wheel chamber / fitting and adjusting an axle

**!** The distance between the mudguard and the wheel must be either < 8 mm or > 25 mm to prevent fingers from becoming caught between the wheel and the mudguard.

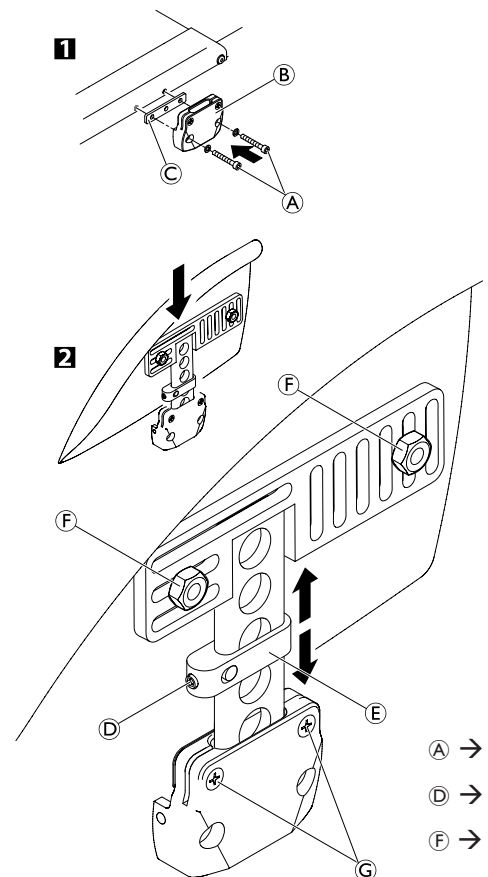

**A** → 7 Nm

**D** → 4 Nm

**F** → 7 Nm



## FRONT WHEELS

### Replacing a front wheel

Difficulty: ●○○

Tools: ● 2x3

- 1 Remove the screw ① with disk on one side. Remove the wheel axle ②.
- 2 Remove the front wheel ③.
- 3 Place the sleeves ④ between the new front wheel ③ and the fork.
- 3 Slide the axle ② through the fork, sleeves ④ and the front wheel ③ and fix the axle using the screw ①. Here, use the new screw supplied with the wheel as this screw comes with a thread-locking device.

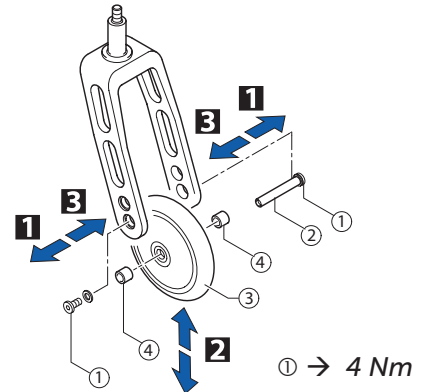

#### Function check:

The wheel may not wobble, but must rotate easily.

### Replacing a front wheel fork

Difficulty: ●●○

Tools: ☞ 10

- Remove the sealing cap ① of the bearings block by inserting two screwdrivers into the grooves and flipping it off.
- Remove the nut ② with the washer ⑤.
- Remove the front wheel fork ③.
- Check the ball bearings ④ and replace them if necessary.
- Insert the new front wheel fork with the washer ⑤ and the nut ② and tighten the nut.
- Carry out the function check (see below).
- Replace the sealing cap ①.

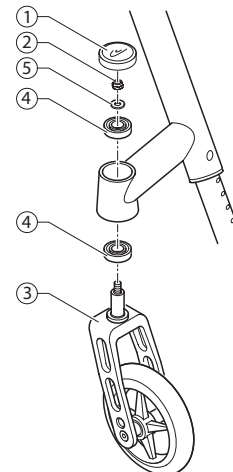

#### Function check:

Tip the wheelchair backwards by 90° so that it is lying on the backrest and the rear wheels. Turn the fork upwards (position A) and let it tip downwards.

The fork has been correctly adjusted if it easily turns to beyond the bottommost point and remains there (position B).

If the fork turns back to the lower position (position C), it has not been sufficiently tightened. There is a risk that the front wheels will start to wobble at high speeds.

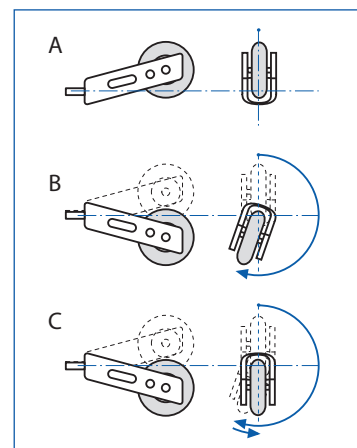



## REAR WHEELS

### Control of rear wheel parallelism

Difficulty: ●●●

Tool: ● 5

- Loosen the two bolts ④ that clamp the centrepart ③ to the axle ①.
- Rotate the axle tube to set the correct position.
- Tighten the two centrepart bolts ④, then replace the axle protection rings ② (if fitted).

**i** This adjustment must be carried out on a perfectly horizontal surface. The track of the rear wheel is correct if (measured at height of hub) the distance between the rear wheels is the same at the front and back ( $x=y$ ).

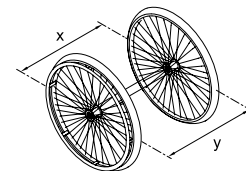
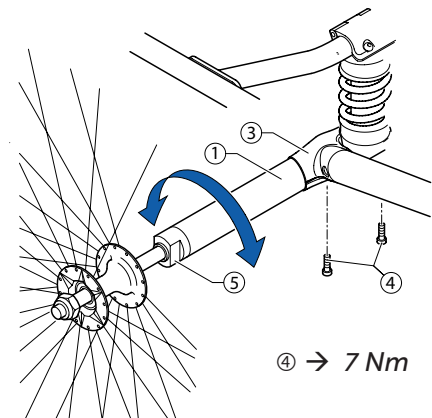
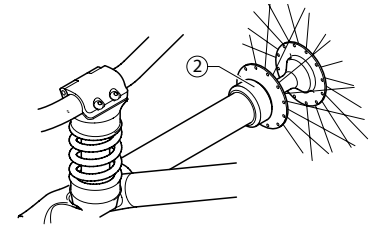

### Adjusting the removable axle

Difficulty: ●●○

Tools: — C 11, 19

- Remove the rear wheel.
- Hold the end of the removable axle ② using the straddle spanner.
- Adjust the length L of the removable axle by turning the nut ①. The length is correctly adjusted if the removable axle engages correctly when fixing the wheel and wheel has just minimal clearance.

**i** The wheels must be exchanged (left to right side and vice versa) after adjusting both removable axles. The adjustment must now be checked or carried out again to ensure the wheels can be switched.

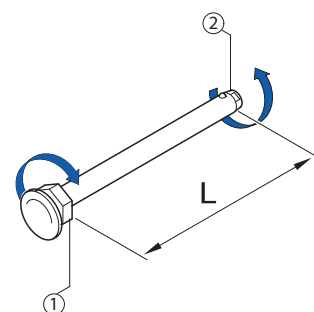



## Rear wheel axle replacement

A new axle has to be fitted if a different rear wheel camber is required.

Difficulty: ●●●

Tool: ● 5

- Remove the antitipper (if fitted), → Chap. Options and accessories; Antitipper assembly and adjustment.
- Remove the rear wheels and the axle protection rings ② (if fitted).
- Remove the two bolts ④ that clamp the centrepart ③ to the axle ①.
- Remove the axle ① by sliding it out of the centrepart ③.

**i** It may be necessary to gently prise the centrepart apart slightly with a boltdriver to remove or replace the axle without scratching it. This must be done very carefully to prevent cracking the coating of the centrepart.

- Slide the new axle ① into the centrepart ③. The centrepart must be approximately in the middle of the axle.
  - Loosely replace the two bolts ④, then replace the rear wheels.
  - Check that the axle is exactly in the middle by measuring the distance from the inside of the wheel to the edge of the seat module (distance A). Both sides must have the same measurement. If adjustment is necessary, slide the axle to the appropriate side.
  - Check that the rear wheel parallelism is correct by referring to control of rear wheel parallelism, → Chap. Rear wheels; Control of rear wheel parallelism.
  - Tighten the two centrepart bolts ④.
  - Replace the axle protection rings ② (if fitted)
- i** The bore of the axle protection ring is slightly larger at one end to make it easier to fit it to the end of the axle.
- Replace the antitipper (if fitted).

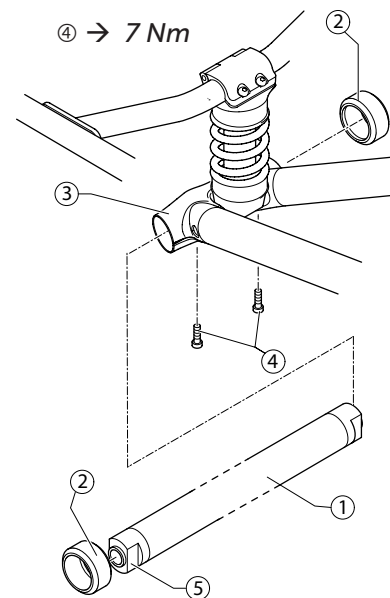
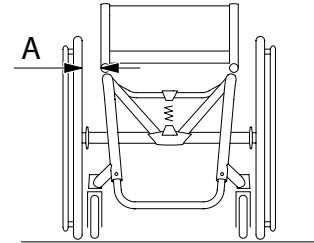





## BRAKES

### Parking brakes

#### Mounting the parking brake

Difficulty: ●●○

Tools: ● 5

- Position the brake holder ② around the front frame tube.
- Place the brake ③ in the brake holder.
- Screw the bolts ① into the brake assembly but do not tighten.
- Rotate the brake holder assembly around the frame tube to adjust the lateral distance of the brake.
- Rotate the brake in the brake holder to achieve a horizontal position of the brake rod ④ to the tire.
- Fully apply the brake and slide it towards the tire until the brake rod bears flush against the tire.
- Release the brake and slide it 3 mm backwards and tighten the bolts.

① → 13 Nm

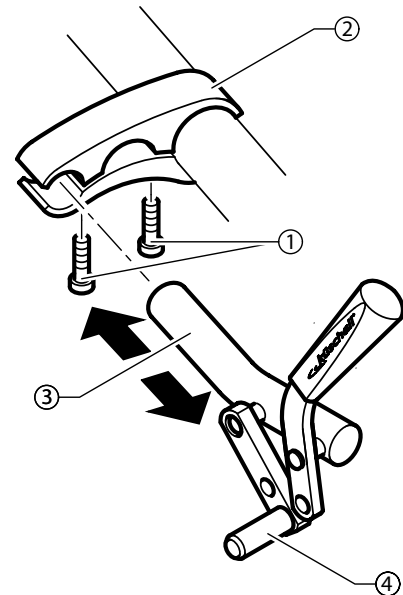

#### Adjusting the parking brake

Difficulty: ●○○

Tools: ● 5



#### WARNING!

The parking brakes must be readjusted whenever the rear wheels are replaced or the wheel chamber is changed.

The parking brake function is only guaranteed if the tire has the corresponding air pressure.

- Check the tire pressure in the rear wheels and correct if necessary.
- Slightly loosen bolts ① of the brake holder ②.
- Change the position of the brake assembly as described above.
- Tighten the bolt.



#### IMPORTANT!

The force to apply the brake must be 60 N (maximum).



Very little force is required for activating and deactivating the brake. If necessary, a brake lever extension can be mounted.

#### Visual check

Check that the parking brakes are positioned correctly. The brake is set correctly if the brake rod depresses the tire by no more than 4 mm when the brake is applied. (In the case of push/pull and standard brakes this will be the case when the brake shoe is approx. 25 mm away from the tire when released.)

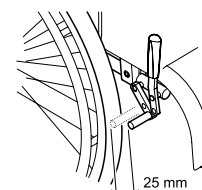

#### Function check

Place a weighted wheelchair with parking brake engaged facing uphill and then facing downhill on a ramp with an incline of 7°. The wheelchair must not move.



## OPTIONS & ACCESSORIES

### Antitipper assembly and adjustment

Difficulty: ●●●

Tool: ● 5

- 1 Remove the existing (short) pivot pin ① and replace with the longer pivot pin ②. (Please note that the pivot pin is secured with strong adhesive.)
- 2 Loosely assemble the 2 parts of the clamp ③ onto the axle with the bolts ④.
- 3 Slide the clamp ③ as close as possible to the centerpart ⑤ and onto the pivot pin ②.

The pivot pin must be fully engaged in the clamp to prevent the antitipper from turning on the axle.

- Tighten the bolts ④.
- Slide the antitipper ⑥ onto the clamp ③ and secure with the QuickPin ⑦.

#### Adjusting the height of the antitipper

- 2 The height of the antitipper ⑥ can be adjusted by pressing the spring pin ⑧ and sliding the inner part of the antitipper to the required position until the spring pin locates in the correct hole.

#### Function check:

The distance between the antitipper and the ground must be 40 - 60 mm. It must be easy to fold up the antitipper.

Tip the wheelchair backwards using the antitipper until the axle is perpendicular to the antitipper's point of contact with the ground. In this position, the distance between the rear wheel and the ground must be at least 50 mm.

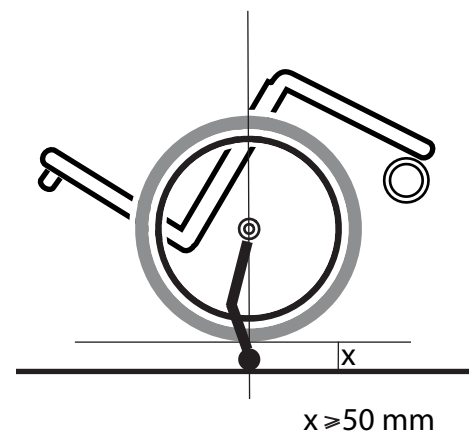
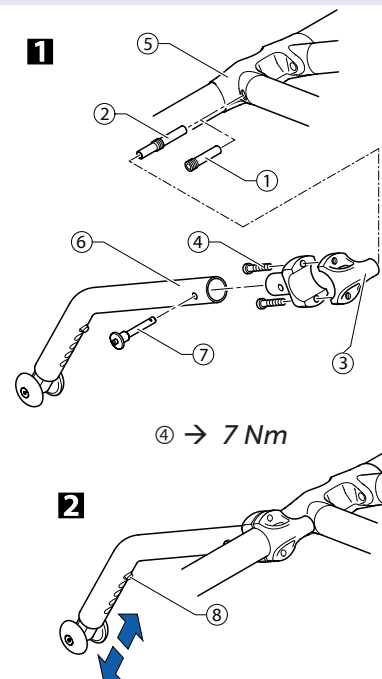

### Fitting the posture belt

Difficulty: ●○○

Tools: 10 mm

- Remove cap nut ① and washer ②.
- Attach the steel strap ③ to the backrest joint screw ④ using the supplied new cap nut ① and washer ②.

Ensure that the webbing of the posture belt is not twisted during assembly and the locking mechanism shows towards the front

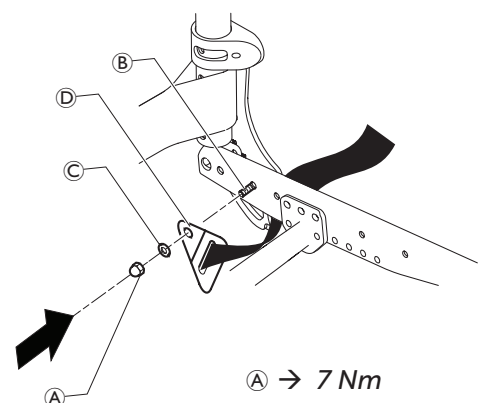





Küschall AG  
Benkenstrasse 260  
CH-4108 Witterswil  
kueschall@invacare.com  
www.kueschall.com

Service Manual  
KÜSCHALL R33  
ENGLISH | 2017-02

küschall<sup>®</sup> distributors

**Belgium & Luxemburg:** Invacare nv • Autobaan 22 • B-8210 Loppem

Tel: (32) (0)50 83 10 10 • Fax: (32) (0)50 83 10 11 • belgium@invacare.com • www.invacare.be

**Danmark:** Invacare A/S • Sdr. Ringvej 37 • DK-2605 Brøndby

Tel: (45) (0)36 90 00 00 • Fax: (45) (0)36 90 00 01 • denmark@invacare.com • www.invacare.dk

**Deutschland:** Invacare GmbH • Alemannenstraße 10 • D-88316 Isny

Tel: (49) (0)75 62 7 00 0 • Fax: (49) (0)75 62 7 00 66 • kontakt@invacare.com • www.invacare.de

**Eastern Europe, Middle East & CIS:** Invacare EU Export • Kleiststraße 49 • D-32457 Porta Westfalica

Tel: (49) (0)57 31 754 540 • Fax: (49) (0)57 31 754 541 • webinfo-eu-export@invacare.com • www.invacare-eu-export.com

**España:** Invacare SA • c/Areny s/n • Polígon Industrial de Celrà • E-17460 Celrà (Girona)

Tel: (34) (0)972 49 32 00 • Fax: (34) (0)972 49 32 20 • contactsp@invacare.com • www.invacare.es

**France:** Invacare Poirier SAS • Route de St Roch • F-37230 Fondettes

Tel: (33) (0)2 47 62 64 66 • Fax: (33) (0)2 47 42 12 24 • contactfr@invacare.com • www.invacare.fr

**Ireland:** Invacare Ireland Ltd • Unit 5 Seatown Business Campus • Seatown Road • Swords • County Dublin – Ireland

Tel : (353) 1 810 7084 • Fax: (353) 1 810 7085 • ireland@invacare.com • www.invacare.ie

**Italia:** Invacare Mecc San s.r.l. • Via dei Pini 62 • I-36016 Thiene (VI)

Tel: (39) 0445 38 00 59 • Fax: (39) 0445 38 00 34 • italia@invacare.com • www.invacare.it

**Nederland:** Invacare BV • Galvanistraat 14-3 • NL-6716 AE Ede

Tel: (31) (0)318 695 757 • Fax: (31) (0)318 695 758 • nederland@invacare.com • www.invacare.nl

**Norge:** Invacare AS • Grensesvingen 9 • Postboks 6230 • Etterstad • N-0603 Oslo

Tel: (47) (0)22 57 95 00 • Fax: (47) (0)22 57 95 01 • norway@invacare.com • island@invacare.com • www.invacare.no

**Österreich:** Invacare Austria GmbH • Herzog Odilostrasse 101 • A-5310 Mondsee

Tel.: (43) 6232 5535 0 • Fax.: (43) 6232 5535 4 • info@invacare-austria.com • www.invacare.at

**Portugal:** Invacare Lda • Rua Estrada Velha • 949 • P-4465-784 Leça do Balio

Tel: (351) (0)225 1059 46/47 • Fax: (351) (0)225 1057 39 • portugal@invacare.com • www.invacare.pt

**Sverige:** Invacare AB • Fagerstagatan 9 • S-163 91 Spånga

Tel: (46) (0)8 761 70 90 • Fax: (46) (0)8 761 81 08 • sweden@invacare.com • finland@invacare.com • www.invacare.se

**Suomi:** Camp Mobility • Patamäenkatu 5 • 33900 Tampere

Tel: 09-35076310 • info@campmobility.fi • www.campmobility.fi

**Schweiz/Suisse/Svizzera:** Invacare AG • Benkenstrasse 260 • CH-4108 Witterswil

Tel.: (41) (0)61 487 70 80 • Fax.: (41) (0)61 487 70 81 • switzerland@invacare.com • www.invacare.ch

**United Kingdom:** Invacare Limited • Pencoed Technology Park,

Pencoed, Bridgend CF35 5AQ • Switchboard Tel: (44) (0)1656 776 200, Fax: (44) (0)1656 776 201 •

Customer services Tel: (44) (0) 1656 776 222 • Fax: (44) (0) 1656 776 220 • UK@invacare.com • www.invacare.co.uk

**Australia:** Invacare Australia Pty Ltd • ABN 45 074 676 378, PO Box 5002, 1 Lenton Place, North Rocks, NSW 2151, Australia •

Freephone: 1800 069 042, Fax: 02 8839 5353 • E-mail: sales@invacare.com.au • Web: www.invacare.com.au

**New Zealand:** Invacare New Zealand • PO Box 62-124, 4 Westfield Place, Mt. Wellington, Auckland, New Zealand •

Freephone: 8000 468 222, Freefax: 0800 807 788 • E-mail: sales@invacare.co.nz • Web: www.invacare.co.nz