

KÜSCHALL COMPACT



©2018 Invacare Corporation

All rights reserved. Republication, duplication or modification in whole or in part is prohibited without prior written permission from Invacare Corporation. Trademarks are identified by TM and ®.

All trademarks are owned by or licensed to Invacare Corporation or its subsidiaries unless otherwise noted.



TABLE OF CONTENTS

GENERAL	5
Introduction	5
Spare parts and adaptations	5
Torque	6
Checks	6
Identifying and repairing faults	6
FRAME	7
Rear frame	8
Front frame	8
Retaining lever	8
Replacing the central cross-brace pivot bolt	9
Cutting the rear frame to length	9
SEAT	10
Seat height front (SHv)	10
Seat width (SB)	11
Seat depth (ST)	11
BACKREST	13
Backrest height	13
Angle-adjustable backrest	14
Replacing push handles / push handles and backrest	16
Replacing foldable push handles	18
Stabilisation bar	18
Backrest parts for adjustable backs with respect to backrest height	19
LEGRESTS	23
FOOTRESTS	24
One-piece footrest	24
Two-piece footrest	26
Two-piece footrest, angle-adjustable	26
SIDEPARTS	27
Clothes guard/mudguard	27
Installing the mudguard	27
Siderests	28
FRONT WHEELS	33
Front wheel fork	33
Special housing guides	34
REAR WHEELS	35
Adjusting the rear seat height	35
Tipping stability	35
Wheel camber	36
Adjusting the removable axle	36
Adapter plate for drum brake	37
Distance sleeves for rear wheels	37
Repairing or changing an inner tube	37
Repairing or changing a solid tire	37



BRAKES	38
Parking brakes	38
Drum brake	39
OPTIONS & ACCESSORIES.....	40
Antitipper	40
Tipper aid	41
Cane holder	41
Transit wheels	42
Mounting the posture belt	42
Attaching the snap hook symbols	43



GENERAL

Introduction

This Service Manual contains all the technical information necessary for the inspection, configuration or repair of a küschall® wheelchair.



WARNING!

Danger of accident and severe injuries.

If the wheelchair is improperly set it can cause accidents and severe injuries.

- Changes to the wheelchair may only be carried out by the dealer.

To maintain the necessary levels of safety and reliability, every wheelchair must be thoroughly examined once a year.

Some aspects of the assembly and configuration of the wheelchair require a high level of expertise. These assembly instructions therefore break the various tasks down into three categories:

Requirement	Symbol
Easy – technical understanding required	●○○
Medium – technical knowledge required	●●○
Difficult – technical knowledge and expertise in assembling wheelchairs required	●●●

The required tools and their sizes are listed before the instructions. The various torque values with which the nuts are to be tightened are also specified in the instructions. A torque spanner must be used, in order to comply with the specified torque values.

Tool	Symbol
Allen key	● 3, 4, 5
Torx wrench	* 10
Phillips head screwdriver	×
Open-end spanner	—C 8, 9, 10, 18
Socket spanner/Box spanner	◻ 8, 10, 19, 22

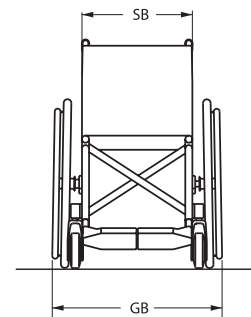
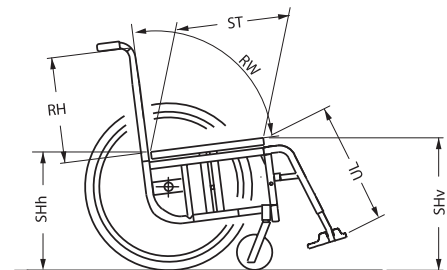

Spare parts and adaptations

All spare parts may be obtained from the Invacare Customer Service department. An electronic spare parts catalogue can be found at www.kuschall.com. Only original spare parts may be used. The written authorisation of Invacare Corporation must be obtained before installing additional adaptations on a küschall® wheelchair.



WARNING!

Some replacement parts are only available as a kit.

- Always use the complete new kit when replacing a part.

Fastening with hexagon socket bolts

Hexagon socket bolts are not designed to withstand an excessive application of force. When tightening or undoing a hexagon socket bolt, force should be applied to the nut wherever possible to avoid damaging the bolt.

Tightening and undoing

- Turn the nut using a socket spanner (only use an open-end spanner if there is insufficient space), using the Allen key simply to stop the bolt turning.

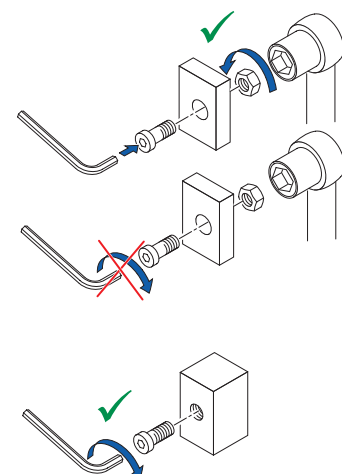



Tightening and undoing when no nut is present

If a hexagon socket bolt is screwed directly into a thread, the bolt must be tightened using the Allen key.

 Ensure that the Allen key is of good quality and not worn.

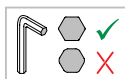

Torque

■ All bolts must be tightened with the torque specified in the following instructions.

Checks

Visual check

■ Check all components for cracks, especially the areas around joints and welded seams.

Checking bolts and screw connections

■ Check all bolts with the torques specified in the instructions regularly, and adjust if required.



CAUTION!

Several screw connections have been secured with thread locking adhesive. If these are opened, they must be secured again using new thread locking adhesive. Liquid high-strength and low-strength adhesives are available. For torque specifications it is pointed out whether an adhesive and which adhesive needs to be used.

Identifying and repairing faults

Fault	Possible cause	Action
The wheelchair does not travel in a straight line	Incorrect tyre pressure on one rear wheel	Correct tyre pressure
	One or more spokes broken	Replace broken spoke(s)
	Spokes tightened unevenly	Tighten loose spokes
	Front wheel bearings are dirty or damaged	Clean or replace the bearings
	Support bearings in forks faulty	Replace the support bearings
	Steering error or trail angle, left and right, uneven	Adjust steering error or trail angle
The wheelchair tips too easily	Rear wheels are mounted too far forwards	Mount the rear wheels further back
	Backrest angle too large	Reduce backrest angle
	Seat angle too large	Mount the adapter plate lower on the side profile
The brakes are gripping poorly or asymmetrically	Incorrect tyre pressure in one or both rear tyres	Correct tyre pressure
	Brake setting incorrect	Correct brake setting
The rolling resistance is very high	Tyre pressure in rear tyres is too low	Correct tyre pressure
	Rear wheels not parallel	Make rear wheels parallel
	Drum brake set too narrow	Set the drum brake
	Bearings are dirty or faulty	Replace the bearings
The front wheels wobble when moving fast	Too little tension on the clevis pin housing	Tighten the nut on the front wheel fork slightly
	Front wheel has worn smooth	Replace front wheel
The front wheel is stiff or stuck	Bearings are dirty or faulty	Replace the bearings
The wheelchair is very difficult to unfold	The backrest cover is too tight	Loosen the topmost hook and loop band of the backrest cover a little
Left and right side of the wheelchair can be moved in parallel to one another	Longitudinal stopping bolts on the seat edge are loose	Tighten the longitudinal stopping bolts on the seat edge



FRAME

- ① Rear frame
- ①a → 13 Nm
- ①b → 7 Nm
- ② Retaining lever
- ②a → 4 Nm
- ③ Cross
- ④ Front frame
- ④a → 13 Nm
- ④b → 7 Nm
- ④c → 7 Nm
- ⑤ Upper connecting tube
- ⑥ Lower connecting tube
- ⑦ Seat locking mechanism
- ⑧ Longitudinal stopping bolts

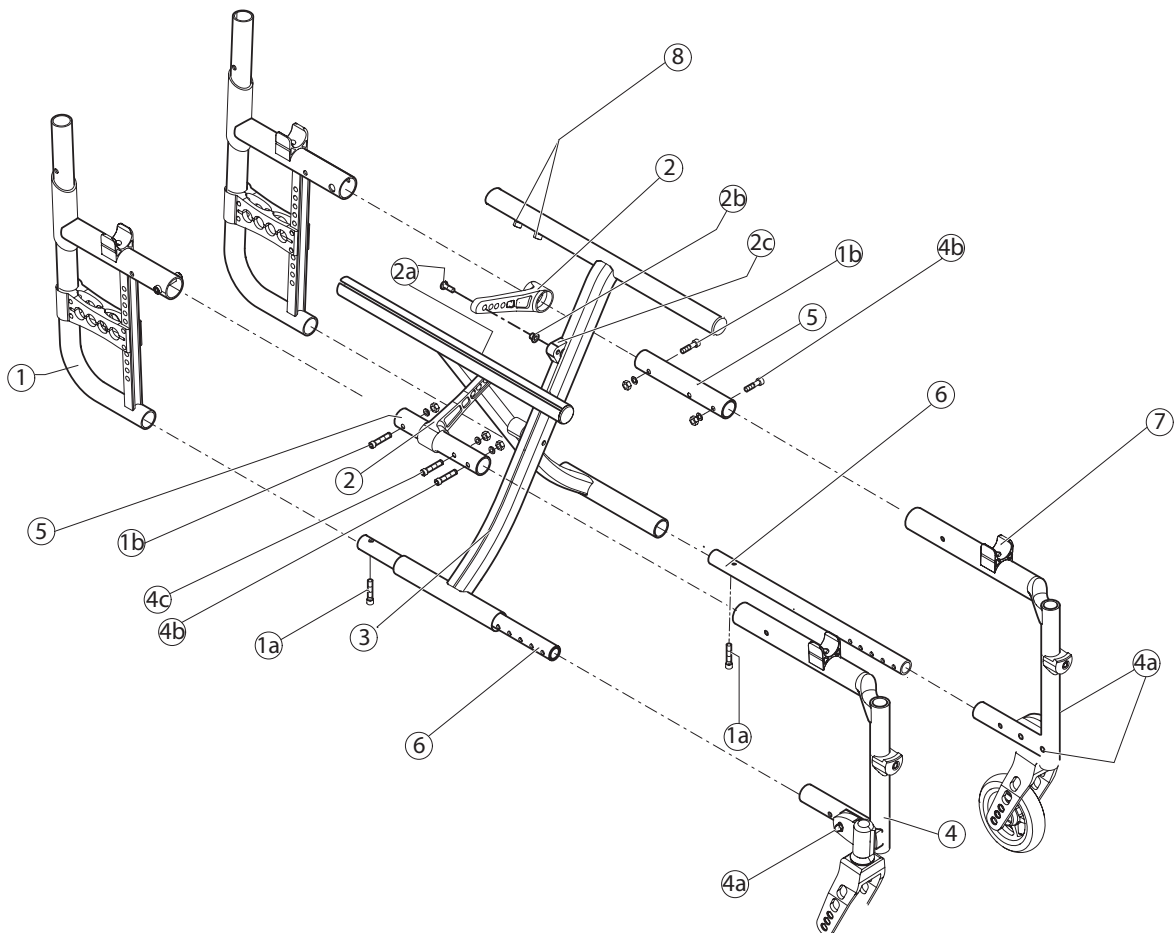
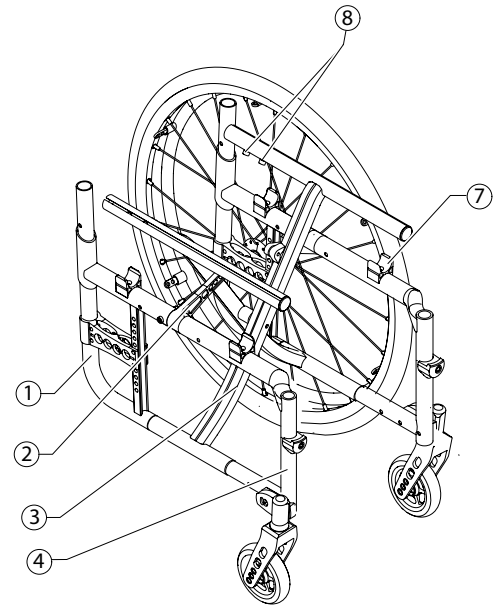



Rear frame

Replacing the rear frame

Difficulty: ●●○

Tools: ● 5 10

- Remove backrest.
- Loosen and remove bolts ①a and ①b.
- Pull out rear frame ① to the back.
- Push the rear frame onto the upper ⑤ and lower ⑥ connecting tubes.
- Reinsert and tighten bolts ①a and ①b.

Front frame

Replacing the front frame

Difficulty: ●●○

Tools: ● 3, 4, 5 10

- Disassemble brakes.
- Loosen and remove bolts ④a and ④b on both sides. (On abduction frames, the connecting tube ⑥ is welded onto the front frame; in this case loosen ①a and ④b.) If a flip to back side rest is fitted, also loosen ④c.
- Pull out front frame ④ to the front.
- Remove seat locking mechanism ⑦ with threaded insert from old front frame and fit it on the new front frame,
 - Chap. Seat; Turning the seat locking mechanism.
- Push the front frame onto the upper and lower connecting tube.
- Reinsert and tighten bolts ④a, ④b (if required ④c) on both sides.
- Set the front wheel fork angle,
 - Chap. Front wheels; Setting the steering error angle.

Retaining lever

Replacing the retaining lever

Difficulty: ●●○

Tools: ● 3, 4, 5 10

- With mudguard or clothes guard, fixed: remove ①a and ④b, with mudguard or side rest, insertable and siderest, foldable: remove ①a and ①b.
- Remove bolt ②a.
- Pull the retaining lever ② from the upper connecting tube ⑤.
- Remove sleeve ②b.
- Push the new retaining lever over the upper connecting tube ⑤.
- Position sleeve ②b with wide edge in joint ②c.
- Secure retaining lever with bolt ②a.
- With mudguard or clothes guard, fixed: reinsert and tighten bolts ①a and ④b, with mudguard or side rest, insertable and side rest, flip to back: reinsert and tighten bolts ①a and ①b.



Replacing the central cross-brace pivot bolt

! IMPORTANT!
It is recommended that the pivot bolt connection should be replaced when the central cross-brace is mounted with the old assembly kit.

The old assembly kit can be easily identified as follows:

- The spacer ② is not included.
- Nut ④ is not a cap nut.

Difficulty: ●●○

Tools: ● 5, ○ 10, Molykote TP42

- Remove the old bolt connection from the cross-brace.
- Lubricate both sides of distance part ⑤ slightly with Molykote TP42 and remove excess grease.
- Re-assemble the cross-brace using only the new assembly kit (SP1537689) containing bolt ① with washer, spacer ②, spring washer ③, safety cap nut ④ and distance part ⑤.

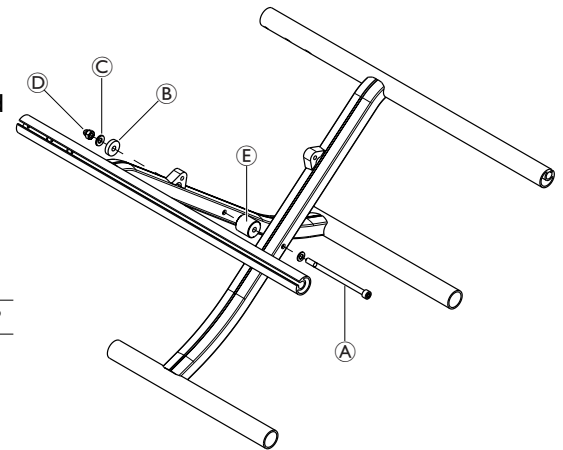

④ → 3 Nm (high-strength)

Cutting the rear frame to length

Difficulty: ●●○

Tools: Saw, cutting template, tube deburrer

- Referring to the table below, cut the rear frame to length measured from the lower edge of the back frame tube ①.
- Deburr the outer and inner cut edges at the back frame tube.
- Attach the plastic guide bushing ⑤ to the back frame tube and insert the telescopic tube ④.



WARNING!

Risk of breakage of the backrest.

- When mounting the telescopic tubes, always make sure that the uppermost hole ② of the telescopic tube is positioned at least 10 mm below the upper edge ③ of the rear frame tube.

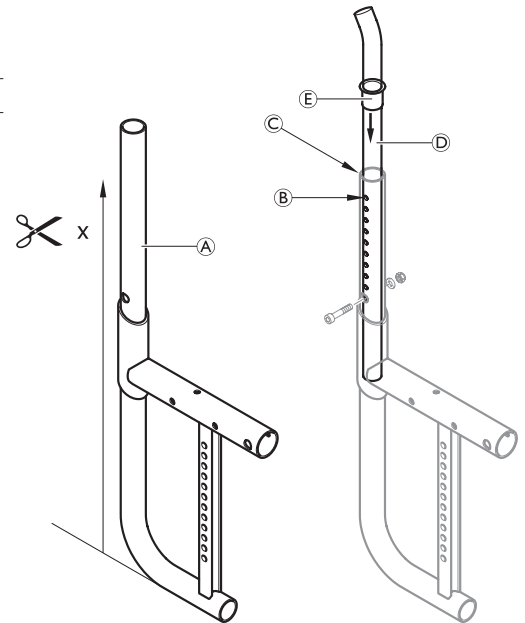

Rear frame - Cut off table in relation to backrest height and mounting type:

Backrest height (RH)		300	315	330	345	360	375	390	405	420	435	450	465	480	495	510
Standard/mini push handle																
lumbar	x [mm]	420	420	420	435	450	465	480	495	510	525	-	-	-	-	-
Without push handle																
lumbar	x [mm]	405	420	435	450	465	480	495	405	420	435	450	465	480	495	510
Foldable push handle																
lumbar	x [mm]	420	435	450	465	480	495	510	435	450	465	480	495	510	525	-
Height-adjustable push handle, rearset																
straight	x [mm]	405	420	435	450	465	480	495	510	525	-	-	-	-	-	-
lumbar	x [mm]	405	420	435	450	465	480	495	405	420	435	450	465	480	495	510
Height-adjustable push handle, integrated																
straight	x [mm]	390	405	405	405	405	405	405	420	435	450	465	480	495	435	450
lumbar	x [mm]	360	375	390	405	405	405	405	405	405	405	405	405	420	435	450



SEAT

Seat height front (SHv)

Options for changing the SHv:

- Replace front wheel with larger or smaller one or fit it at another position on the front wheel fork, → Chap. Front wheels, Replacing the front wheel.
- Replace front wheel fork with a larger or a smaller one, → Chap. Front wheels, Replacing the front wheel fork.
- Fit it high/low with the housing guide Hemi, → Chap. Front wheels, Special housing guides.

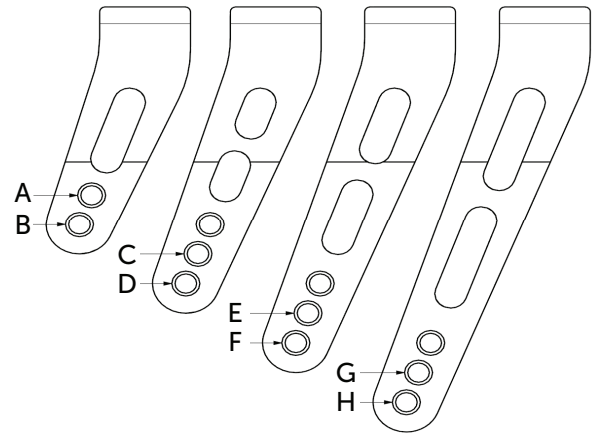

There are four front wheel fork sizes available.

<i>Seat height front with respect to fork size, front wheel size and mounting situation</i>															
Frame	high mounted					standard mounted					low mounted				
Front wheel	3"	4"	5"	6"	7"	3"	4"	5"	6"	7"	3"	4"	5"	6"	7"
SHv 380	A	-	-	-	-	-	-	-	-	-	-	-	-	-	-
SHv 390	B	-	-	-	-	-	-	-	-	-	-	-	-	-	-
SHv 400	B	-	-	-	-	-	-	-	-	-	-	-	-	-	-
SHv 410	C	B	-	-	-	A	-	-	-	-	-	-	-	-	-
SHv 420	D	C	-	-	-	B	-	-	-	-	-	-	-	-	-
SHv 430	E	C	C	-	-	B	-	-	-	-	-	-	-	-	-
SHv 440	F	D	C	-	-	C	B	-	-	-	A	-	-	-	-
SHv 450	G	E	D	-	-	D	C	-	-	-	B	-	-	-	-
SHv 460	H	F	E	D	-	E	C	C	-	-	B	-	-	-	-
SHv 470	-	G	F	E	-	F	D	C	-	-	C	B	-	-	-
SHv 480	-	H	G	F	E	G	E	D	-	-	D	C	-	-	-
SHv 490	-	-	H	G	F	H	F	E	D	-	E	C	C	-	-
SHv 500	-	-	-	H	G	-	G	F	E	-	F	D	C	-	-
SHv 510	-	-	-	-	H	-	H	G	F	E	G	E	D	-	-
SHv 520	-	-	-	-	-	-	-	H	G	F	H	F	E	D	-
SHv 530	-	-	-	-	-	-	-	-	H	G	-	G	F	E	-
SHv 540	-	-	-	-	-	-	-	-	-	H	-	H	G	F	E
SHv 550	-	-	-	-	-	-	-	-	-	-	-	-	H	G	F

6" and 7" front wheels cannot be used on the Ultra-Light dynamic frame (80°), if a 2-part angled footrest is fitted.



Seat height rear (SHh)

Options for changing the SHh:

- Replace rear wheel with a larger or a smaller one
- Change the position of the adapter plate, → Chap. Rear wheels.

<i>Seat height rear with respect to the rear wheels and positioning on the frame</i>						
<i>SHh [mm]</i>	<i>Rear wheel size [inch]</i>					
	<i>22"</i>	<i>24"</i>	<i>25"</i>	<i>26"</i>		
<i>370</i>	<i>1</i>				○	<i>1</i>
<i>380</i>	<i>2</i>				○	<i>2</i>
<i>390</i>	<i>3</i>	<i>1</i>			○	<i>3</i>
<i>400/410</i>	<i>4</i>	<i>2</i>	<i>1</i>		○	<i>4</i>
<i>420</i>	<i>5</i>	<i>3</i>	<i>2</i>	<i>1</i>	○	<i>5</i>
<i>430</i>	<i>6</i>	<i>4</i>	<i>3</i>	<i>2</i>	○	<i>6</i>
<i>440</i>	<i>7</i>	<i>5</i>	<i>4</i>	<i>3</i>	○	<i>7</i>
<i>450/460</i>	<i>8</i>	<i>6</i>	<i>5</i>	<i>4</i>	○	<i>8</i>
<i>470</i>	<i>9</i>	<i>7</i>	<i>6</i>	<i>5</i>	○	<i>9</i>
<i>480</i>	<i>10</i>	<i>8</i>	<i>7</i>	<i>6</i>	○	<i>10</i>
<i>490</i>		<i>9</i>	<i>8</i>	<i>7</i>	○	<i>11</i>
<i>500</i>		<i>10</i>	<i>9</i>	<i>8</i>	○	<i>12</i>

Seat width (SB)

SBs range from 280 - 500 mm.

Once the SB is specified, it is very difficult to change it: the cross struts, backrest cover (on standard backs) and, on some configurations, the footrests must be replaced.

Seat depth (ST)

STs range from 320 - 500 mm.

To reduce the ST, the cross struts must be shortened and a new appropriately sized seat cover fitted. At an ST \geq 400 mm, the frame can be shortened.

To enlarge the ST, new cross struts, a new appropriately sized seat cover and, depending on the ST, a new frame must be installed.



Replacing the seat cover

Difficulty: ●●○

Tool: ✱ 10

- 1 Loosen bolts ① and remove plug ②.
- 2 Remove seat cover including plastic rods.
- Position new seat cover. Adjust seat cover to width SB + 25 mm.
- Retighten bolts ① and plug ②.

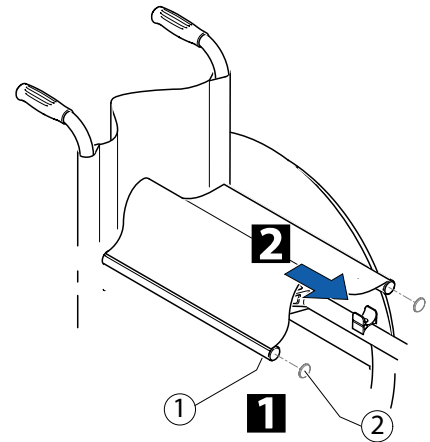

① → 4 Nm

Turning the seat locking mechanism

If the seat edge can be too easily removed from the seat locking mechanisms, either the front two or all four seat locking mechanisms can be rotated by 180°:

Difficulty: ●○○

Tool: ● 3

- Loosen bolt in seat locking mechanism ①.
 - Turn seat locking mechanism by 180°.
 - Secure bolt with adhesive (low-strength).
 - Retighten the bolt.
- i** Screw out the bolt only to the extent that the seat locking mechanism can be turned as otherwise the threaded insert can move and is then difficult to re-position.

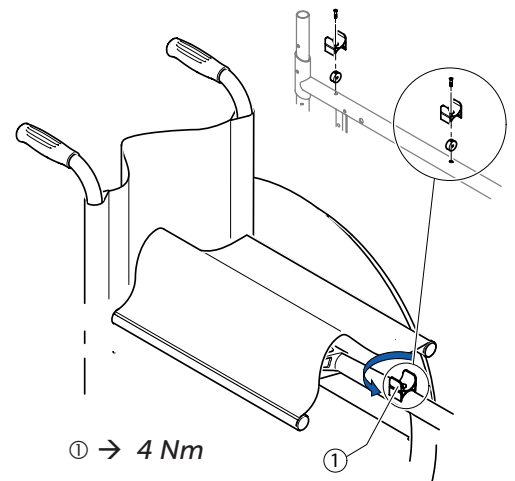

① → 4 Nm



BACKREST

Backrest height

The backrest height can be changed by fitting the telescopic tubes into another position in the backrest tubes. If this setting option is insufficient, the telescopic tubes can be replaced.

Adjusting the height of standard backrests

Difficulty: ●○○

Tools: ● 3, 4, 6 ○ 8, 10

- Push the backrest cover ① upwards and remove the bolt ② on both sides.
- Push the push handles ③ upwards or downwards until you reach the required height. Replace the bolt and tighten.

i If this setting range is insufficient, use new push handle tubes.

i If the backrest height was changed considerably, a new backrest cover may have to be fitted.

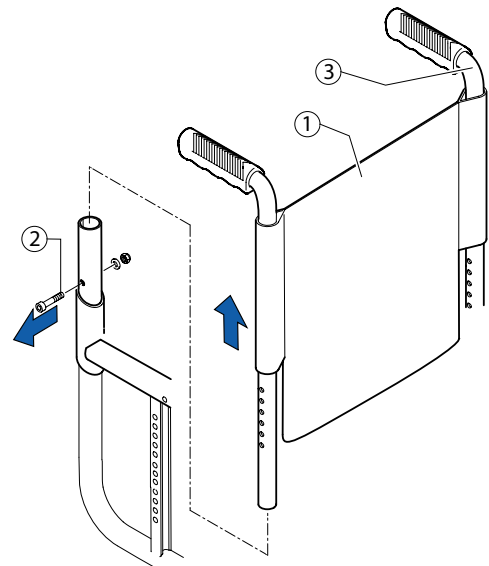

Adjusting the height of hook and loop adjustable backrests

Difficulty: ●○○

Tools: ● 3, 4, 6 ○ 8, 10

- Remove backrest cover and move the hook and loop bands until bolt ① is visible.
- Remove bolt ① and move the push handle tube to the required height.
- Insert bolt ① into the appropriate hole and tighten.

i If the backrest height is changed considerably, the push handles must be replaced. An additional hook and loop band may have to be fitted or one may have to be removed.

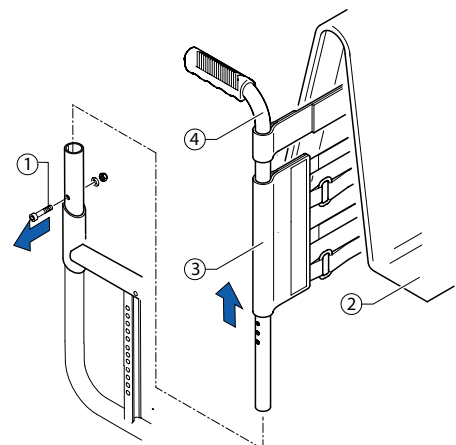



Angle-adjustable backrest

In order to make the backrest angle adjustable, an angle-adjustable backrest can be fitted.

Backrest angle

Position	Deviation from standard backrests	Angle between backrest and seat
1	12°	102°
2	8°	98°
3	4°	94°
4	0°	90°
5	-4°	86°
6	-8°	82°
7	-12°	78°

Fitting an angle-adjustable backrest

Difficulty: ●●○ Tools: ● 3, 4, 5 ◻ 8, 10 — C 10

Shorter rear frame (variant III) required.

- Push the lower joint pin ② into the rear frame ① and fix it using a bolt.
- Secure backrest tube ⑥ to the upper joint pin ③ using a bolt. Assemble the upper and lower joint pins ③ and ② and secure with bolt ④.
- Retighten the bolt ④.
- Set the desired backrest angle and secure in the nearest hole using bolt ⑤.
- Push the single hook and loop band ⑧ and then the other hook and loop bands ⑨ and end band ⑩ over the backrest tube ⑥.
- Push the push handle ⑦ into the telescopic tube ⑥ and fix at the required height.
- Secure end band ⑩ on the telescopic tube ⑦ with a bolt.

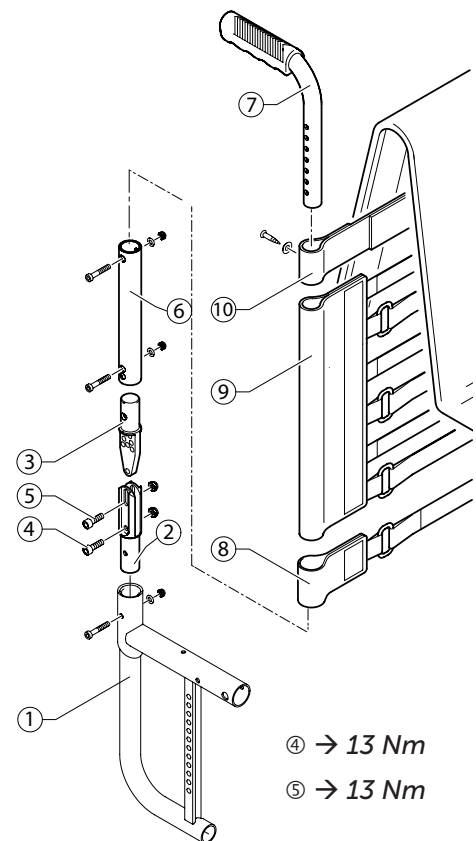



Setting the backrest angle

Difficulty: ●●○

Tools: ● 5 ○ 10 — C10

- 1 Remove the backrest cushion ② and push the hook and loop bands ③ upwards, until the backrest joint ① is invisible.
- 2 Remove the bolt ④.
- 3 Set the desired backrest angle, insert the bolts ④ in the nearest hole and tighten.
- Retighten the bolt ⑤.
- Perform the same setting on both sides.

Visual check

By looking from the side check that both backrest tubes are level and thus that the same angle has been set on both sides.

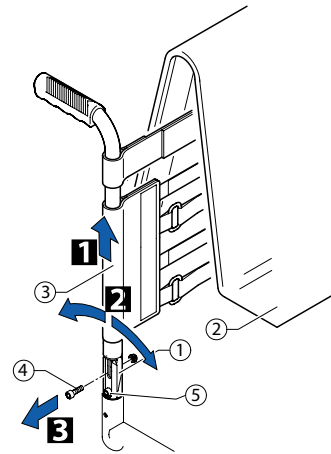

④ → 13 Nm

⑤ → 13 Nm

Fitting the joint for a folding backrest

Difficulty: ●●○

Tools: ● 4, 5 ○ 10

Shorter rear frame (variant III) required.

- 1 Set the desired backrest angle, insert bolt ① in the nearest position (Pos. 1, 2 or 3) and tighten. (With the curved backrest tubes, other positions can be achieved in addition to the 3 positions specified.)
- Fold down upper joint pin with intermediate backrest tube ②.
- 2 Push the joint housing ③ into the rear frame ④ and fit it using a bolt.

Backrest angle

Position 1 (rear position): 82°, with curved backrest tube 90°

Position 2 (mid position): 86°, with curved backrest tube 94°

Position 3 (front position): 90°, with curved backrest tube 98°

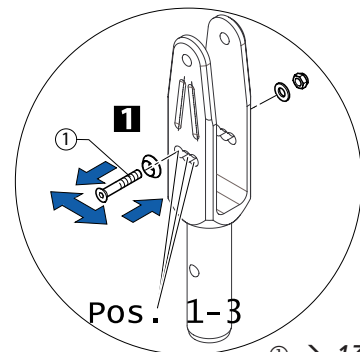

① → 13 Nm

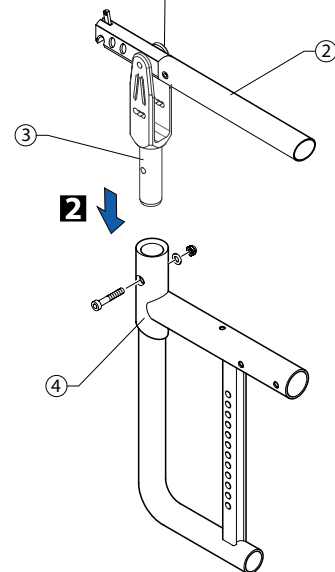



Replacing push handles / push handles and backrest

If the push handles are replaced with a different type of push handles, e.g. height-adjustable ones, it can happen that the rear frame must also be replaced.

Changing the backrest height can also mean that the configuration of the hook and loop bands must be changed.

Fitting standard push handles

Difficulty: ●●○

Tools: ✕ ● 3, 4, 5 ⬡ 8, 10

- 1 Secure the telescopic tube ④ to the rear frame ① at the required height.
- 2 Push the backrest bands ② and end band ③ onto the telescopic tube ④, end band first.
- 3 Secure end band ③ on the telescopic tube ④ with a bolt.

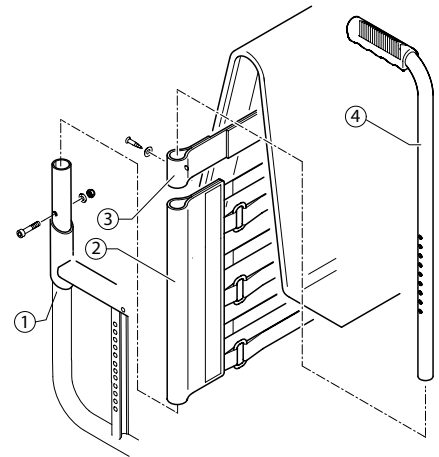

Fitting height adjustable integrated push handles

Difficulty: ●●○

Tools: ✕ ● 3, 4, 5 ⬡ 8, 10

Special rear frame required for RH 300 – 465 (variant II)

- Push lower telescopic tube ② and upper telescopic tube ③ into one another and insert bolt.
- Secure pre-assembled element (telescopic tubes ② and ③) at the required height on the rear frame ① with a bolt (7 Nm).
- Push the hook and loop bands ④ and end band ⑤ onto the telescopic tubes.
- Using the clamp bolt ⑦ secure the height adjustable push handles ⑥ through the telescopic tube ③.
- Push in push handle completely.
- Secure end band ⑤ on the telescopic tube ③ with a bolt.

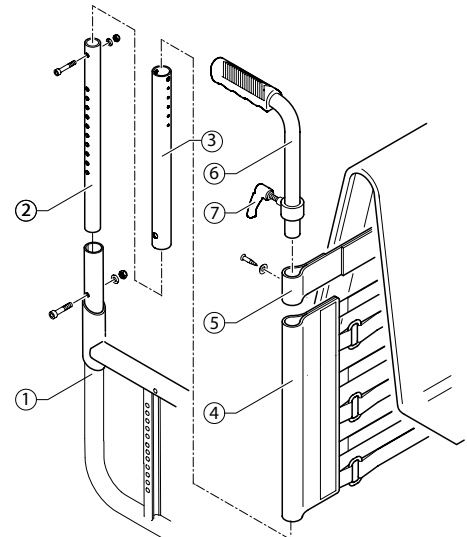



Fitting height adjustable, rear set push handles

Difficulty: ●●○

Tools: ✕ ● 3, 4, 5 ⬡ 8, 10

The hook and loop bands may have to be replaced with narrower ones, as space is required to secure the holder on the telescopic tube.

- Secure the telescopic tube ② to the rear frame ① at the required height.
- Press the cover cap ⑥ onto the end of the telescopic tube.
- Push the hook and loop bands ③ onto the telescopic tube.
- Push the holder ⑤ onto the telescopic tube and fix in place by tightening the clamp bolts.
- Fit end band ④ onto the telescopic tube and secure with a bolt.
- Attach protective cushion.

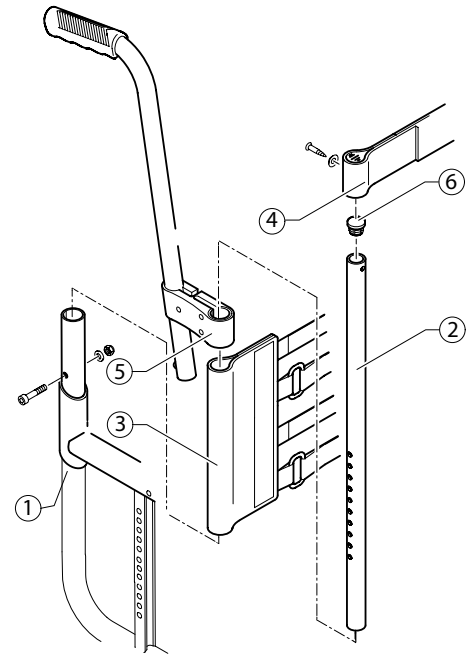

Fitting angle-adjustable backrest with height-adjustable push handles

Difficulty: ●●○

Tools: ✕ ● 3, 4, 5 ⬡ 8, 10 — C10

Shorter rear frame (variant III) required.

- Push the lower joint pin ② into the rear frame ① and fix it using the bolts.
- Fit backrest tube ⑥ onto the upper joint pin ③ using bolts. Assemble the upper and lower joint pins ③ and ② and secure with a bolt ④.
- Set the desired backrest angle and secure in the nearest hole using a nut and bolt ⑤.
- Retighten the bolt ④.
- Push the single hook and loop band ⑧ and then the other hook and loop bands ⑨ and end band ⑩ over the backrest tube ⑥.
- Push in push handle completely.
- Using the clamp bolt ⑪ fit the height-adjustable push handles ⑦ through the telescopic tube ⑥.
- Fit end band ⑩ onto the telescopic tube ⑥ with a bolt.

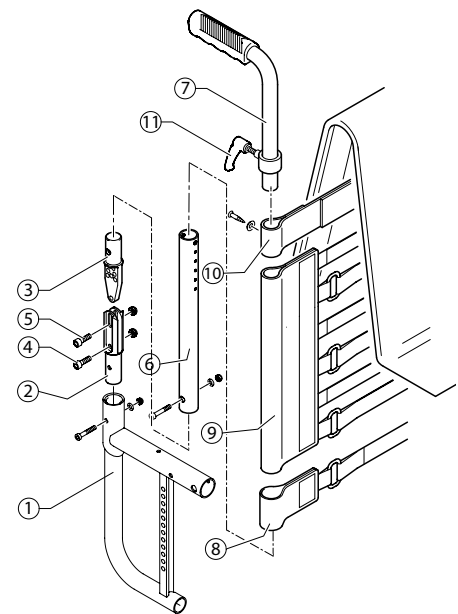

④ → 13 Nm

⑤ → 13 Nm



Replacing foldable push handles

Difficulty: ●○○

Tools: Hole punch pliers 6 mm, ● 3, 4

- Remove the old foldable push handle.
- Pull down the backrest cover (F) on the telescopic tube, until its hole (B) is uncovered.
- ! **IMPORTANT!**
Make sure that the threaded insert (E) (part no. 1580450) supplied with the new push handle is used for assembly.
- Place the threaded insert (E) in the telescopic tube.
- Punch a hole through the backrest cover with a distance of 10 mm from the upper edge, using hole punch pliers (see graphic below).
- Slide the new foldable push handle (A) onto the telescopic tube.
- Pull up the backrest cover, until it covers completely the rear hole in the push handle.
- Fix the foldable push handle with screw (C) and washer (G).
- Check screws (D) on both sides of the push handle and re-tighten if necessary.
- Carry out the same steps for the other push handle.

- ! **IMPORTANT!**
Make sure that the folding force is approximately 5 N (0.5 kg).
- ! **IMPORTANT!**
Fixing screw (C) may only be used once. Alternatively the screw can be cleaned (remove old thread locking adhesive) and reinstalled with new low-strength thread locking adhesive.

 The retrofit of foldable push handles requires new tubing.

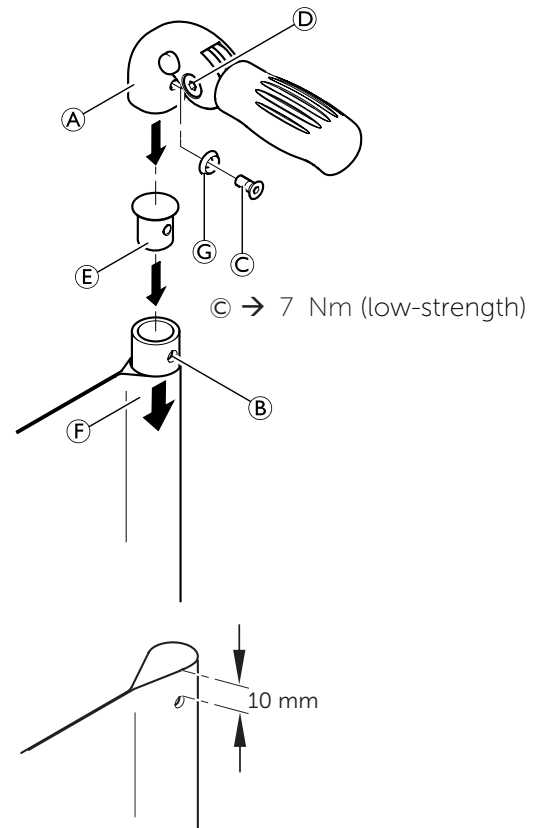

Stabilisation bar

Stabilisation bar assembly

Difficulty: ●●○

Tools: ● 3, 8 × 2

With a back height RH405 or larger it is possible to assemble a stabilisation bar to increase the rigidity of the backrest handles.

- Remove backrest cover (A), push handles (B) and 10 cm backrest band (or end band, if no push handles are assembled).
- Assemble a 5 cm backrest band (C) or end band with the screws (L) to the push handles (B).
- Assemble the push handles (B) with bolts and nuts (K).
- Attach the clamps (D) together with the RH socket (F) and the LH socket (H) with the screws (G) below the backrest band (C) to the push handles (B).
- Replace the push handle/backrest band/socket assembly.
- Press pin (E) and slide the stabilisation bar (J) into the RH socket (F) then swing the stabilisation bar upwards, press pin (I) and click the stabilisation bar into the LH socket (H).

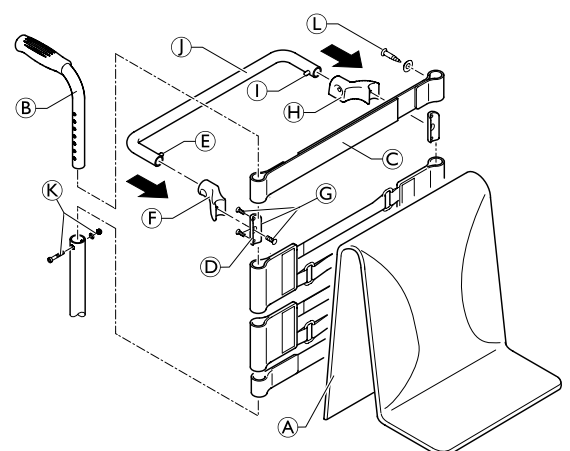

- G → 4 Nm
- K → 7 Nm
- L → 4 Nm



Backrest parts for adjustable backs with respect to backrest height

Fixed backrest with standard/mini pushhandles, foldable push handles* or without pushhandles:

Backrest height (RH) with respect to cover, backrest tubes, bands				
RH	Cover [ⓑ]	Telescopic tube [Ⓐ] (straight/lumbar)	Bands (without stabilizing bar, endband [ⓒ] = 10cm)	Bands (with stabilizing bar, endband [ⓒ] = 5cm)
300	S	S	1-band [ⓓ] + 2-band [ⓔ]	-
315	S	S	1-band + 2-band	-
330	S	S	2x2-band	-
345	M	S	2x2-band	-
360	M	S	2x2-band	-
375	M	S	1-band + 2x2-band	-
390	M	S	1-band + 2x2-band	-
405	M	M	1-band + 4-band [ⓕ]	1-band + 2x2-band
420	L	M	1-band + 4-band	2x1-band + 4-band
435	L	M	1-band + 4-band	2x1-band + 4-band
450	L	M	2-band + 4-band	2x1-band + 4-band
465	L	M	2-band + 4-band	1-band + 2-band + 4-band
480	L	M	2-band + 4-band	1-band + 2-band + 4-band
495	L	M	2-band + 4-band	1-band + 2-band + 4-band
510	L	M	1-band + 2-band + 4-band	1-band + 2-band + 4-band

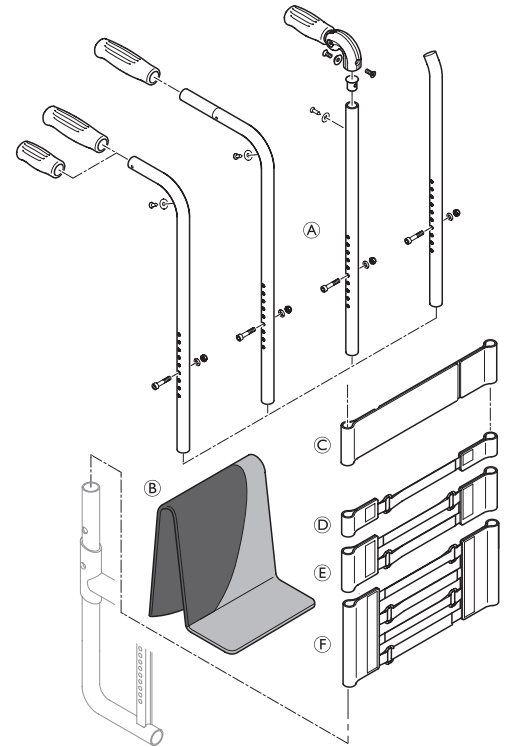

*Stabilization bar not possible for foldable push handles

Fixed or angle adjustable backrest with high adjustable push handles, rearset:

Backrest height (RH) with respect to cover, backrest tubes, bands				
RH	Cover [ⓑ]	Telescopic tube [Ⓐ]	Bands (without stabilizing bar, endband [ⓒ] = 10cm)	Bands (with stabilizing bar, endband [ⓒ] = 5cm)
300	S	L	2-band [ⓔ]	-
315	S	L	2-band	-
330	S	L	1-band [ⓓ] + 2-band	-
345	M	L	1-band + 2-band	-
360	M	L	1-band + 2-band	-
375	M	L	2x2-band	-
390	M	L/XL*	2x2-band	-
405	M	XL	4-band [ⓕ]	2x1-band + 2-band
420	L	XL	4-band	1-band + 4-band
435	L	XL	4-band	1-band + 4-band
450	L	XL	1-band + 4-band	1-band + 4-band
465	L	XL	1-band + 4-band	1-band + 4-band
480	L	XL	1-band + 4-band	2-band + 4-band
495	L	XL	1-band + 4-band	2-band + 4-band
510	L	XL	2-band + 4-band	2-band + 4-band

*Telescopic tube XL for angle adjustable backrest.

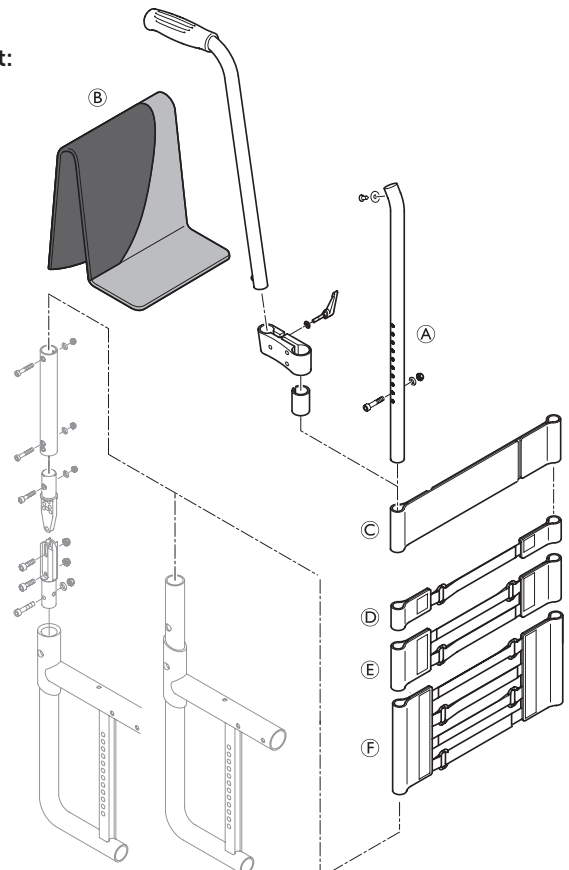



Fixed backrest with high adjustable push handles, integrated:

Backrest height (RH) with respect to cover, backrest tubes, bands*					
RH	Cover ©	Telescopic tube (straight)		Telescopic tube (lumbar)	
		Backrest tube ②	Push handle ①	Backrest tube ②	Push handle ①
300	S	S	S	S	S
315	S	S	S	S	S
330	S	S	S	S	S
345	M	S	S	S	S
360	M	S	S	S	S
375	M	S	L	S	S
390	M	S	L	S	S
405	M	S	L	M	S
420	L	S	L	M	S
435	L	S	L	M	L
450	L	S	L	M	L
465	L	S	L	M	L
480	L	S	L	M	L
495	L	M	L	M	L
510	L	M	L	M	L

*For bands configuration, see table „Fixed backrest with standard push handles“.

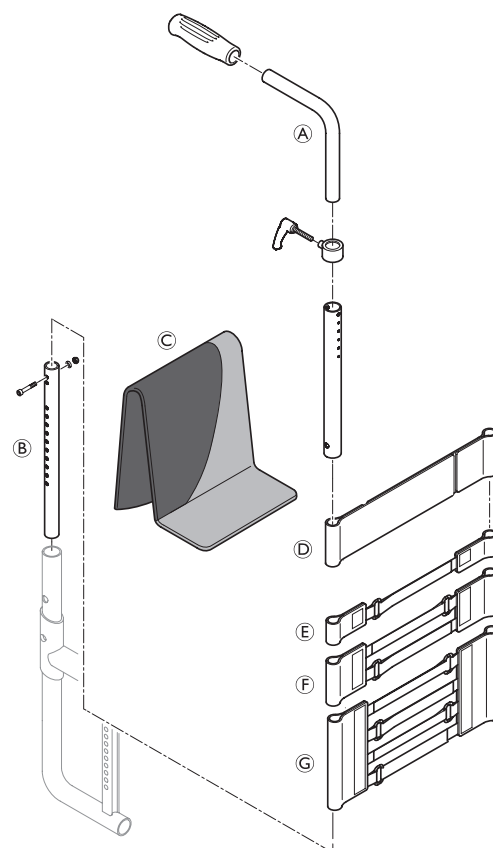

Angle adjustable backrest with standard/mini pushhandles, foldable push handles* or without pushhandles:

Backrest height (RH) with respect to cover, backrest tubes, bands				
RH	Cover ②	Telescopic tube ①	Bands (without stabilizing bar, endband © = 10cm)	Bands (with stabilizing bar, endband © = 5cm)
300	S	S	1-band ④ + 2-band ⑤	-
315	S	S	1-band + 2-band	-
330	S	S	2 x 2-band	-
345	M	S	2 x 2-band	-
360	M	S	2 x 2-band	-
375	M	S	1-band + 2x2-band	-
390	M	L	1-band + 2x2-band	-
405	M	L	1-band + 4-band ⑥	1-band + 4-band
420	L	L	1-band + 4-band	2-band + 4-band
435	L	L	1-band + 4-band	2-band + 4-band
450	L	L	2-band + 4-band	2-band + 4-band
465	L	L	2-band + 4-band	2-band + 4-band
480	L	L	2-band + 4-band	1-band + 2-band + 4-band
495	L	L	2-band + 4-band	1-band + 2-band + 4-band
510	L	L	1-band + 2-band + 4-band	1-band + 2-band + 4-band

* Stabilization bar not possible for foldable push handles

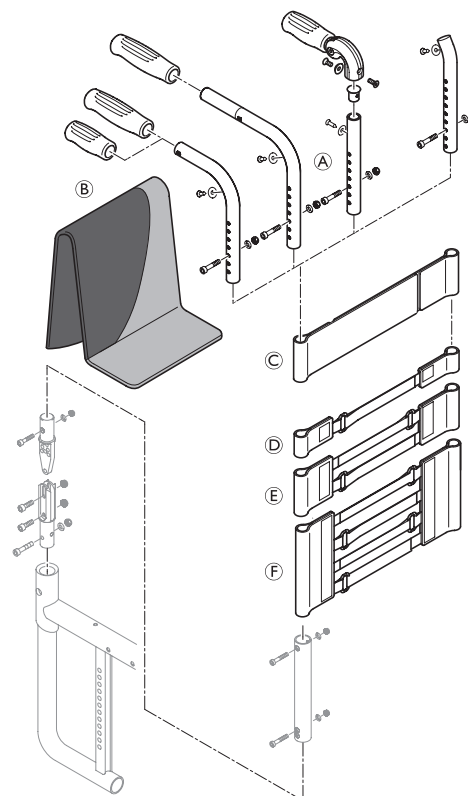



Angle adjustable backrest with high adjustable push handles, integrated:

Backrest height (RH) with respect to cover, backrest tubes, bands*			
Telescopic tube			
RH	Cover [©]	Backrest tube [®]	Push handle [Ⓐ]
300	S	S	S
315	S	S	S
330	S	S	S
345	M	M	L
360	M	M	L
375	M	M	L
390	M	M	L
405	M	M	L
420	L	L	L
435	L	L	L
450	L	L	L
465	L	L	L
480	L	L	L
495	L	XL	L
510	L	XL	L

* For bands configuration, see table „Angle adjustable backrest with standard push handles“.

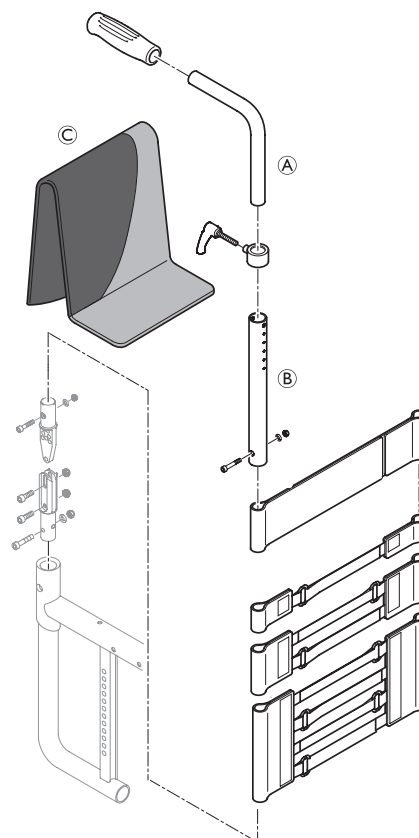

Foldable backrest with standard/mini pushhandles, foldable push handles¹⁾ or without pushhandles:

Backrest height (RH) with respect to cover, backrest tubes ²⁾ , bands				
RH	Cover [®]	Telescopic tube [Ⓐ]	Bands (without stabilizing bar, endband [©] = 10cm)	Bands (with stabilizing bar, endband [©] = 5cm)
300	-	-	-	-
315	-	-	-	-
330	-	-	-	-
345	M	S	2x1-band [Ⓓ]	-
360	M	S	2x1-band	-
375	M	S	1-band + 2-band [Ⓔ]	-
390	M	S	1-band + 2-band	-
405	M	S	1-band + 2-band	2x2-band
420	L	S	2x2-band	2x2-band
435	L	L	2x2-band	1-band + 2x2-band
450	L	L	2x2-band	1-band + 2x2-band
465	L	L	1-band + 2x2-band	1-band + 4-band
480	L	L	1-band + 2x2-band	1-band + 4-band
495	L	L	1-band + 4-band [Ⓕ]	1-band + 4-band
510	L	L	1-band + 4-band	3x2-band

¹⁾ Stabilization bar not possible for foldable push handles

²⁾ Backrest tubes lumbar possible from RH360

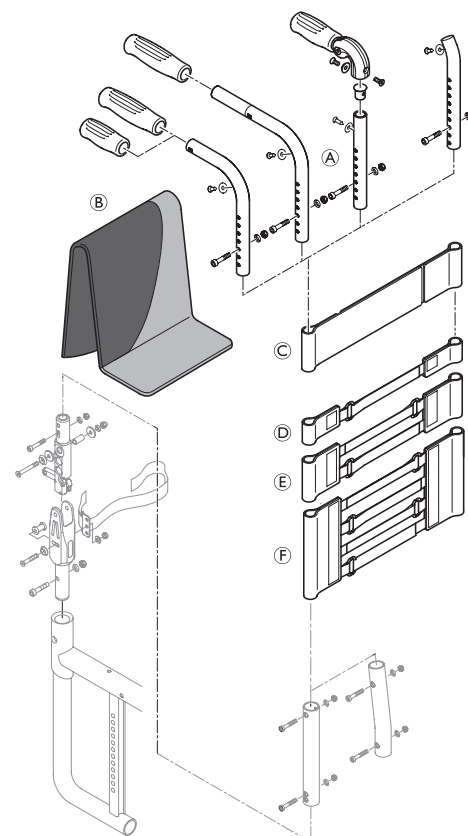



Foldable backrest with high adjustable push handles, rearset:

Backrest height (RH) with respect to cover, backrest tubes*, bands				
RH	Cover [Ⓑ]	Telescopic tube [Ⓐ]	Bands (without stabilizing bar, endband [Ⓒ] = 10cm)	Bands (with stabilizing bar, endband [Ⓒ] = 5cm)
300	-	-	-	-
315	-	-	-	-
330	-	-	-	-
345	M	S	2x1-band [Ⓓ]	-
360	M	S	2x1-band	-
375	M	S	2x1-band	-
390	M	S	2x1-band	-
405	M	S	1-band + 2-band [Ⓔ]	1-band + 2-band
420	L	S	1-band + 2-band	1-band + 2-band
435	L	L	1-band + 2-band	1-band + 2-band
450	L	L	2x2-band	2x2-band
465	L	L	2x2-band	2x2-band
480	L	L	2x2-band	2x2-band
495	L	L	1-band + 2x2-band	1-band + 2x2-band
510	L	L	1-band + 2x2-band	1-band + 2x2-band

* Backrest tubes lumbar possible from RH360

Foldable backrest with high adjustable push handles, integrated:

Backrest height (RH) with respect to cover, backrest tubes, bands*				
RH	Cover [Ⓒ]	Backrest tube [Ⓑ]	Push handle [Ⓐ]	
			Telescopic tube (82°,86°,90°)	Telescopic tube lumbar (94°,98°)
300	-	-	-	-
315	-	-	-	-
330	-	-	-	-
345	M	S	S	S
360	M	S	S	S
375	M	S	S	S
390	M	M	L	S
405	M	M	L	S
420	L	M	L	S
435	L	M	L	S
450	L	M	L	L
465	L	L	L	L
480	L	L	L	L
495	L	L	L	L
510	L	L	L	L

* For bands configuration, see table „Foldable backrest with standard push handles“.

For foldable backrests additionally a band is fixed close to the backrest joint. The band is of different length according to the seat width (SB): SB 280 - 360 → short / SB 380 - 440 → medium / SB 460 - 500 → long

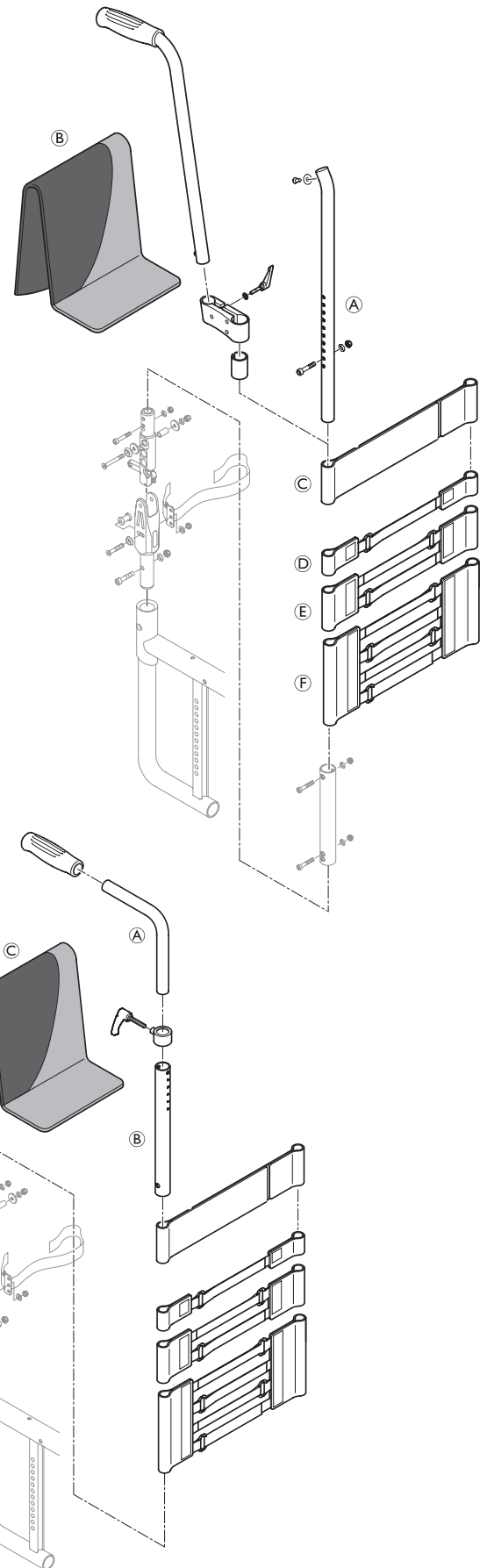



LEGRESTS

Legrests with angle measurements of 70, 80 and 90° are available.

Replacing the locking mechanism

Difficulty: ●○○

Tools: *10 ● 3

- Screw off unlocking lever ① manually.
- Remove hinge pin ②.
- Loosen bolts ④.
- Remove locking mechanism ③ and replace with a new one.
- Reinsert bolts ④ and tighten.
- Screw in the hinge pin ② again.
- Screw the unlocking lever ① back on manually.

Setting the locking lever

Difficulty: ●●○

Tools: ● 3, 5

It must be possible to move the unlocking lever ① 1-2 mm freely forward and back, without having to move the bolt ⑤. This guarantees that the bolt is sitting optimally in the counterpiece ⑥. If this free mobility is greater or smaller than specified, the unlocking lever must be reset:

- Screw off the unlocking lever ① manually.
- Loosen the hinge pin ② (do not remove).
- Screw bolt ⑤ in deeper to reduce movement or screw bolt ⑤ further out to increase movement.
- Set it so that the pin can move freely by 1-2 mm.
- Retighten the hinge pin ② again.
- Screw the unlocking lever ① back on manually.

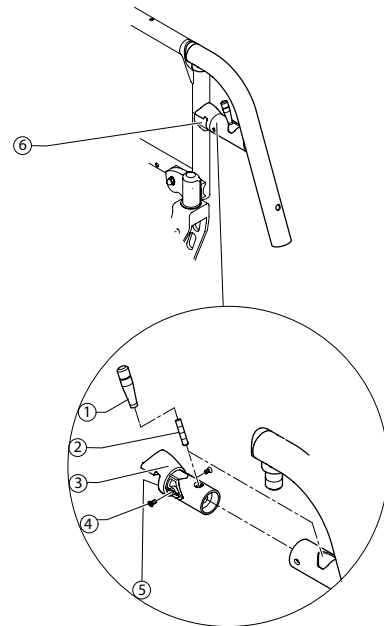

② → 3 Nm

④ → 3 Nm



FOOTRESTS

One-piece and two-piece footrests are available.

One-piece footrest

Replacing the footplate

Difficulty: ●○○

Tools: ● 4 ○ 10

- Loosen bolts ① on both sides.
- Remove footplate ② and replace with a new one.
- Re-insert bolts ① and tighten.

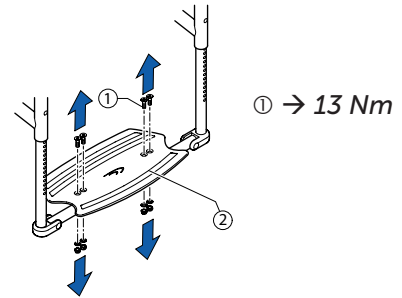

Disassembling/fitting the footrest

Difficulty: ●○○

Tools: ● 4 ○ 8

- 1 Remove bolts ① on both sides.
- 2 Pull out the footrest.
- 3 Insert new footrest.
- 4 Tighten bolts ① on both sides at the same height and in the required position.

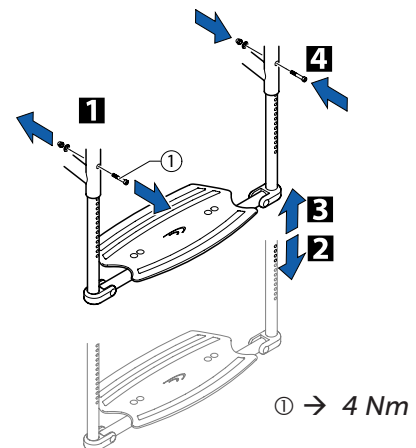

Adjusting the height of the footrest

Difficulty: ●○○

Tools: ● 4 ○ 8

- 1 Remove bolts ① on both sides.
- 2 Hold the telescopic tubes ② with both hands and push the footrest into the required position.
- 3 Insert bolts ① into the nearest hole on both sides and at the same height and tighten securely.

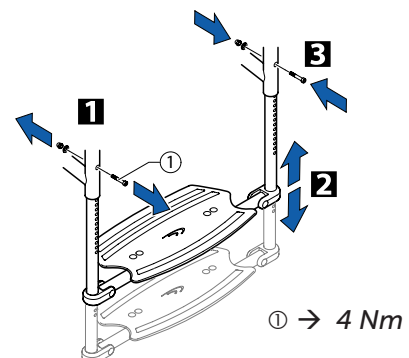



Centring and adjusting the angle

Difficulty: ●○○

Tools: ● 4 ○ 10

- Loosen bolts ① and ② slightly.
- 1 Set the same distance from the side tube to the footplate on both sides.
- 2 Set the required footplate incline.
- Re-tighten bolts ① (fixed side of the footplate).
- Turn the little tube ③ on the moving side of the footplate such that it engages properly.
- Tighten bolts ②.

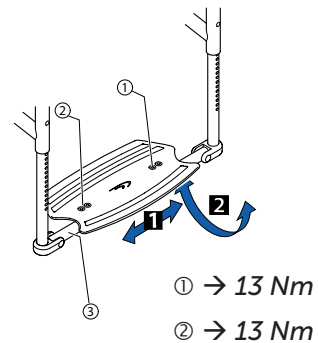

Changing the position of the footrest (set to rear – set to front)

Difficulty: ●○○

Tools: ● 4 ○ 10

- 1 Loosen bolts ① on both sides and remove.
- 2 Turn the footplate with the clamp component.
- 3 Re-insert bolts ① and tighten.

① → 13 Nm

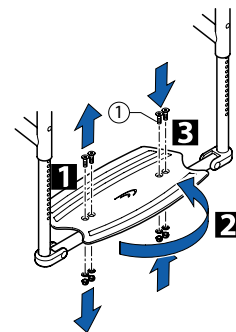



Two-piece footrest

Difficulty: ●○○

Tools: ● 4 ◻ 8

Disassembling/fitting footrests

- 1 Remove bolts ① on both sides.
- 2 Pull out footrests.
- 3 Push the new footplates into the frame and at the required height.
- 4 Insert bolts ① into the nearest hole on both sides and at the required height and tighten.

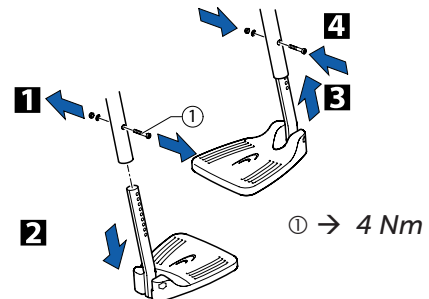

Adjusting the height of the footrests

Difficulty: ●○○

Tools: ● 4, ◻ 8

- Remove bolts ①.
- Push the footplates into the required position.
- Insert bolts ① into the nearest hole on both sides and at the required height and tighten.

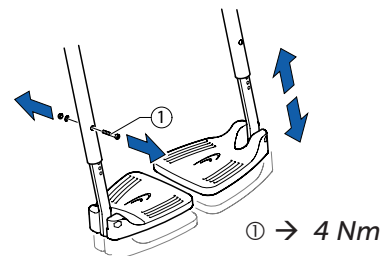

Changing the position of the footrests (set to rear – set to front)

Difficulty: ●○○

Tool: ● 5

- 1 Remove bolts ①.
- 2 Pull the footrests away downwards and replace.
- 3 Re-insert bolts ① and tighten.

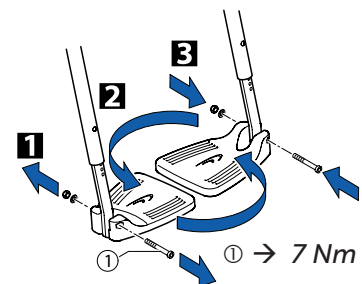

Two-piece footrest, angle-adjustable

Adjusting the angle

Difficulty: ●○○

Tool: ● 5

- 1 Loosen bolt ①.
- 2 Change the angle of the footrest until it reaches the required position.
- Retighten bolt ①.

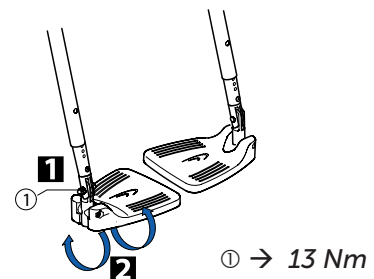



SIDEPARTS

Clothes guard/mudguard

Fitting the clothes guard/mudguard

Difficulty: ●●○

Tools: ● 3 ○ 8

- 1 Fit side fastenings ① onto the frame.
- 2 Fit clothes guard/mudguard ② with bolts and nuts onto the side fastenings (4 Nm).



CAUTION!

Fit the mudguard such that it is positioned either < 8 mm or > 25 mm above the tyres, to avoid the risk of trapping one's fingers.

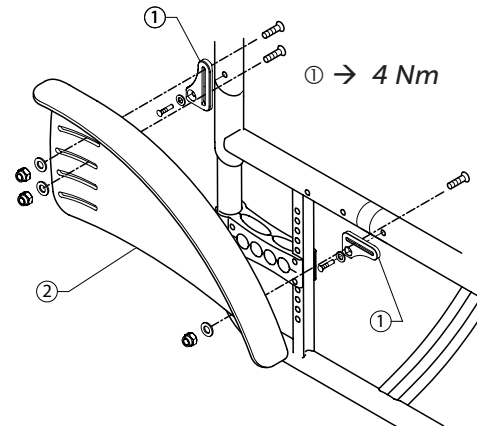

Adjusting the clothes guard/mudguard

Difficulty: ●●○

Tools: ● 3 ○ 8

- 1 Loosen bolts ①. Move the clothes guard/mudguard ②.
- Retighten bolts ①.
- or
- 2 Loosen and remove bolts ①.
- 3 Re-fit clothes guard/mudguard ② in another position.

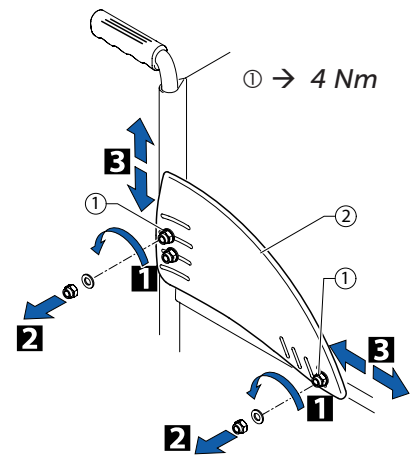

Installing the mudguard

Difficulty: ●●○

Tools: ● 3, 4 ○ 10 × 2

Remove the clothes-guard and the mounting elements on the backrest and the seat.

- 1 Install the holder ③ to the frame using the screw connections ④ and ⑤ and then refit the rear wheel.
- 2 Slightly loosen the grub screw ⑥ on the adjustment plate ⑦ and slide it along the mudguard carrier until the mudguard is at the desired height.
- The position of the mudguard can also be adjusted: Here, loosen the screw connections ⑧, position the mudguard as required and tighten the screw connections ⑧ again.
- Tighten the grub screw ⑥ again.
- Carry out the same setting on both sides.
- By tightening or loosening the screws ④ you can adjust how easily the mudguard can be pulled out or pushed in.



The existing axle may not be sufficiently long for the new configuration with mudguard. In this case, a longer axle must be fitted. → Changing the wheel camber / fitting and adjusting an axle



The distance between the mudguard and the wheel must be either < 8 mm or > 25 mm to prevent fingers from becoming caught between the wheel and the mudguard.

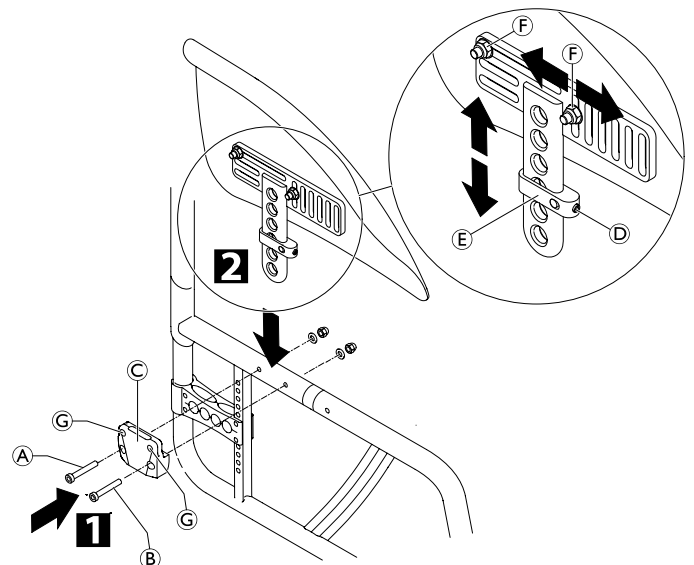

④ → 4 Nm

⑤ → 7 Nm

⑥ → 4 Nm

⑧ → 7 Nm



Siderests

In general a torque of 7 Nm is used to fit the side rests.

Fitting a flip to back side rest in the frame colour

Difficulty: ●●○

Tools: ● 3, 4, 5 ◻ 10

- Fit the side fastening element with bolt ①a .
- For bolt ①b, bore a hole with a diameter of 6 mm through the front frame (hole already made in the connecting tube) and fit bolt ①b.
- Screw the sleeve and bolt ② onto the rear fastening element ③.
- Fit rear fastening element ③ and clip ⑦ loosely with bolts ⑧ and sleeves ⑨ (normal rear frame: 17 mm beneath the upper edge of the frame reinforcement, on a shortened rear frame, directly flush with the upper edge of the frame reinforcement).
- Mount the side rest ④, position rear fastening element ③ precisely.
- Attach the wedge ⑤ and headless bolt ⑥.

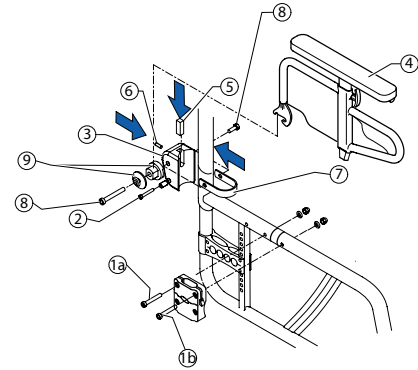

 The sleeves ⑨ are different for flip to back side rest in frame colour and flip to back side rest with engagement mechanism.

 To enlarge the distance between the wheels additionally, a different adapter sleeve, which is mounted from the inside, has to be applied.

Fitting flip to back side rest with locking mechanism

Difficulty: ●●○

Tools: ● 3, 4, 5 ◻ 10

- Fit the side fastening element with bolt ①a .
- For bolt ①b, bore a hole with a diameter of 6 mm through the front frame (hole already made in the connecting tube) and fit bolt ①b.
- Screw the sleeve and bolt ② onto the rear fastening element ③.
- Fit rear fastening element ③ and clip ⑦ loosely with bolts ⑧ and sleeves ⑨ (normal rear frame: 17 mm beneath the upper edge of the frame reinforcement, on a shortened rear frame, directly flush with the upper edge of the frame reinforcement).
- Mount side rest ④, position rear fastening element ③ precisely.
- Attach the wedge ⑤ and headless bolt ⑥.

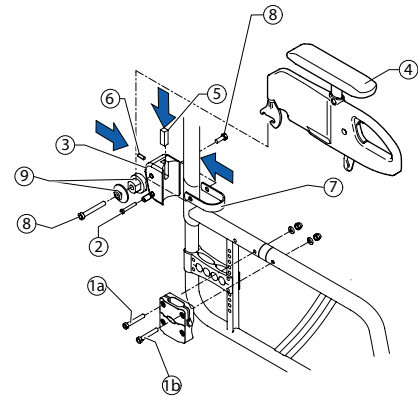

 The sleeves ⑨ are different for flip to back side rest in frame colour and flip to back side rest with engagement mechanism.

 To enlarge the distance between the wheels additionally, a different adapter sleeve, which is mounted from the inside, has to be applied.



Fitting the küschall armrest

Mounting the armrest hardware

Difficulty: ●●●

Tools: ● 3, 4, 5 □ 10

- Insert nuts **C** and bolts **B** into the upper holes of the armrest holder **A** and carefully tighten. Do not squeeze the holder.
- Mount the armrest holder **A** to the rear frame hole **M** using bolt **F**, sleeve **E**, washer and nut **D**.
- Drill holes **N** with a diameter of 6 mm through the front frame by inserting the drill bit through the free hole of the pre-mounted armrest holder **A**.
- Insert bolt **H** and tighten with washer and nut **G**.
- Grease the pin **P** and Insert it with the spring **O** into the inner hole of clamping part **K** and place it around the reinforced part **L** of the rear frame.
- Place the mating clamping part **J** around the rear frame and fix in true alignment with washers and bolts **I**.

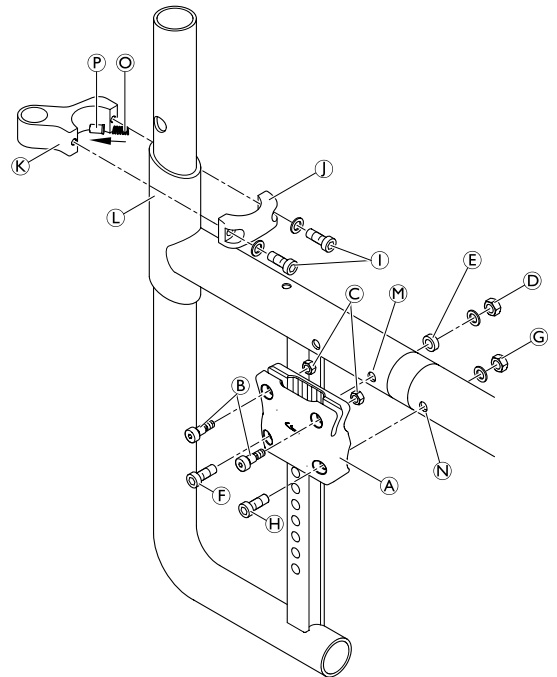

Installing/Removing the armrest, T-armrest pad and cover

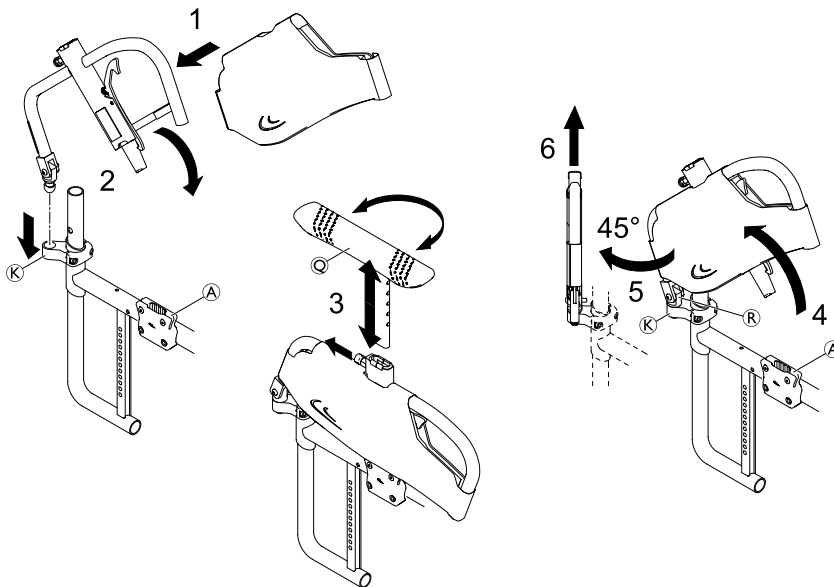

D → 7 Nm

G → 7 Nm

I → 4 Nm

Installing

- 1** Install the armrest cover to the armrest assembly.
- 2** Insert the armrest assembly into the joint **K** and swivel it downwards so that it engages into the armrest holder **A**.
- 3** Install the T-armrest pad **Q** to the armrest assembly.

Removing

- 3** Remove the T-armrest pad from the armrest assembly.
- 4** Swivel the armrest assembly upwards out of the armrest holder **A**.
- I** On the backside of the joint pin **R** there is a tapped hole with a M5 stop screw **S** to define the stop of the armrest assembly when swivelling backwards. Adjust the stop screw as required.
- 5** Swivel the armrest assembly 45° outwards.
- 6** Lift the armrest assembly out of joint **K**.

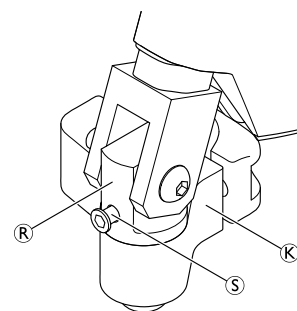



Fitting side rest insertable, continuously height-adjustable

Difficulty: ●●○

Tools: ● 4, 5 ◻ 10

- 1 Fit the side fastening element (A) with bolts (B) and (C).
- 2 Insert side rest into the fastening element.

Adjusting the height

- Slightly loosen the grub screw (D) on the adjustment plate (E) and slide it along the armrest carrier until the armrest is at the desired height.
- Retighten the grub screw (D).

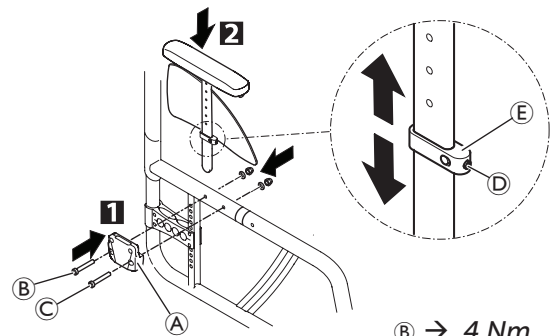

B → 4 Nm

C → 7 Nm

D → 4 Nm

Fitting a simple swivelling armrest

Difficulty: ●●○

Tools: ● 4, 5

- 1 Fit the rear fastening element.
 - 2 Insert the armrest.
- Adjust height by adjusting the bolt in the tube of the armrest.

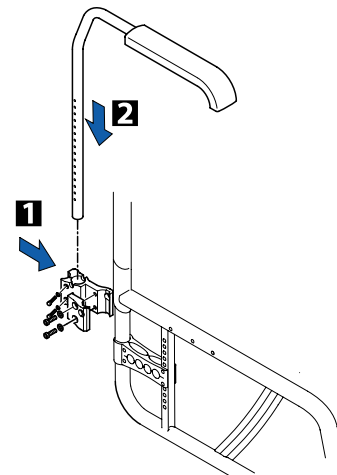



Size of the clothes guard/mudguard

The clothes guard and mudguard can be adjusted to suit the height of the rear wheel exactly. Two sizes of each are available. For the removable carbon mudguard there is an additional size (XL) for the two smallest rear seat heights (SHh).

Clothes guard mounted fix:

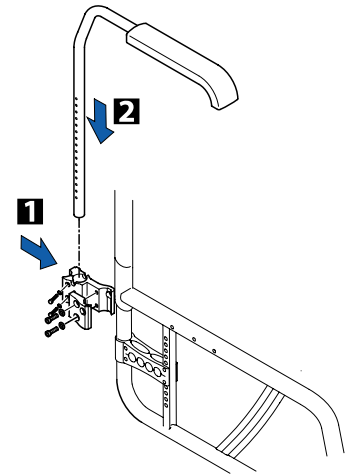
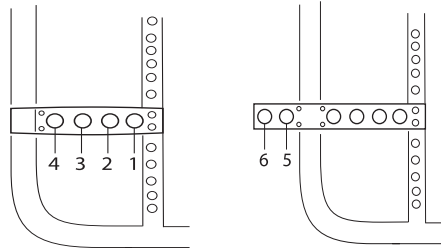
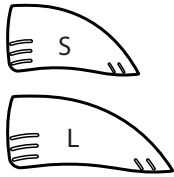

Clothes guard with respect to the position of the rear wheels with standard adapter plate (Pos. 1 to 4) or rear wheel extension (Pos. 5 and 6)

SHh [mm]	Rear wheel 22"						Rear wheel 24"						Rear wheel 25"						Rear wheel 26"					
	1	2	3	4	5	6	1	2	3	4	5	6	1	2	3	4	5	6	1	2	3	4	5	6
380	L	L	L	S	S	S	-	-	-	-	-	-	-	-	-	-	-	-	-	-	-	-	-	-
390	L	L	L	S	S	S	L	L	L	L	L	L	-	-	-	-	-	-	-	-	-	-	-	-
400	L	L	L	S	S	S	L	L	L	L	L	L	-	-	-	-	-	-	-	-	-	-	-	-
410	L	L	S	S	S	S	L	L	L	S	L	L	L	L	L	L	L	-	-	-	-	-	-	
420	L	L	S	S	S	S	L	L	L	S	L	L	L	L	L	L	L	L	L	L	L	L	L	
430	L	S	S	S	S	S	L	L	L	S	L	L	L	L	L	S	S	S	L	L	L	L	S	
440	L	S	S	S	S	S	L	L	L	S	S	S	L	L	L	S	S	S	L	L	L	L	S	
450	S	S	S	S	S	S	L	L	S	S	S	S	L	L	L	S	S	S	L	L	L	S	S	
460	-	-	-	-	-	-	L	L	S	S	S	S	L	L	L	S	S	S	L	L	L	S	S	
470	-	-	-	-	-	-	L	S	S	S	S	S	L	L	S	S	S	S	L	L	L	S	S	
480	-	-	-	-	-	-	L	S	S	S	S	S	L	L	S	S	S	S	L	L	L	S	S	
490	-	-	-	-	-	-	-	-	-	-	-	-	L	S	S	S	S	S	L	L	S	S	S	
500	-	-	-	-	-	-	-	-	-	-	-	-	L	S	S	S	S	S	L	L	S	S	S	



Mudguard mounted fix:

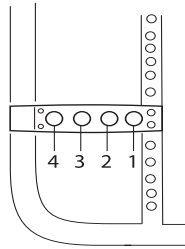
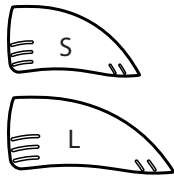

Mudguard (mounted fix) with respect to the position of the rear wheels with standard adapter plate (Pos. 1 to 4)

SHh [mm]	Rear wheel 22"				Rear wheel 24"				Rear wheel 25"				Rear wheel 26"			
	1	2	3	4	1	2	3	4	1	2	3	4	1	2	3	4
410	L	L	S	S	L	L	L	L	L	L	L	L	-	-	-	-
420	L	L	S	S	L	L	L	L	L	L	L	L	L	L	L	L
430	L	S	S	S	L	L	L	L	L	L	L	L	L	L	L	L
440	L	S	S	S	L	L	L	S	L	L	L	L	L	L	L	L
450	S	S	S	S	L	L	S	S	L	L	L	L	L	L	L	L
460	-	-	-	-	L	L	S	S	L	L	L	S	L	L	L	L
470	-	-	-	-	L	S	S	S	L	L	S	S	L	L	L	S
480	-	-	-	-	S	S	S	S	L	S	S	S	L	L	L	S
490	-	-	-	-	-	-	-	-	S	S	S	S	L	L	S	S
500	-	-	-	-	-	-	-	-	S	S	S	S	L	L	S	S

Mudguard removable:

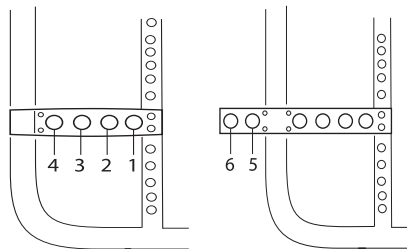
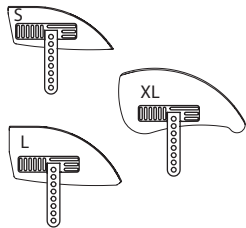

Mudguard (removable) with respect to the position of the rear wheels with standard adapter plate (Pos. 1 to 4) or rear wheel extension (Pos. 5 and 6)

SHh [mm]	Rear wheel 22"						Rear wheel 24"						Rear wheel 25"						Rear wheel 26"					
	1	2	3	4	5	6	1	2	3	4	5	6	1	2	3	4	5	6	1	2	3	4	5	6
380	L	L	L	L	S	S	-	-	-	-	-	-	-	-	-	-	-	-	-	-	-	-	-	-
390	L	L	L	L	S	S	XL	XL	XL	XL	L	L	-	-	-	-	-	-	-	-	-	-	-	-
400	L	L	L	L	S	S	XL	XL	XL	XL	L	L	-	-	-	-	-	-	-	-	-	-	-	-
410	L	L	S	S	S	S	XL	L	L	L	L	L	XL	XL	XL	XL	L	L	-	-	-	-	-	-
420	L	L	S	S	S	S	L	L	L	L	L	L	XL	XL	XL	XL	L	L	XL	XL	XL	XL	L	L
430	L	S	S	S	S	S	L	L	L	L	L	L	XL	L	L	L	S	S	XL	XL	XL	XL	S	S
440	L	S	S	S	S	S	L	L	L	S	S	S	L	L	L	L	S	S	XL	XL	XL	XL	S	S
450	S	S	S	S	S	S	L	L	S	S	S	S	L	L	L	L	S	S	XL	XL	XL	L	S	S
460	-	-	-	-	-	-	L	L	S	S	S	S	L	L	L	S	S	S	XL	XL	XL	L	S	S
470	-	-	-	-	-	-	L	S	S	S	S	S	L	L	S	S	S	S	L	L	L	S	S	S
480	-	-	-	-	-	-	S	S	S	S	S	S	L	S	S	S	S	S	L	L	L	S	S	S
490	-	-	-	-	-	-	-	-	-	-	-	-	S	S	S	S	S	S	L	L	L	S	S	S
500	-	-	-	-	-	-	-	-	-	-	-	-	S	S	S	S	S	S	L	L	S	S	S	S



FRONT WHEELS

Replacing the front wheel

Difficulty: ●○○

Tools: ● 3

- 1 Remove bolts ①, pull out wheel axle ②.
- 2 Remove front wheel ③ and replace with a new one or move to a new position.

(In the case of the Starec wheel, skater wheel, 3" sports wheel and the 5" soft roll wheel, 2 sleeves ④ must be pushed onto the axle. These sleeves are already in place on the low-resistance wheel, the sports wheels and the pneumatic wheels.)

- 3 Re-insert axle ② and tighten bolt ①.

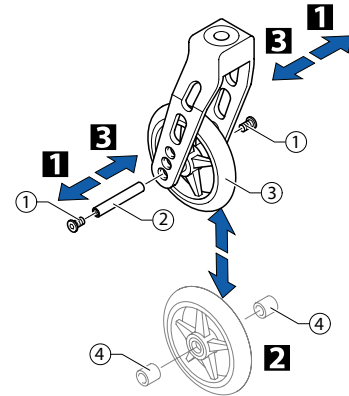

① → 4 Nm

Function check

There must be no pin in the wheel but it must turn easily.

Front wheel fork

Replacing the front wheel fork

Difficulty: ●●○

Tools: ● 3 □ 19

- 1 Remove bolts ①, wheel axle ② and front wheel ③.
- 2 Remove nuts ④ and pull the front wheel fork ⑤ from the clevis pin.
- 3 Replace front wheel fork ⑤ and secure with nut ④ such that the fork has no play.
- 4 Re-insert the front wheel.



CAUTION!

Do not overtighten nut ④, as this can damage the fork bearing.

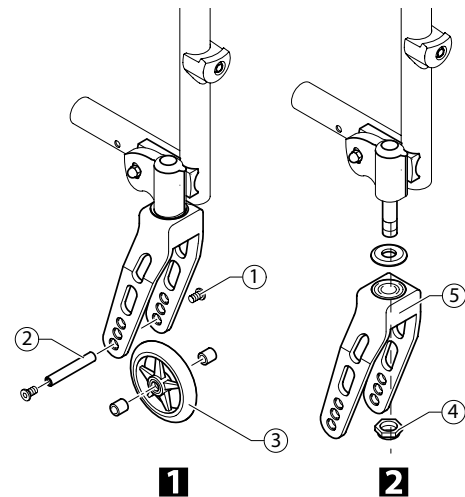

Function check

Tip the wheelchair backwards by 90° so that it is lying on the backrest and the rear wheels. Make sure that the clevis pin is as horizontal as possible. Turn the fork upwards (position A) and let it tip downwards.

The fork has been correctly adjusted if it easily turns to slightly beyond the bottommost point (position B) and then maximally turns back to the bottommost point (position C).

If the fork turns back over the bottommost point or even swings back and forth, it has not been sufficiently tightened. There is a risk that the front wheels will start to wobble at high speeds.

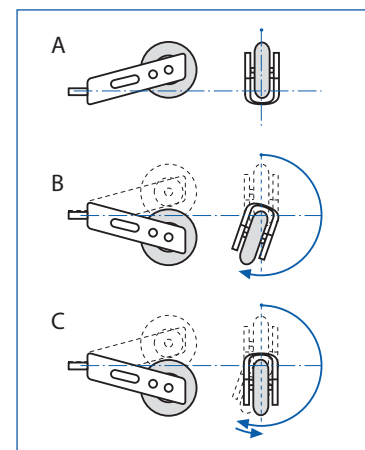



Setting the steering error angle

Difficulty: ●●○

Tools: ●5 ○10

- Loosen bolts ① and nuts ②.
- Hold spirit level against the clevis pin housing ④.
- Turn the bolt ③ until the clevis pin housing is ④ vertical.
- Retighten bolts ① and nuts ②.



CAUTION!

It is important that the settings on the left and right are precisely the same.

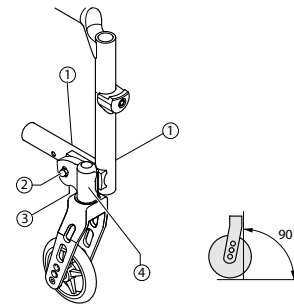

① → 13 Nm

Correcting the trail angle

Difficulty: ●●○

Tools: ●5 ○10

- Loosen bolts ① and nuts ②.
- Remove clevis pin housing ⑤.
- Attach adjustment template ③/④ (for toe-out: insert template at the bottom ③, for toe-in: insert template at the top ④).
- Fit clevis pin housing ②.
- Set the angle, → Chap. Front wheels; Setting the steering error angle, Correcting the trail angle.

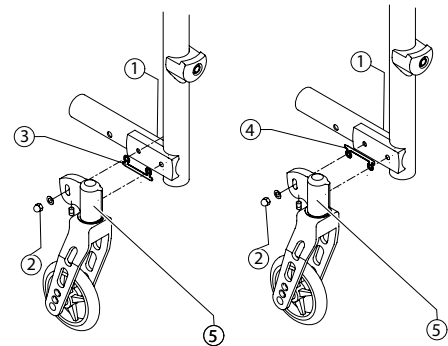

Special housing guides

Fitting special housing guide for smaller SHv (housing guide, fitted high)

Difficulty: ●●○

Tools: ●5 ○10

- Remove clevis pin housing ②.
- Remove standard housing guide.
- Attach bolt ③.
- Fit special housing guide ① high.
- Fit clevis pin housing ②.
- Set the angle, → Chap. Front wheels; Setting the steering error angle, Correcting the trail angle.

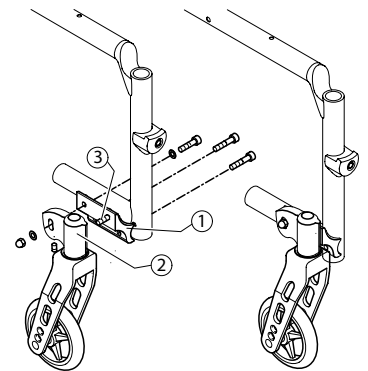

① → 13 Nm

② → 13 Nm

Fitting special housing guide for larger SHv (housing guide, fitted low)

Difficulty: ●●○

Tools: ●5 ○10

- Remove clevis pin housing ②.
- Remove standard housing guide.
- Fit special housing guide ① low.
- Fit clevis pin housing ②.
- Set the angle, → Chap. Front wheels; Setting the steering error angle, Correcting the trail angle.

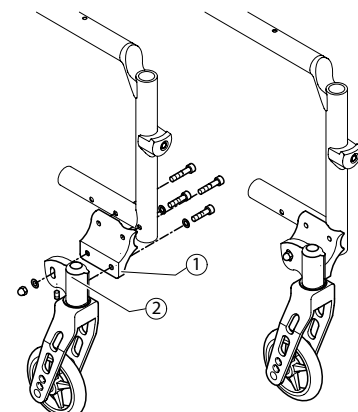



REAR WHEELS

Adjusting the rear seat height

Difficulty: ●○○

Tools: ● 5 ○ 10, 19, 22

- Loosen the bolt of the adapter sleeve ② and bolts ①.
- Remove bolts ③ and move the adapter plate ④ into the required position.
- Insert bolts ③ at the appropriate height.
- Insert the bolt of the adapter sleeve ②.
- Tighten bolts ① and ③.
- Tighten the bolt of the adapter sleeve ②.
- Perform the same setting on both sides.

i After the SHh is changed, the steering error angle must be checked → Chap. Front wheels; Setting the steering error angel, Correcting the trial angel and with a wheel camber of 3° the angle of the rear wheels must also be checked, → Chap. Rear wheels; Changing the wheel camber.

i After the SHh is changed, distance sleeves may also have to be fitted in order to increase the distance to the rear wheels.

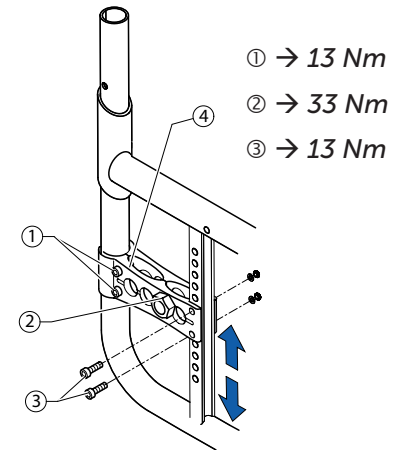

Tipping stability

The tipping stability is influenced by the rear wheel being fitted further forward or further backward on the adapter plate. The further back the adapter sleeve is fitted, the greater the tipping stability of the wheelchair.

If the rear wheel is to be fitted even further back, a rear wheel extension can be fitted to increase the tipping stability even more.

Adjusting the position of the rear wheel on the adapter plate

Difficulty: ●○○

Tools: ○ 19, 22

- 1 Remove the adapter sleeve ①.
 - 2 Set the adapter sleeve ① at the required position in the adapter plate ② and tighten the nut securely.
- Perform the same setting on both sides.

i Parking brakes and mudguard must be repositioned if the position of the rear wheel is changed.

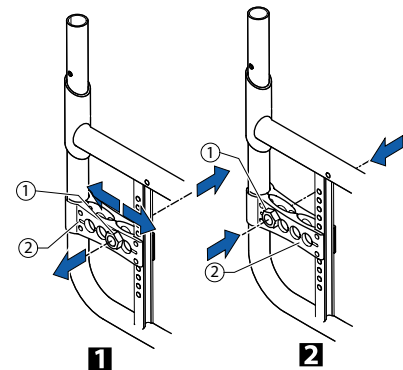

① → 33 Nm

⑤ → 13 Nm

⑥ → 13 Nm

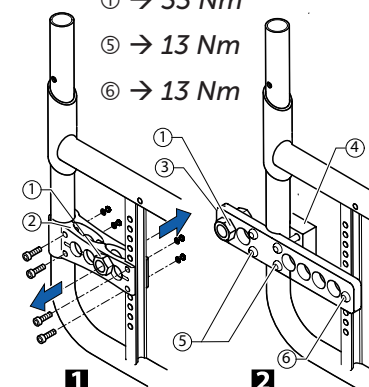

Fitting the rear wheel extension

Difficulty: ●○○

Tools: ● 5 ○ 10, 19, 22

- 1 Remove the adapter sleeve ① and adapter plate ②.
- 2 Position the adapter plate for the rear wheel extension ③ at the required height and tighten securely on the counterpiece ④ using bolts ⑤ and ⑥. Set the adapter sleeve ① at the required position in the adapter plate ③ and tighten the nut securely.



Wheel camber

A wheel camber of either 1° or 3° is possible.

Changing the wheel camber

Difficulty: ●●○

Tools: **C** 18 **H** 19, 22

The wheel camber is changed by replacing the adapter sleeve:

- 1 Remove adapter sleeves ② or ③ on both sides.
- 2 Insert new adapter sleeves ③ and ② on both sides at the required, identical position in the adapter plate ① and fasten securely with nut ④.

Ensuring the rear wheels are parallel

Difficulty: ●●●

Tools: **C** 18 **H** 19, 22

- Loosen nuts ④ of adapter sleeves ③ on both sides.
- At the height of the center of the axle, measure the distance between the rear wheels at the front and back (x, y).

Distance, back > distance, front	Turn adapter sleeve towards rear (viewed from above)
Distance, front > distance, back	Turn adapter sleeve towards front (viewed from above)

- In accordance with the table, turn the adapter sleeves so that the distance between the rear wheels is the same at the front and the back ($x = y$) – measured at the height of the center of the axle.

I At the same time, the distance between the individual wheels and the relevant side frame can be checked for conformity and adjusted if necessary.

- Retighten nuts ④ of adapter sleeves ③ on both sides.

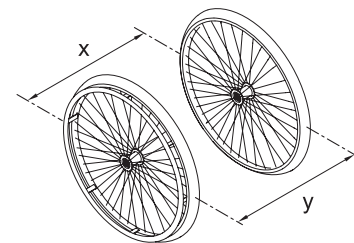
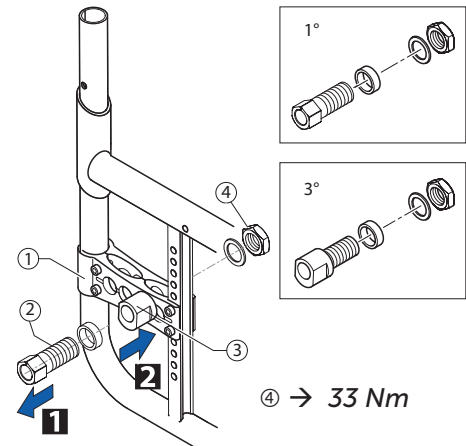

Adjusting the removable axle

Difficulty: ●●○

Tools: **C** 11, 19

- Remove the rear wheel.
- Hold the end of the removable axle ② using the straddle spanner.
- Adjust the length L of the removable axle by turning the nut ①. The length is correctly adjusted if the removable axle engages correctly when fixing the wheel and wheel has just minimal clearance.

I The wheels must be exchanged (left to right side and vice versa) after adjusting both removable axles. The adjustment must now be checked or carried out again to ensure the wheels can be switched.

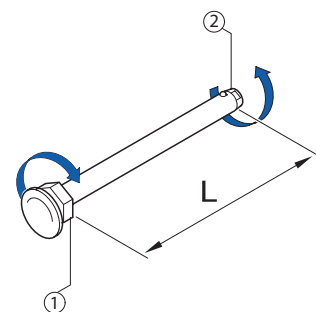



Adapter plate for drum brake

Fitting the adapter plate for the drum brake

Difficulty: ●○○

Tools: ● 5 ◻ 10

- 1 Remove the adapter sleeve ① and adapter plate ②.
- 2 Position the adapter plate for the drum brake ③ at the required height and tighten it securely on the counterpiece ④ using bolts ⑤ and ⑥, → Chap. Brakes; Fitting the drum brake.

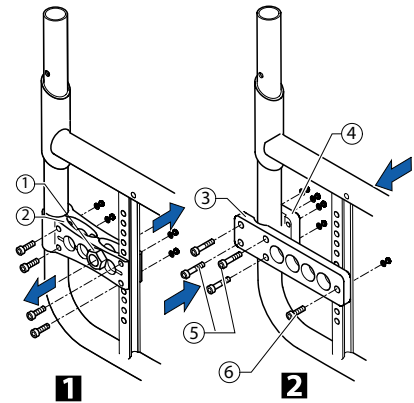

⑤ → 13 Nm

⑥ → 13 Nm

Distance sleeves for rear wheels

If new side parts are fitted on a wheelchair (side rests, arm rests, clothes guard or mudguard), the gap between the rear wheels must be increased by attaching additional distance sleeves. Likewise, distance sleeves may also have to be fitted if other rear wheels are fitted or if the seat height rear is altered.

Repairing or changing an inner tube

Difficulty: ●○○

Tool: tire lever

- Remove the rear wheel and release any air from the inner tube.
- Lift one tire wall away from the rim using a bicycle tire lever. Do not use sharp objects such as a screwdriver which could damage the inner tube.
- Pull the inner tube out of the tire
- Repair the inner tube using a bicycle repair kit or, if necessary, replace the tube.
- Inflate the tube slightly until it becomes round.
- Insert the valve into the valve hole on the rim and place the tube inside the tire (the tube must lie right round the tire with no creases).
- Starting close to the valve, push the tire wall over the edge of the rim using both hands. When doing this, check all the way round to ensure that the inner tube is not trapped between the tire and the rim.
- Inflate the tube to its maximum operating pressure, → Table, chap. Rear wheels, Checking the tire pressure. Check that no air is escaping from the tire.

Repairing or changing a solid tire

Solid tires must be fitted by a qualified technician.



BRAKES

Parking brakes

Mounting the parking brake

Difficulty: ●●○

Tools: ● 5

- Position the brake holder (B) around the front frame tube (C).
- Place the brake (D) in the brake holder.
- Screw the bolt (A) with washer into the brake assembly but do not tighten.
- Rotate the brake holder assembly around the frame tube to adjust the lateral distance of the brake.
- Rotate the brake in the brake holder to achieve a horizontal position of the brake rod (E) to the tire.
- Fully apply the brake and slide it towards the tire until the brake rod bears flush against the tire.
- Release the brake and slide it 3 mm backwards and tighten the bolt.

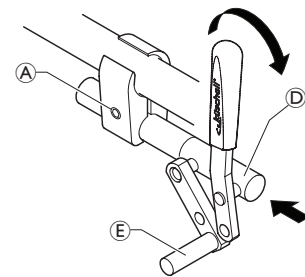
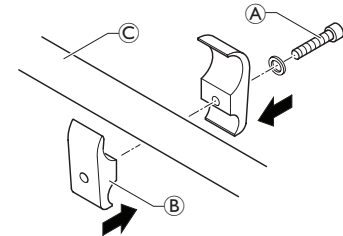

(A) → 13 Nm

Adjusting the parking brake

Difficulty: ●○○

Tools: ● 5



WARNING!

The parking brakes must be readjusted whenever the rear wheels are replaced or the wheel camber is changed.

The parking brake function is only guaranteed if the tire has the corresponding air pressure.

- Check the tire pressure in the rear wheels and correct if necessary.
- Slightly loosen bolt (A) of the brake holder.
- Change the position of the brake assembly as described above.
- Tighten the bolt.



IMPORTANT!

The force to apply the brake must be 60 N (maximum).



Very little force is required for activating and deactivating the brake. If necessary, a brake lever extension can be mounted.

Visual check

Check that the parking brakes are positioned correctly. The brake is set correctly if the brake rod depresses the tire by no more than 4 mm when the brake is applied. (In the case of push/pull and standard brakes this will be the case when the brake shoe is approx. 25 mm away from the tire when released.)

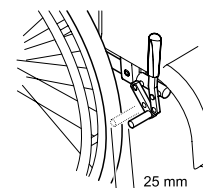

Function check

Place a weighted wheelchair with parking brake engaged facing uphill and then facing downhill on a ramp with an incline of 7°. The wheelchair must not move.



Drum brake

Fitting the drum brake

Difficulty: ●●●

Tools: ● 4, ✕ — C 9 ○ 10, 22

- Remove standard adapter plate and replace with adapter plate for drum brake, → Chap. Rear wheels; Fitting adapter plate for drum brake.
- 1 Fit the drum brake plate ① and rotary fixing ② to adapter plate ③. Connect the drum brake plate and rotary fixing with bolt ④.
- 2 Fit brake lever ⑤ on the push handle and secure Bowden cable ⑥ with fixing set.

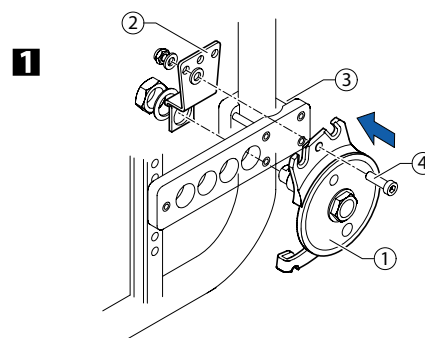

④ → 7 Nm

Setting the drum brake

Difficulty: ●●○

Tool: ○

- Tighten or loosen the brake by turning the setting sleeve ⑦.
- If the setting sleeve cannot be turned any further, demount brake cable ⑥, loosen clamp bolt ⑧ using the screwdriver and retighten the cable.

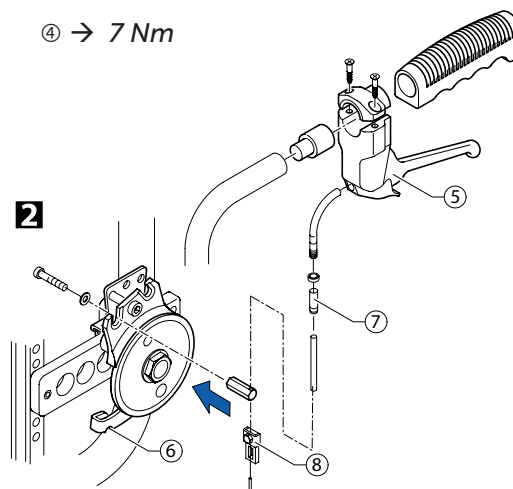



OPTIONS & ACCESSORIES

Antitipper

Fitting an antitipper

Difficulty: ●○○

Tool: ● 5 ◻ 10

- Secure adaptation support ① with bolt ② onto the adapter plate ③.

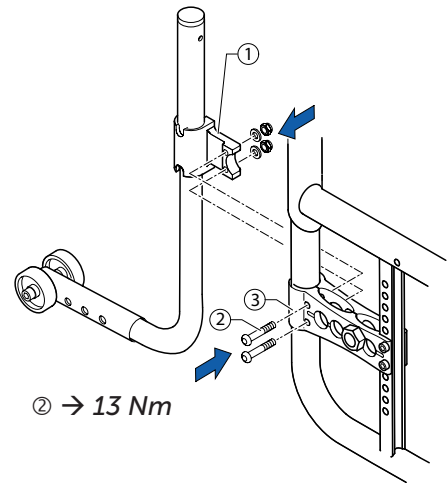

Height adjustment

Difficulty: ●○○

Tool: ● 4 ◻ 8

- Loosen bolt ② and remove the upper end ③ of the antitipper and the holder. Remove the sealing cap ① (e.g. push it out through the tube using the screwdriver).
 - Loosen bolt ⑦ of the antitipper tube and push sleeve ⑥ into the correct position.
 - Screw bolt ⑦ in half way, position spring ⑧ in sleeve ⑥ and screw bolt ⑦ completely into the tube.
 - Put all the parts of the antitipper back together; in doing so pull spring ⑧ apart, e.g. using a wire hook, and secure it with the top bolt ②.
- Set the antitipper parallel to the wheel chair and tighten the bolts.

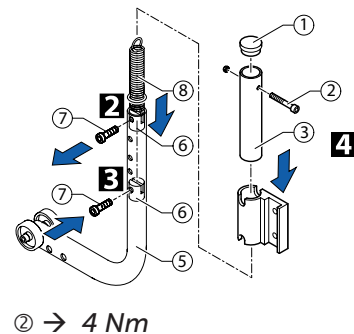
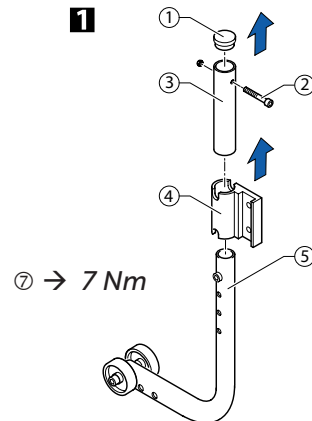

Function check:

The distance between the antitipper and the ground must be 50 - 70 mm. It must be easy to fold up the antitipper.

Tip the wheelchair backwards using the antitipper until the axle is perpendicular to the antitipper's point of contact with the ground. In this position, the distance between the rear wheel and the ground must be at least 50 mm.

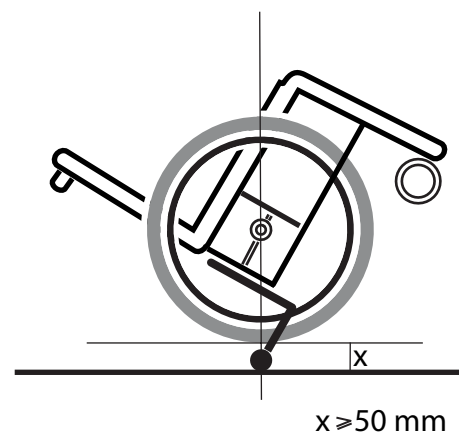



Tipper aid

Fitting the tipper aid

Difficulty: ●○○

Tool: ● 5 ◻ 10

- Secure adaptation support ① with bolt ② onto adapter plate ③. Push in spring clip ④ and push the tipper aid into the adaptation support.
- Make sure that the spring clip is correctly engaged in the adaptation support.

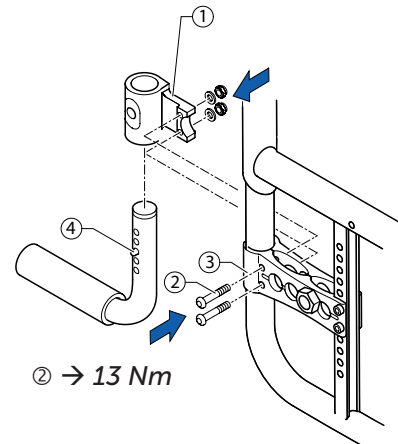

Height adjustment

Difficulty: ●○○

- To adjust the height, remove cap ⑤ and, e.g. using a screwdriver, compress the spring ④ inside the tube and push into the required position.

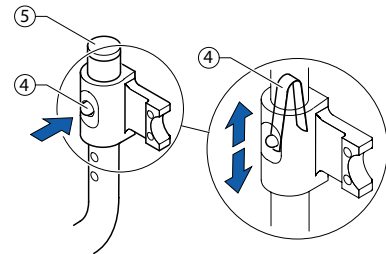

Cane holder

Fitting a cane holder

Difficulty: ●○○

Tool: ● 5 ◻ 10

- Secure adaptation support ① with bolt ② onto adapter plate ③. Push in spring clip ④ and push the cane holder into the adaptation support.
- Make sure that the spring clip is correctly engaged in the adaptation support.

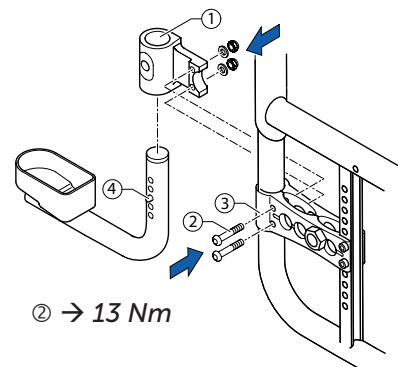

Height adjustment

Difficulty: ●○○

- To adjust the height, remove cap ⑤ and, e.g. using a screwdriver, compress spring ④ inside the tube and push into the required position.

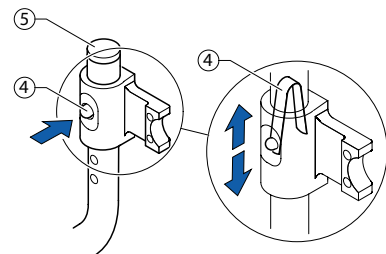



Transit wheels

Fitting transit wheels

Difficulty: ●○○

Tool: ● 5, ◻ 10

- Secure adaptation support ① with bolts ② onto adapter plate ③. Push in spring clip ④ and push the transit wheel into the adaptation support.
- Make sure that the spring clip is correctly engaged in the adaptation support.

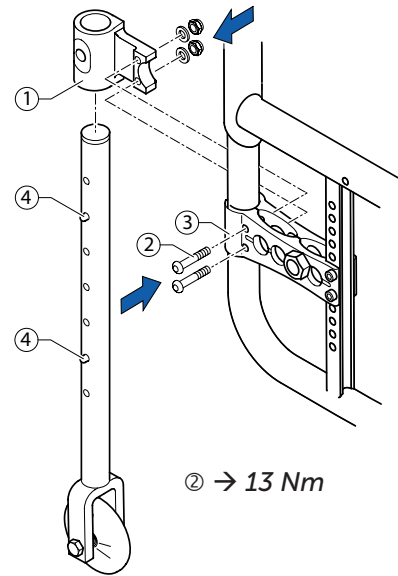

Height adjustment

Difficulty: ●○○

- To adjust the height, remove cap ⑤ and, e.g. using a screwdriver, compress spring ④ inside the tube and push into the required position..

 To bring the transit wheels into the upper or lower position, the spring clip must be pressed in.

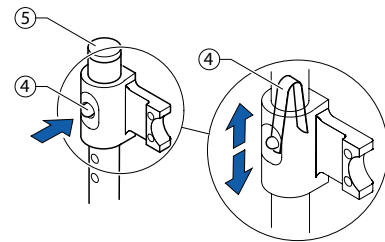

Mounting the posture belt

Difficulty: ●○○

Tools: Drill, drill bit: Ø 6 mm ● 5 ◻ 10

1. If not present, drill a hole ④ on both sides through the frame ②.
2. Attach the steel strap ① using bolts ③ through the holes ④ on both sides.

 Ensure that the webbing of the posture belt is not twisted during assembly and the locking mechanism shows towards the front.

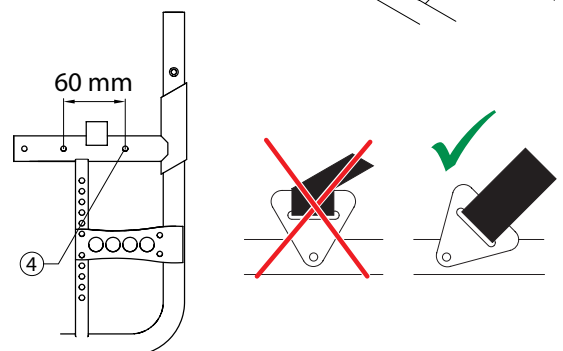
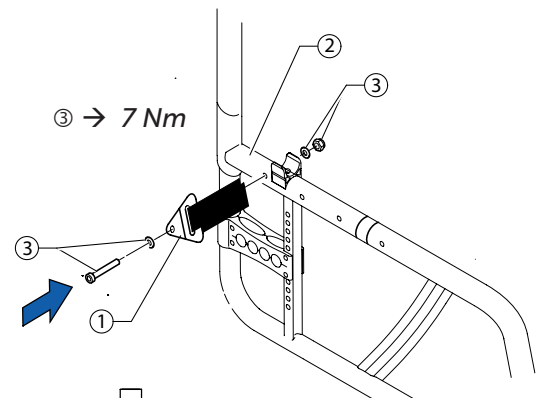



Attaching the snap hook symbols

Front side

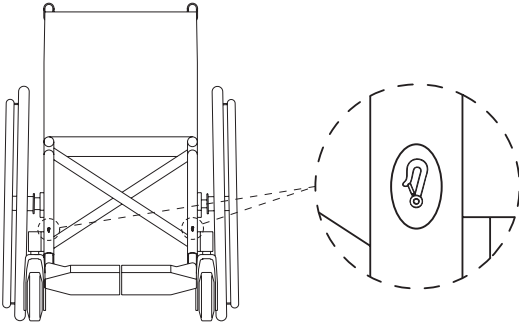

Rear side

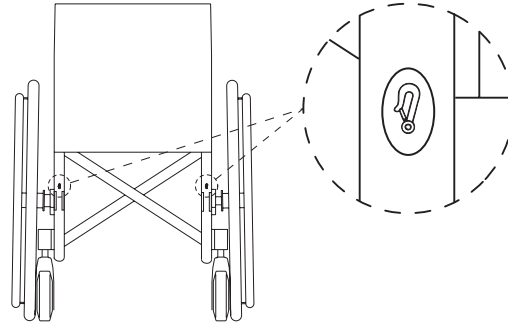



Invacare France Operations
Route de St Roch
F-37230 Fondettes
France

Service Manual
KÜSCHALL COMPACT
ENGLISH | 2018-07

Invacare distributors:

Belgium & Luxemburg: Invacare nv • Autobaan 22 • B-8210 Loppem

Tel: (32) (0)50 83 10 10 • Fax: (32) (0)50 83 10 11 • belgium@invacare.com • www.invacare.be

Danmark: Invacare A/S • Sdr. Ringvej 37 • DK-2605 Brøndby

Tel: (45) (0)36 90 00 00 • Fax: (45) (0)36 90 00 01 • denmark@invacare.com • www.invacare.dk

Deutschland: Invacare GmbH • Alemannenstraße 10 • D-88316 Isny

Tel: (49) (0)75 62 7 00 0 • Fax: (49) (0)75 62 7 00 66 • kontakt@invacare.com • www.invacare.de

Eastern Europe, Middle East & CIS: Invacare EU Export • Kleiststraße 49 • D-32457 Porta Westfalica

Tel: (49) (0)57 31 754 540 • Fax: (49) (0)57 31 754 541 • webinfo-eu-export@invacare.com • www.invacare-eu-export.com

España: Invacare SA • c/Areny s/n • Polígon Industrial de Celrà • E-17460 Celrà (Girona)

Tel: (34) (0)972 49 32 00 • Fax: (34) (0)972 49 32 20 • contactsp@invacare.com • www.invacare.es

France: Invacare Poirier SAS • Route de St Roch • F-37230 Fondettes

Tel: (33) (0)2 47 62 64 66 • Fax: (33) (0)2 47 42 12 24 • contactfr@invacare.com • www.invacare.fr

Ireland: Invacare Ireland Ltd • Unit 5 Seatown Business Campus • Seatown Road • Swords • County Dublin – Ireland

Tel : (353) 1 810 7084 • Fax: (353) 1 810 7085 • ireland@invacare.com • www.invacare.ie

Italia: Invacare Mecc San s.r.l. • Via dei Pini 62 • I-36016 Thiene (VI)

Tel: (39) 0445 38 00 59 • Fax: (39) 0445 38 00 34 • italia@invacare.com • www.invacare.it

Nederland: Invacare BV • Galvanistraat 14-3 • NL-6716 AE Ede

Tel: (31) (0)318 695 757 • Fax: (31) (0)318 695 758 • nederland@invacare.com • www.invacare.nl

Norge: Invacare AS • Grensesvingen 9 • Postboks 6230 • Etterstad • N-0603 Oslo

Tel: (47) (0)22 57 95 00 • Fax: (47) (0)22 57 95 01 • norway@invacare.com • island@invacare.com • www.invacare.no

Österreich: Invacare Austria GmbH • Herzog Odilostrasse 101 • A-5310 Mondsee

Tel.: (43) 6232 5535 0 • Fax.: (43) 6232 5535 4 • info@invacare-austria.com • www.invacare.at

Portugal: Invacare Lda • Rua Estrada Velha • 949 • P-4465-784 Leça do Balio

Tel: (351) (0)225 1059 46/47 • Fax: (351) (0)225 1057 39 • portugal@invacare.com • www.invacare.pt

Sverige: Invacare AB • Fagerstagatan 9 • S-163 91 Spånga

Tel: (46) (0)8 761 70 90 • Fax: (46) (0)8 761 81 08 • sweden@invacare.com • finland@invacare.com • www.invacare.se

Suomi: Camp Mobility • Patamäenkatu 5 • 33900 Tampere

Tel: 09-35076310 • info@campmobility.fi • www.campmobility.fi

Schweiz/Suisse/Svizzera: Invacare AG • Benkenstrasse 260 • CH-4108 Witterswil

Tel.: (41) (0)61 487 70 80 • Fax.: (41) (0)61 487 70 81 • switzerland@invacare.com • www.invacare.ch

United Kingdom: Invacare Limited • Pencoed Technology Park,

Pencoed, Bridgend CF35 5AQ • Switchboard Tel: (44) (0)1656 776 200, Fax: (44) (0)1656 776 201 •

Customer services Tel: (44) (0) 1656 776 222 • Fax: (44) (0) 1656 776 220 • UK@invacare.com • www.invacare.co.uk

Australia: Invacare Australia Pty Ltd • ABN 45 074 676 378, PO Box 5002, 1 Lenton Place, North Rocks, NSW 2151, Australia •

Freephone: 1800 069 042, Fax: 02 8839 5353 • E-mail: sales@invacare.com.au • Web: www.invacare.com.au

New Zealand: Invacare New Zealand • PO Box 62-124, 4 Westfield Place, Mt. Wellington, Auckland, New Zealand •

Freephone: 8000 468 222, Freefax: 0800 807 788 • E-mail: sales@invacare.co.nz • Web: www.invacare.co.nz