

Invacare® Fox

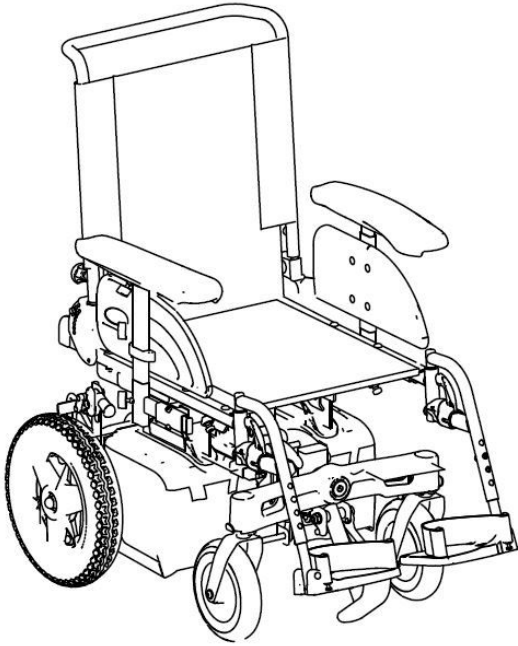

en Power Wheelchair Service Manual



PROVIDER: Keep this manual.
The procedures in this manual MUST be performed by a qualified technician.



Yes, you can.®

© 2020 Invacare Corporation

All rights reserved. Reproduction, duplication or modification in whole or in part is prohibited without prior written permission from Invacare. Trademarks are identified by ™ and ®. All trademarks are owned by or licensed to Invacare Corporation or its subsidiaries unless otherwise noted.

Making Life's Experiences Possible is a registered trademark in the U.S.A.

Contents

1 General	4
1.1 Introduction	4
1.2 General Information	4
1.3 Notes on Shipping	4
1.4 Symbols in this Manual	4
1.5 Images in This Manual	5
2 Safety	6
2.1 Safety information	6
2.2 Safety and Fitting Instructions	6
3 Hygiene	8
3.1 Handling of Returned Used Products	8
4 Components	9
4.1 Overview Mobility Device	9
5 Setup	11
5.1 General information on setup	11
5.2 Adjusting Seating Position	11
5.2.1 Adjusting Lower Leg Length	11
5.3 Adjusting Seat Depth	11
5.4 Adjusting Seat Depth via Backrest Unit	11
5.5 Adjusting Seat Height	12
5.5.1 Adjusting Seat Height via Centre Column	12
5.5.2 Adjusting Seat Height via Seat Support	13
5.6 Adjusting Seat Tilt	13
5.7 Adjusting Centre of Gravity of Seat	13
5.8 Adjusting Safety Latch	15
6 Testing	16
6.1 Testing Motor	16
6.2 Testing Motor Brake	16
6.3 Rain test	16
6.4 Field Load Test	17
6.5 Checking Battery Charge Level	17
7 Service	19
7.1 General Warning Information on Installation Work	19
7.2 Tightening Torques	19
7.3 Service Plan	19
7.4 Troubleshooting	21
7.4.1 Operational Faults	21
7.4.2 Drive fault diagnosis	21
7.5 Chassis	22
7.5.1 Changing Wheelbase	22
7.5.2 Replacing / Reversing Swinging Axle	22
7.5.3 Replacing Kerb Climber (L-Shape Lever)	23
7.5.4 Replacing Rubber Foot	24
7.5.5 Replacing Rubber Stopper	25
7.6 Drive Components	25
7.6.1 Replacing Motor/Gearbox Unit	25
7.7 Shrouds	26
7.7.1 Rear Shroud	26
7.7.2 Battery Shroud	27
7.8 Electrical components	28
7.8.1 Replacing Power Module	28
7.8.2 Batteries	28
7.8.3 Replacing Batteries	29
7.8.4 Installing / Removing Battery Boxes	30
7.8.5 Handling Damaged Batteries Correctly	30
7.8.6 Replacing remote	31
7.8.7 Drive Program Selection After Component Replacement	31
7.8.8 Updating driving program	31
7.8.9 Checking Cables	31
7.8.10 Resetting Circuit Breaker	31
7.9 Wheels	31
7.9.1 Tyre Pressure	31
7.9.2 Tyre Types	32
7.9.3 Specific Tightening Torques	32
7.9.4 Overview of Power Wheelchair Models and Wheel Types	33
7.9.5 Replacing Drive Wheel (1-Bolt Installation)	35
7.9.6 Replacing Manual Wheel Lock	36
7.9.7 Replacing Castor Wheel on Double-Sided Fork	37
7.9.8 Replacing Tyres	39
7.9.9 Replacing Front Fork	40
7.9.10 Replacing Caster Locks	41
7.9.11 Replacing Anti-Tipper Wheels	42
7.9.12 Replacing Steering Head Bearings on Steering Wheels	43
7.9.13 Installing Ball Bearings	44
7.10 Seating	44
7.10.1 Moving Seat Into Service Position / Removing Seat	44
7.10.2 Replacing Seat Frame (Fox Seat)	44
7.10.3 Replacing Fabric Seat (Padded)	46
7.10.4 Replacing Fabric Seat (Stretched)	46
7.10.5 Replacing Seat Plate	47
7.10.6 Replacing Safety Latch	48
7.11 Headrest/Neckrest	48
7.11.1 Replacing Rea Headrest	48
7.11.2 Replacing Rea Headrest Mounting Bracket (Sling Backrest)	48
7.12 Backrest	49
7.12.1 Replacing Standard Backrest	49
7.12.2 Replacing Backrest Holder With Quick Release System	49
7.13 Armrests	50
7.13.1 Replacing Armrest	50
7.13.2 Installing Inrigged Armrest (Wooden Seat Plate)	51
7.13.3 Replacing Armrest Holder	51
7.14 Replacing Foot Plate / Heel Strap of Legrest	52
7.15 Posture Belt	52
7.15.1 Replacing Posture Belt	52
7.16 Lighting Unit	53
7.16.1 Replacing Headlight	53
7.16.2 Replacing Rear Light	53

1 General

1.1 Introduction

This document contains important information about assembly, adjustment and advanced maintenance of the product. To ensure safety when handling the product, read this document and the user manual carefully and follow the safety instructions.

Find the user manual on Invacare's website or contact your Invacare representative. See addresses at the end of this document.

Invacare reserves the right to alter product specifications without further notice.

Before reading this document, make sure you have the latest version. You find the latest version as a PDF on the Invacare website.

For pre-sale and user information, see the user manual.

For more information about the product, for example product safety notices and product recalls, contact your Invacare representative. See addresses at the end of this document.

1.2 General Information

Service and maintenance work must be carried out taking this document into account.

It is imperative that you observe safety information.

Information about operation or about general maintenance and care work on the product should be taken from service manual.

Assembly of accessories might not be described in this document. Refer to the manual delivered with the accessory. Additional manuals can be ordered from Invacare. See addresses at the end of this document.

You can find information about ordering spare parts in the spare parts catalogue.

Spare parts must match original Invacare parts. Only use spare parts which have been approved by Invacare.

The product may only be maintained and overhauled by qualified personnel.

The minimum requirement for service technicians is suitable training, such as in the cycle or orthopedic mechanics fields, or sufficiently long-term job experience. Experience in the use of electrical measuring equipment (multimeters) is also a requirement. Special Invacare training is recommended.

Alterations to the mobility device which occur as a result of incorrectly or improperly executed maintenance or overhaul work lead to the exclusion of all liability on the side of Invacare.

If you have any problems or questions contact your provider.

1.3 Notes on Shipping

- If the mobility device has to be shipped back to the manufacturer for major repairs, you should always use the original packaging for transport.
- Please attach a precise description of the fault.

1.4 Symbols in this Manual

Symbols and signal words are used in this manual and apply to hazards or unsafe practices which could result in personal injury or property damage. See the information below for definitions of the signal words.



DANGER

Indicates a hazardous situation that will result in serious injury or death if it is not avoided.



WARNING

Indicates a hazardous situation that could result in serious injury or death if it is not avoided.



CAUTION

Indicates a hazardous situation that could result in minor or slight injury if it is not avoided.



IMPORTANT

Indicates a hazardous situation that could result in damage to property if it is not avoided.



Gives useful tips, recommendations and information for efficient, trouble-free use.



Identifies required tools, components and items which are needed to carry out certain work.

1.5 Images in This Manual

The detailed images in this manual are given marks to identify various components. Component marks in text and operational instructions always relate to the image directly above.

2 Safety

2.1 Safety information



WARNING!

The procedures in this service manual, must be performed by a specialized dealer or qualified service technician.

- Do not handle this product or any available optional equipment without first completely reading and understanding these instructions and any additional instructional material such as user manuals, installation manuals or instruction sheets supplied with this product or optional equipment.



The information contained in this document is subject to change without notice.

2.2 Safety and Fitting Instructions

These safety instructions are intended to prevent accidents at work, and it is imperative that they are observed.

Before any inspection or repair work

- Read and observe this repair manual and the associated user manual.
- Observe the minimum requirements for carrying out the work (see 1.2 *General Information, page 4*).

Personal Safety Equipment

Safety shoes

The mobility device, and some of its components, are very heavy. These parts can result in injuries to the feet if they are allowed to drop.

- Wear standardized safety shoes during all work.

Eye protection

It is possible that battery acid can be discharged when working on defective batteries or when handling batteries improperly.

- Always wear eye protection when working on any defective or possibly defective batteries.

Safety gloves

It is possible that battery acid can be discharged when working on defective batteries or when handling batteries improperly.

- Always wear acid-proof safety gloves when working on any defective or possibly defective batteries.

General Safety Information and Information About Fitting / Removal



DANGER!

Risk of Death, Serious Injury, or Damage

Lighted cigarettes dropped onto an upholstered seating system can cause a fire resulting in death, serious injury, or damage. Mobility device occupants are at particular risk of death or serious injury from these fires and resulting fumes because they may not have the ability to move away from the mobility device.

- DO NOT smoke while using this mobility device.



WARNING!

Risk of Serious Injury or Damage

Storing or using the mobility device near open flame or combustible products can result in serious injury or damage.

- Avoid storing or using the mobility device near open flame or combustible products.



CAUTION!

Risk of crushing

Various components such as the drive unit, batteries, seat etc are very heavy. This results in injury hazards to your hands.

- Note the high weight of some components. This applies especially to the removal of drive units, batteries and the seat.



CAUTION!

Injury hazard if the mobility device starts moving unintentionally during repair work

- Switch the power supply off (ON/OFF key).
- Engage the drive.
- Before lifting up, secure the mobility device by using chocks to block the wheels.

**CAUTION!****Fire and burn hazard due to electrical short-circuit**

- The mobility device must be completely switched off before removal of voltage-carrying components! To do this, remove the batteries.
- Avoid short-circuiting the contacts when carrying out measurements on voltage-carrying components.

**CAUTION!****Risk of burns from hot surfaces on the motor**

- Allow the motors to cool down before commencing work on them.

**CAUTION!****Injury hazard and risk of damage to mobility device due to improper or incomplete maintenance work**

- Use only undamaged tools in good condition.
- Some moving parts are mounted in sockets with PTFE coating (Teflon™). Never grease these sockets!
- Never use "normal" nuts instead of self-locking nuts.
- Always use correctly-dimensioned washers and spacers.
- When reassembling, always replace any cable ties which were cut during dismantling.
- After completing your work / before renewed start-up of the mobility device, check all connections for tight fitting.
- After completing your work / before renewed start-up of the mobility device, check all parts for correct locking.
- Only operate the mobility device with the approved tyre pressures (see technical data).
- Check all electrical components for correct function. Note that incorrect polarity can result in damage to the control system.
- Always carry out a trial run at the end of your work.

**CAUTION!****Risk of injury and damage to property, if the maximum speed reduction on a wheelchair with a lifter does not function correctly**

The wheelchair's control unit must reduce the maximum possible speed as soon as the lifter is raised.

- Test the maximum speed reduction for correct function after any maintenance work or modifications to the wheelchair.

**CAUTION!****Any changes to the drive program can affect the driving characteristics and the tipping stability of the mobility device**

- Changes to the drive program may only be carried out by trained Invacare providers.
- Invacare supplies all mobility devices with a standard drive program ex-works. Invacare can only give a warranty for safe mobility device driving behavior - especially tipping stability - for this standard drive program.



Mark all current settings for the mobility device (seat, armrests, backrest etc.), and the associated cable connecting plugs, before dismantling. This makes reassembly easier. All plugs are fitted with mechanical locks which prevent release of the connecting plugs during operation. To release the connecting plugs the safety locks must be pressed in. When reassembling ensure that these safety locks are correctly engaged.

3 Hygiene

3.1 Handling of Returned Used Products

When reconditioning or repairing returned mobility devices:

- Take precautions for yourself and the product.
- Use protection equipment as specified locally.

Before Transport (According to Biological Agents Ordinance)

Treat product according to following process steps:

Process Step	Component	Application	Conditioning technique	Work Station
Manual cleaning	Surface of used device	Before repair or reconditioning	Use saturated towel to apply cleaning detergent and remove residues after impact.	Cleaning and disinfection
Disinfection	Surface of used device	Before repair or reconditioning	Use saturated disinfectant wipes and clean* the device surface.	Cleaning and disinfection

*Invacare uses detergent "Nücosept special" 1.5% in water ml/ml

Disinfection Tools

- Disposable wipes (fleece)
- Brushes to clean areas difficult to access

Further Information

 For more information contact your Invacare service department.

4 Components

4.1 Overview Mobility Device

Under Rear Shroud

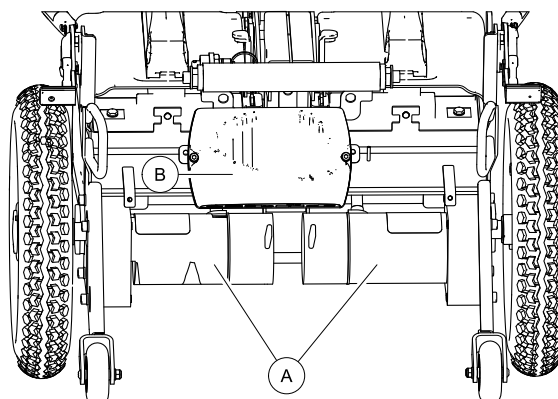

Fig. 4-1

Ⓐ: Drive units

Ⓑ: Power module

Under Seat

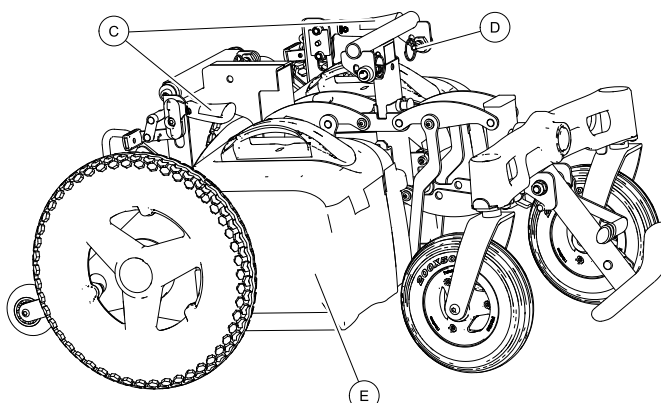

Fig. 4-2

Ⓒ: Manual wheel lock

Ⓓ: Safety latches for seat

Ⓔ: Battery boxes

Special Features

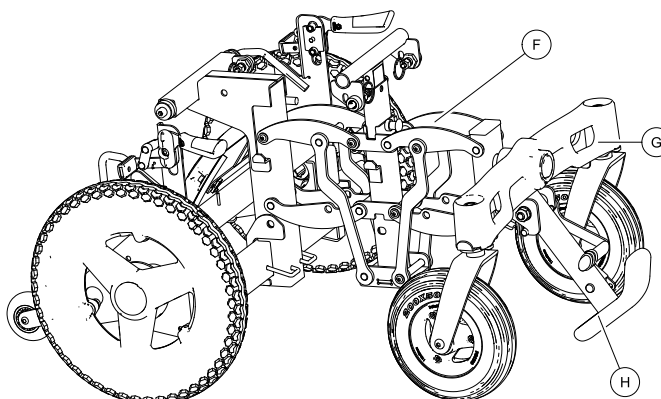

Fig. 4-3

Ⓕ: Scissor system

Ⓖ: Swinging axle

Ⓖ: Kerb climber

Modulite Seat Options

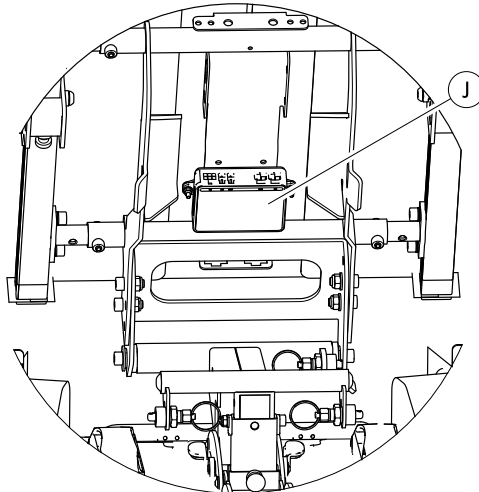

Fig. 4-4

Ⓧ: Actuator module (ACT200) under seat plate.

5 Setup

5.1 General information on setup

The tasks described in this chapter are intended to be performed by trained and authorized service technicians for initial setup. They are not intended to be performed by the user.

5.2 Adjusting Seating Position

For adjusting seating position to adapt mobility device optimally to requirements of user, we recommend that you ask your provider to adjust the seat depth individually. Adapting seat to user's seating position depends on which seat has been installed, and should be carried out in following sequence.



WARNING!

Risk of injury after tilting of mobility caused by blocked steering wheels.

- Always check seat depth settings for both forward and reverse movement. Make sure that steering wheels can rotate freely and have not contact to any fixed mobility device component.



CAUTION!

Any changes to drive program can affect driving characteristics and tipping stability of mobility device.

- Changes to drive program may only be carried out by providers.
- We supplies all mobility devices with a standard drive program ex-works. We can only give a warranty for safe mobility device driving behavior - especially tipping stability - for this standard drive program.

1. Adjust lower leg length and seat depth. See 5.2.1 *Adjusting Lower Leg Length*, page 11 and 5.3 *Adjusting Seat Depth*, page 11.
2. Adjust seat height and seat tilt. See 5.5 *Adjusting Seat Height*, page 12 and user manual for seat tilt.
3. Adjust centre of gravity of seat frame. See 5.7 *Adjusting Centre of Gravity of Seat*, page 13.
4. Check that swivel casters can move freely.
5. Repeat steps two to four, if necessary.

5.2.1 Adjusting Lower Leg Length

Invacare offers a range of legrests which can be adjusted individually. See user manual.

5.3 Adjusting Seat Depth

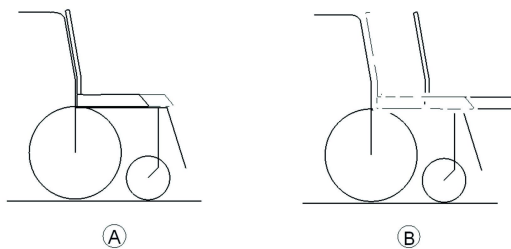

Ⓐ: Seat depth

Ⓑ: Center of gravity of the seat/ seat position

5.4 Adjusting Seat Depth via Backrest Unit



When removing, take care of small parts such as screws and washers. Put all small parts down so that they can be installed in correct sequence.

Adjusting Seat Depth (up to August 2014)



- Phillips screwdriver, size 2
- 8 mm wrench
- Side cutting pliers
- Cable ties

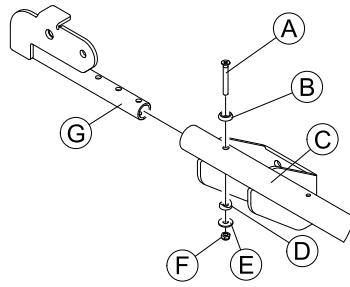

1. Disconnect cable connections.
2. Loosen and remove nut (F) plain washer (E), saddle washer (D), rosette (B) and bolt (A).
3. Position backrest mounting bracket (G) according to seat depth, so that holes on seat frame (C) and backrest mounting bracket (G) are in line.
4. Install seat. See 7.10.4 *Replacing Fabric Seat (Stretched)*, page 46 or 7.10.3 *Replacing Fabric Seat (Padded)*, page 46.
5. Re-insert nut (F), plain washer (E), saddle washer (D), rosette (B) and bolt (A). Tighten nut (F).
6. Insert backrest tube into backrest mounting bracket. See 7.12 *Backrest*, page 49.
7. Connect cable connections.
8. Test all functions.

Adjusting Seat Depth (Since August 2014)



- Phillips screwdriver, size 2
- 8 mm Allen key
- Side cutting pliers
- Cable ties

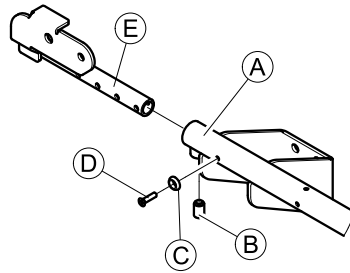

1. Disconnect cable connections.
2. Loosen and remove screw (D) and rosette (C).
3. Loosen set screw (B).
4. Position backrest mounting bracket (E) according to seat depth, so that the holes on seat frame (A) and backrest mounting bracket are in line.
5. Tighten set screw (B) hand-tight.
6. Install seat. See 7.10.4 *Replacing Fabric Seat (Stretched)*, page 46 or 7.10.3 *Replacing Fabric Seat (Padded)*, page 46.
7. If not done in previous step, tighten screw (D) including rosette (C).
8. Insert backrest tube into backrest mounting bracket. See 7.12 *Backrest*, page 49.
9. Connect cable connections.
10. Test all functions.

5.5 Adjusting Seat Height

5.5.1 Adjusting Seat Height via Centre Column



- 5 mm Allen key
- 10 mm wrench

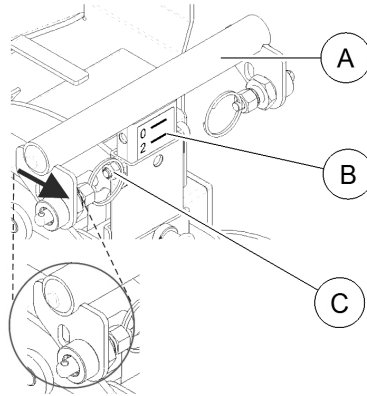

Fig. 5-1

Seat height can be set to two different seat heights using scale (B). Adjust seat height according to following table:

480 mm	Use left scale (default value: 4)
510 mm	Use right scale (default value: 4)

1. Remove seat. See 7.10.1 *Moving Seat Into Service Position / Removing Seat, page 44.*
2. Loosen and remove bolt and nut (C).
3. Adjust centre column (A).
4. Install parts in reverse order.
5. Test all functions.

5.5.2 Adjusting Seat Height via Seat Support



- 6 mm Allen key
- 8 mm wrench



When removing, take care of small parts such as screws and washers. Put all small parts down so that they can be installed in correct sequence.

Seat can be set to two different seat heights. Adjust seat height according to following table:

480 mm	upper holes
510 mm	lower holes

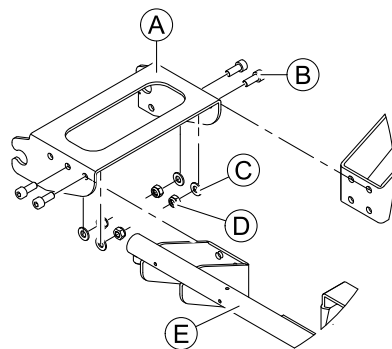

1. Remove seat from chassis. See 7.10.1 *Moving Seat Into Service Position / Removing Seat, page 44.*
2. Loosen and remove four bolts (B) on both sides, including washers (C) and nuts (D).
3. Align holes on seat frame and seat support and insert bolts.
4. Re-insert washer and nut and re-tighten bolt.
5. Install seat. See 7.10.1 *Moving Seat Into Service Position / Removing Seat, page 44.*
6. Test all functions.

5.6 Adjusting Seat Tilt

See user manual.

5.7 Adjusting Centre of Gravity of Seat

Centre of gravity of seat can be adjusted by mounting seat frame farther towards front or rear on seat.



WARNING!

The seating system of the mobility device is delivered ex works with an optimally adjusted centre of gravity (CoG). Any change in this adjustment setting can negatively influence the stability of the mobility device.
 – You must perform an individual risk analysis every time you change the centre of gravity of the seating position, in order to ensure the safety and stability of the mobility device.

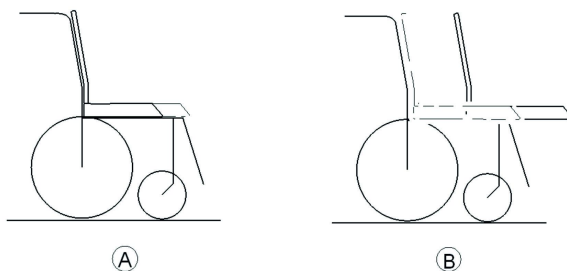

A: Seat depth

B: Centre of gravity of the seat / seat position



The user weight and seat depth have strong influences on the choice of the centre of gravity (CoG). If the user is heavy and the seat depth is greater, the focus should be the farther back. For best possible driving characteristics of rear-wheel drive wheelchairs, the weight to be distributed: 30 – 40 % front and 60 - 70 % rear.

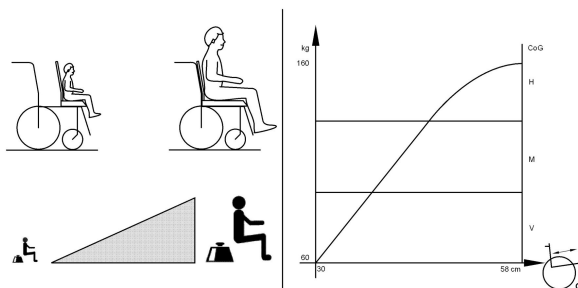

WARNING!

Risk of damage due to collisions of legrests with other parts of the mobility device

- Set legrests to the smallest angle before adjusting the seat centre of gravity.
- Pay attention with adjusting the seat centre of gravity that the legrests do not touch any other parts of the mobility device. This ensures that the legrests can not collide with other parts of the mobility device.



- 6 mm Allen key
- 8 mm wrench



When removing, take care of small parts such as screws and washers. Put all small parts down so that they can be installed in correct sequence.

Seat can be set to two different positions. Adjust seat support according to following table:

Rear position	rear and middle hole
Front position	middle and front hole

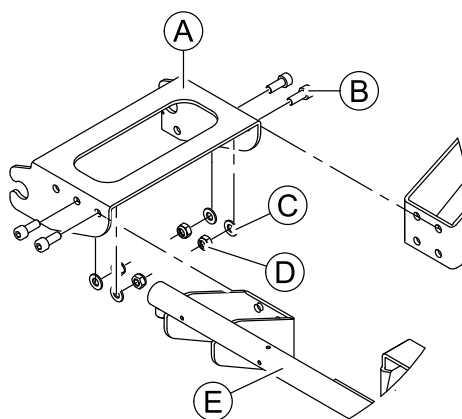

Fig. 5-2

1. Remove seat. See 7.10.1 *Moving Seat Into Service Position / Removing Seat*, page 44.
2. Loosen and remove four bolts **B**, washers **C** and nuts **D** on both sides.
3. Shift position of seat.
4. Align holes on seat frame and seat support and insert bolts.
5. Re-insert washer and nut and re-tighten bolt.
6. Install seat. See 7.10.1 *Moving Seat Into Service Position / Removing Seat*, page 44.
7. Test all functions.

5.8 Adjusting Safety Latch



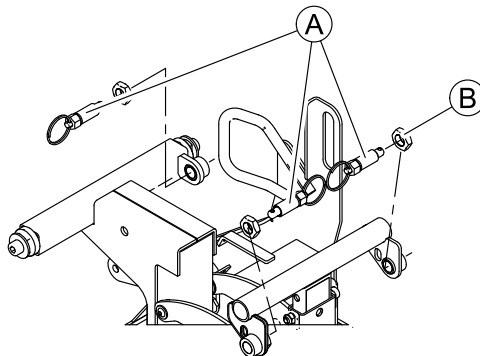

- 19 mm wrench
- 12 mm wrench



1. Loosen adjusting nut **B**.
2. Screw out/in safety latch **A** so that the spring-loaded catch engages securely and is flush with the outside edge when it is pulled.
3. Tighten adjusting nut with $15 \text{ Nm} \pm 1 \text{ Nm}$.

6 Testing

6.1 Testing Motor

-  • Phillips screwdriver, size 2
-  • Digital multimeter with resistance measurement

1. Remove shroud that covers power module. See 7.7 *Shrouds*, page 26.
2. Unplug cable of motor (A) from power module.
3. Connect multimeter (B) to motor plug contacts (C) and (D) and measure resistance between contacts.

 A resistance of between 0.5 ohms and 5 ohms indicates a motor ready for operation. A resistance of between 15 ohms and infinity indicates a defective motor. High resistances are normally caused by bad connections or worn carbon brushes.

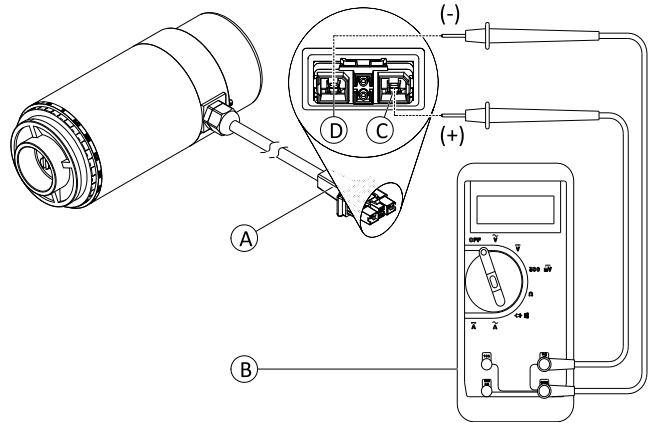



Fig. 6-1 DuraWatt motor serves as an example.

6.2 Testing Motor Brake

 This test should only be carried out on mobility device with conventional motor-gearbox units.





CAUTION!

Risk of damage to power module due to shorts in motor brake

- NEVER connect a shorted motor brake to an intact power module.
- Always replace shorted brakes immediately.

 A defective motor can damage the power module, but a defective power module cannot damage the motor.

-  • Phillips screwdriver, size 2
-  • Digital multimeter with resistance measurement

1. Remove shroud that covers power module. See 7.7 *Shrouds*, page 26.
2. Unplug cable of motor (A) from power module.
3. Connect multimeter (B) to motor plug contacts (E) and (F) and measure resistance between contacts.

 A resistance of between 40 ohms and 80 ohms indicates an intact brake. A resistance of 0 ohms or a very high resistance (mega-ohms or infinity) indicates a short-circuit, a bad connection or a defective brake.

4. If there is a defect, replace motor and send it to Invacare Service for inspection or repair.

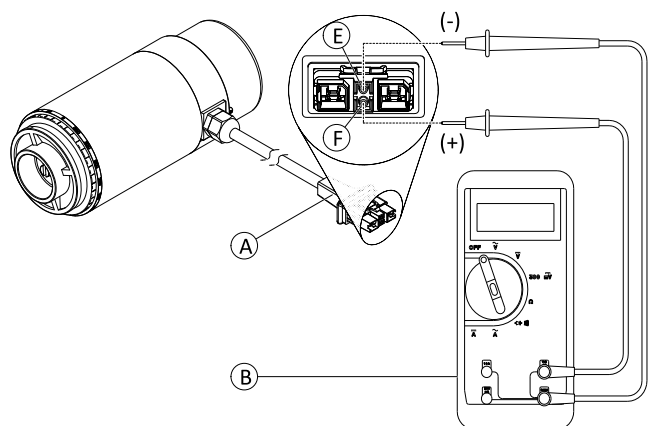



Fig. 6-2 DuraWatt motor serves as an example.

6.3 Rain test

- Check to ensure that the black battery terminal caps are secured in place, gaiter is not torn or cracked where water can enter and that all electrical connections are secure at all times.
- Do not use the mobility device if the gaiter is torn or cracked. If the gaiter becomes torn or cracked, replace immediately.

6.4 Field Load Test

Old batteries lose their ability to store and release power due to increased internal resistance. In this procedure, batteries are tested under load using a digital voltmeter to check battery charge level at the charger connector. The charger connector is located on the remote. When voltage at the output drops 1.0 volts under load (2.0 volts for a pair), replace the batteries.

 Read these instructions carefully and the manufacturer's instructions on the digital voltmeter before proceeding.

 • Voltmeter



WARNING!

– When performing the following steps, ensure your feet are clear from casters and wall, otherwise injury may result.

1. Switch electronics OFF on remote.
2. Make sure battery is fully charged. An extremely discharged battery will exhibit the same symptoms as a bad battery.
3. Remove footboard/legrests from mobility device.
4. Connect voltmeter leads to charger connector **(A)** on mobility device. Most digital voltmeters **(B)** are not affected by polarity. However, analog meters (meters with swinging needles) can be and should be used carefully.

 A good meter reading should be 25.5 VDC to 26.0 VDC with the chair in neutral.

5. Switch electronics ON on remote.
6. Ensure that your feet are clear from casters and wall.
7. Run mobility device in neutral for at least 2 minutes.
8. Sit in mobility device and place your feet against a door jam, workbench or other stationary object.
9. Carefully give forward command, trying to drive the mobility device through the stationary object. The load should draw between 30 amps to 40 amps from the batteries for 0.3 seconds.

 Performing this step puts a heavy load on the batteries as they try to push through the stationary object. If the wheels spin, have two individuals (one on each arm) apply as much downward pressure as possible on the arms of the mobility device.

10. Read meter while motors are straining to determine voltage under load.

 If the voltage drops more than 2.0 volts from a pair of fully charged batteries during the 0.3 seconds, they should be replaced regardless of the unloaded voltages.

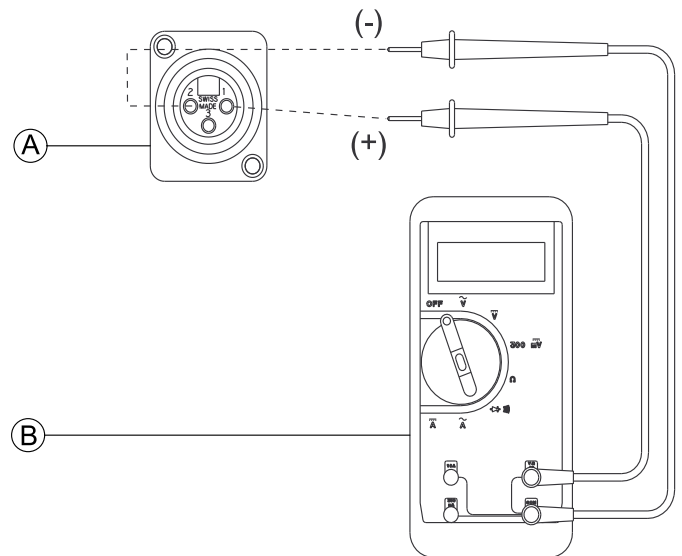

Fig. 6-3

6.5 Checking Battery Charge Level

The following “Dos” and “Don’ts” are provided for your convenience and safety.

DON'T	DO
Don't perform any installation or maintenance without first reading this manual.	Read and understand this manual and any service information that accompanies a battery and charger before operating the personal transporter.
Don't perform installation or maintenance of batteries in an area that could be damaged by battery spills.	Move the personal transporter to a work area before cleaning terminals, or opening battery box.
Don't make it a habit to discharge batteries to the lowest level.	Recharge as frequently as possible to maintain a high charge level and extend battery life.

DON'T	DO
Don't use chargers or batteries that are not appropriate for the chair.	Follow recommendations in this manual when selecting a battery or charger.
Don't put new batteries into service before charging.	Fully charge a new battery before using.
Don't tip or tilt batteries.	Use a carrying strap to remove, move or install a battery.
Don't tap on clamps and terminals with tools.	Push battery clamps on the terminals. Spread clamps wider if necessary.
Don't mismatch your battery and chargers.	Use only a AGM charger for a AGM battery.

7 Service

7.1 General Warning Information on Installation Work

CAUTION!
Risk of damage to vehicle

Collisions can be caused if the adjusting washers are removed during fitting work to the drive wheels. Adjusting washers are often fitted between the drive shaft and the wheel hub to even out tolerances. If these adjusting washers are removed and not replaced again, collisions can be caused.

- Always replace the adjusting washers exactly as they were before you started dismantling.

CAUTION!
Risk of injury and damage to property, if the maximum speed reduction on a mobility device with a lifter does not function correctly

The mobility device's control unit must reduce the maximum possible speed as soon as the lifter is raised.

- Test the maximum speed reduction for correct function after any maintenance work or modifications to the mobility device.

7.2 Tightening Torques

CAUTION!
Risk of damage to mobility device due to improperly tightened screws, nuts or plastic connections.

- Always tighten screws, nuts etc. to the stated tightening torque.
- Only tighten screws or nuts which are not listed here fingertight.

The tightening torques stated in the following list are based on the thread diameter for the nuts and bolts for which no specific values have been determined. All values assume dry and de-greased threads.

Thread	Tightening Torque in Nm $\pm 10\%$
M4	3 Nm
M5	6 Nm
M6	10 Nm
M8	25 Nm
M10	49 Nm
M12	80 Nm
M14	120 Nm
M16	180 Nm

7.3 Service Plan

Component	Check	Remedy	Notes	✓
Armrests	Damage to armrests	Replace covering if damaged		
	Armrest fixings	Tighten screws		
Side panels	Damage to side panels	Replace side panels if damaged		
	Side panel fixings	Tighten screws		
Seat lock	Seat lock defective	Replace seat lock		
Seat angle adjustment	Tight seating of retainer clip	Replace retainer clip if necessary		
Frames (chassis) / battery mounting	Check fixings, welded seams and battery mounting	Tighten screws		
		Replace components if necessary		

Component	Check	Remedy	Notes	✓
Wheel suspension and wheels	Check drive wheels for tight fit and side play	Adjust, replace wheel hubs	See 7.9 <i>Wheels, page 31</i>	
	Check steering wheels for tight fit, float and side play	Replace wheels, wheel fork or wheel bearings		
Swinging axle	Check castor locks	Replace castor locks	See 7.9.12 <i>Replacing Steering Head Bearings on Steering Wheels, page 43</i>	
	Checking swinging axle for damage	Replacing swinging axle	See 7.5.2 <i>Replacing / Reversing Swinging Axle, page 22</i>	
Drive units, coupling mechanism	Check functions in drive and push modes	Replace motor if necessary		
	Check coupling mechanism	Tighten screws / nuts, adjust or replace if necessary		
Legrests	Check welded seams, interlocking, screws, foot-plates	Tighten, replace if necessary		
Powered legrests (if installed)	Check cable	Replace cable if necessary		
	Check contacts			
	Check functions			
Lighting (if installed)	Check cable	Replace lamp or cable if necessary		
	Check function			
Batteries	Check batteries for damage	Replace batteries, if necessary	See user manual	
	Check battery voltage	Charge batteries	See user manual	
	Check contacts and terminals	Clean contacts and terminals	Refer to safety information in 7.8.5 <i>Handling Damaged Batteries Correctly, page 30</i> for handling batteries	
Battery case	Check locking system, it must engage completely	Replace if necessary		
Remote / electronics module	Remote, status display blinking	Evaluate error / blink code		
	Fixings	Tighten fixings, replace if necessary		
	Cables and connecting plugs	Tighten cables and connecting plugs, replace if necessary		
	Drive lever function	Replace drive lever if necessary		
		Replace remote if necessary		
Power supply	Tighten cables and connecting plugs. Replace, if necessary			

Component	Check	Remedy	Notes	✓
Drive program	Check drive electronics program version	Update software if newer version available.	See 7.8.8 <i>Updating driving program, page 31</i>	
Screws	Check screws for tight fit	Tighten screws, if necessary		

7.4 Troubleshooting

7.4.1 Operational Faults

Proceed as follows if you have any problems:

1. First assess the possible cause of the problem using the following table.
2. Check the remote status display. Evaluate the flash error code.
3. Carry out the necessary checks and repairs as recommended in the following table.

The various power modules can be fitted in connection with different remotes in the mobility device. Rectification of operational faults depends on the power module fitted. The power modules used are described in the corresponding controls manual.





The tables for rectification of operational faults listed in the following chapters are only an excerpt from the original manufacturer's manuals. You can obtain the original manuals from Invacare.

7.4.2 Drive fault diagnosis

Problem	Other symptoms	Possible cause	Solution	Documentation
Mobility device will not start	The remote status display illuminates normally and does not show an error code.	Drive motors disengaged	Engage drive motors	See user manual
	Remote status display does not illuminate	Batteries defective	Replace batteries	See 7.8.2 <i>Batteries, page 28</i>
		Completely discharge battery	Pre-charge batteries	See user manual
		Power supply to remote interrupted	Reset circuit breaker	See 7.8.10 <i>Resetting Circuit Breaker, page 31</i>
			Check cables between the modules for loose connections and damage	See 7.8.9 <i>Checking Cables, page 31</i>
	Remote defective	Replace remote	See 7.8.6 <i>Replacing remote, page 31</i>	
Remote status display blinking	Various causes	Assess error code	See corresponding remote manual.	
Mobility device judders in drive mode	None	Batteries defective (unstable voltage)	Replace batteries	See 7.8.2 <i>Batteries, page 28</i>
		Drive motor(s) defective	Replace motor(s)	See 7.6.1 <i>Replacing Motor/Gearbox Unit, page 25</i>
Batteries not being charged	None	Batteries defective	Replace batteries	See 7.8.2 <i>Batteries, page 28</i>
	LEDs blinking on charging unit	Charging unit defective	Replace charging unit	See 'Charging unit' in user manual
Mobility device runs too slowly	None	Remote defective	Replace remote	See corresponding remote manual
		Batteries defective	Replace batteries	See user manual

7.5 Chassis

7.5.1 Changing Wheelbase

-  • 5 mm Allen key
-  • 10 mm wrench

1. Remove seat. See 7.10.1 *Moving Seat Into Service Position / Removing Seat*, page 44.
2. Loosen and remove bolt and nut ③.
3. Adjust centre column.

- Long wheelbase
Adjustment of centre column ① on chassis
→ Scale ② is at front.

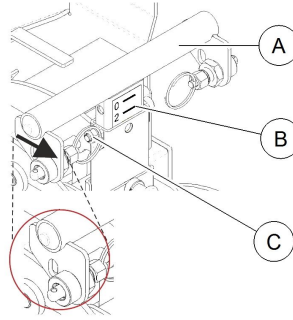

- Short wheelbase
Adjustment of centre column ① on chassis
→ Scale ② is at rear.

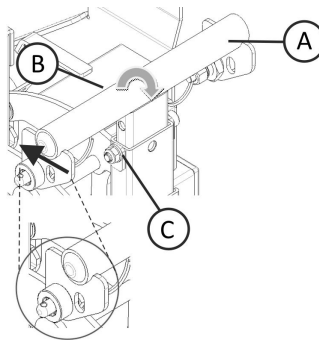

 Changing wheelbase influences seat depth and centre of gravity (CoG), see 5.7 *Adjusting Centre of Gravity of Seat*, page 13. You may need to adjust seat depth via centre column to meet your requirements. See user manual.

4. Install parts in reverse order.
5. Test all functions.

7.5.2 Replacing / Reversing Swinging Axle

 The swinging axle can be rotated to change the wheelbase length.

Choose swinging axle orientation:

Figure ①	long wheelbase
Figure ②	short wheelbase

If you change wheelbase, centre column on chassis must be adapted accordingly. See 7.5.1 *Changing Wheelbase*, page 22.

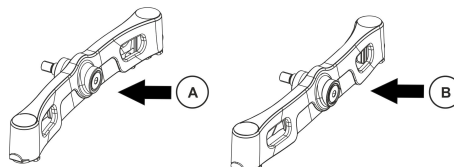

**WARNING!****Risk of injury due to uncontrolled movement of mobility device**

- Turn off power.
- Engage motors.
- Secure mobility device against rolling away by placing wedges under wheels.

**CAUTION!****Risk of injury from swinging axle coming loose**

- If swinging axle is insufficiently secured, it can come loose when driving.
- When mounting swinging axle tighten screw with appropriate torque.
 - Make sure swinging axle has no play.

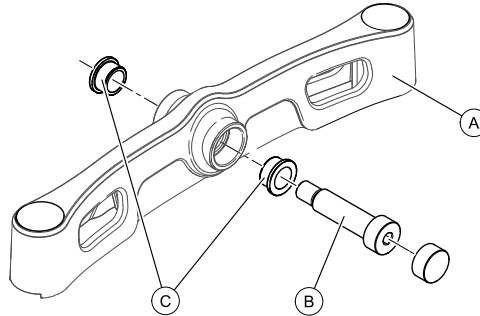

- 10 mm Allen key
- Wooden block (approx. 14 x 14 x 30 cm)
- Medium strength thread locking adhesive

**Removing Swinging Axle**

1. Remove legrests.
2. Place wooden block under kerb climber so that swinging axle hangs free.
3. Heat screw ② to soften thread locking adhesive.
4. Remove screw ②.
5. Pull swinging axle ① off chassis and remove bushings ③.

Installing Swinging Axle

1. Install parts in reverse order.
2. Apply medium strength thread locking adhesive.
3. Tighten screw ② to 70 Nm \pm 10 Nm.

7.5.3 Replacing Kerb Climber (L-Shape Lever)**CAUTION!****Risk of crushing**

- Injury hazard to hands. The gas spring is under pressure.
- Be careful with your hands.
 - Use suitable tools.



- 3 mm Allen key
- 6 mm Allen key
- 8 mm wrench
- 17 mm wrench
- Pliers
- Oblong wooden block (approx. 14 x 14 x 30 cm)



When removing, take care of small parts such as screws and washers. Put all small parts down so that they can be installed in correct sequence.

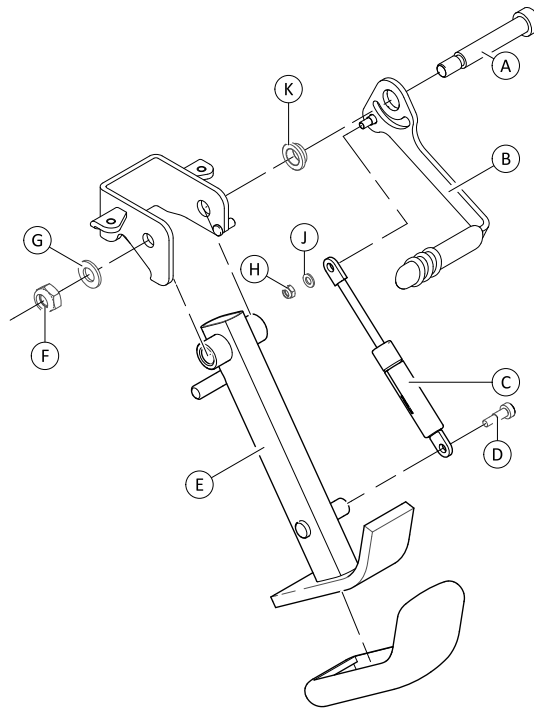

Removing Kerb Climber

1. Secure mobility device against rolling away.
2. If necessary, remove parts that are in the way like legrests or swinging axle.
3. Loosen and remove screw ⑩.
4. Pull gas spring ③ out of holder.
5. Loosen and remove nut ⑥ including washer ⑦.
6. Pull bolt ① out of holder.
7. Remove switch lever ② including bushing ⑫, gas spring ③, washer ⑪ and nut ④.
8. If needed, loosen and remove nut ④ including washer ⑪ and replace gas spring ③.

Installing Kerb Climber

 When applying the correct tightening torque to nut ⑥, ensure that kerb climber can move freely.

1. Install parts in reverse order.
2. Test all functions.

7.5.4 Replacing Rubber Foot

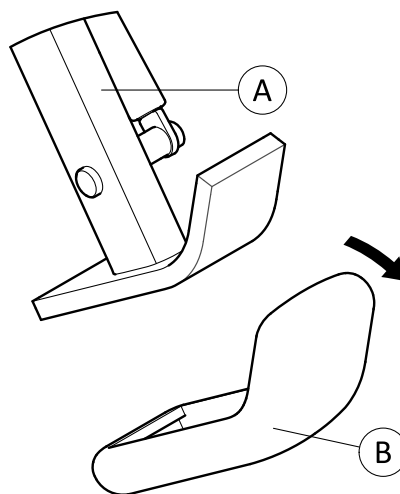

1. Pull front part of old rubber foot ② off kerb climber ① in forward direction.
2. Place rear part of new rubber foot over kerb climber.
3. Push front part of new rubber foot over kerb climber.

7.5.5 Replacing Rubber Stopper

 We recommend to replace all rubber stoppers as soon as one needs replacing.



- 10 mm wrench

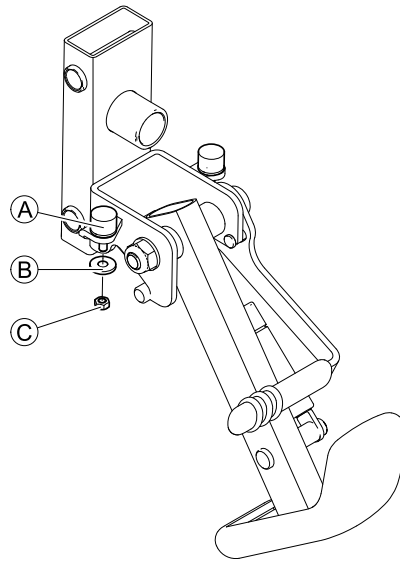

Fig. 7-1

Removing Rubber Stopper

1. Remove swinging axle. See 7.5.2 *Replacing / Reversing Swinging Axle*, page 22.
2. Loosen and remove nut © and washer ʙ.
3. Remove rubber stopper ʌ.

Installing Rubber Stopper

1. Tighten new rubber stopper ʌ hand-tight.
2. Place washer ʙ and nut ©, then counter nut ʘ.
3. Install swinging axle. See 7.5.2 *Replacing / Reversing Swinging Axle*, page 22.

7.6 Drive Components

7.6.1 Replacing Motor/Gearbox Unit



CAUTION!

Risk of injury due to uncontrolled movement of mobility device.

- Turn off power.
- Engage motors.
- Secure mobility device against rolling away by placing wedges under wheels.



CAUTION!

Risk of crushing

Motor gearbox unit is extremely heavy. Risk of injury to hands.

- Note the high weight.



- 5 mm Allen key
- Oblong wooden blocks (approx. 14 x 14 x 30 cm)



Before replacing motor/gearbox unit, make sure motor plug matches power module type.

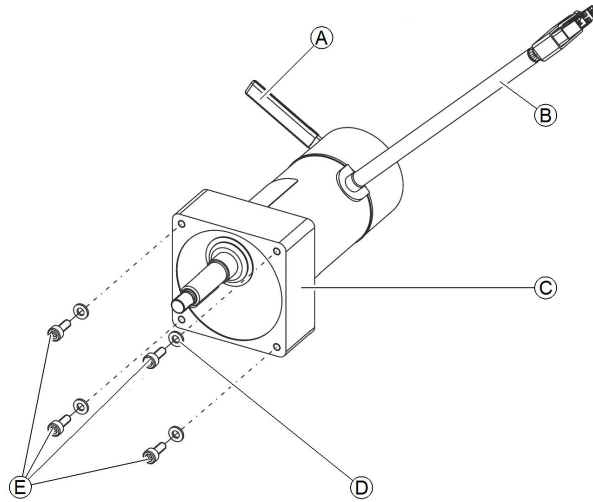

Removing Motor / Gearbox Unit

1. Remove rear shroud. See *7.7 Shrouds, page 26*.
2. Lift mobility device on one side and place a 14 cm high wooden block underneath it so that drive wheel is off ground and can rotate freely. Use proper lifting techniques.
3. Pull motor plug **B** out of power module. Plugs differ according to controls systems.
4. Remove drive wheel. See *7.9.5 Replacing Drive Wheel (1-Bolt Installation), page 35*.
5. Loosen and remove screws **E** including washers **D**.
6. Pull motor gearbox unit **C** downwards out of chassis. Take into account heavy weight of unit.
7. Replace drive unit.

Installing Motor / Gearbox Unit

Before installing new motor / gearbox unit, check whether it should be installed to left-hand or right-hand side of mobility device. The drive units are different.

 Note labelling on motor plug.

1. Install parts in reverse order.
2. Connect motor cable **B** to power module.
3. Make sure that motor cable cannot be pinched or bent, and that it is not exposed to chafing in any place.
4. Tighten screws **E** to $7 \text{ Nm} \pm 1 \text{ Nm}$.
5. If LiNX system is used, perform calibration process. See *Suggested programming procedure* in LiNX service manual.
6. Test all functions.

7.7 Shrouds

7.7.1 Rear Shroud



- 3 mm Allen key
- Oblique pliers
- Tie wrap

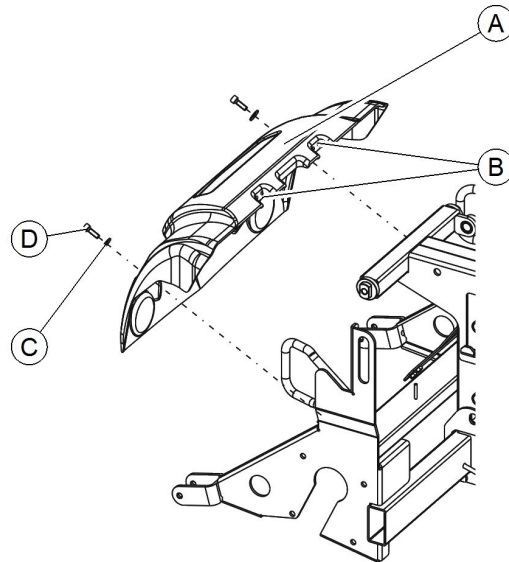

Removing Rear Shroud

1. Remove cable tie from bus cable in notch **B** right or left.
2. Loosen and remove two screws **D** including washer **C** on rear shroud **A**.
3. Pull rear shroud carefully away from chassis.

Installing Rear Shroud

1. Push rear shroud over chassis.
2. Make sure bus cable is located in notch **B**.
3. Tighten screws **D** including washer **C**. Tighten screws to $3 \text{ Nm} \pm 1 \text{ Nm}$.
4. Fix bus cable using tie wrap.

7.7.2 Battery Shroud



- 5 mm Allen key

Removing Battery Shroud

1.

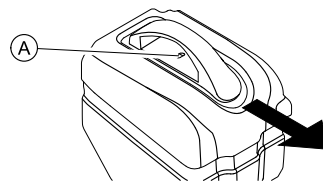

Press safety lock on top of battery box **A** and remove handle.

2.

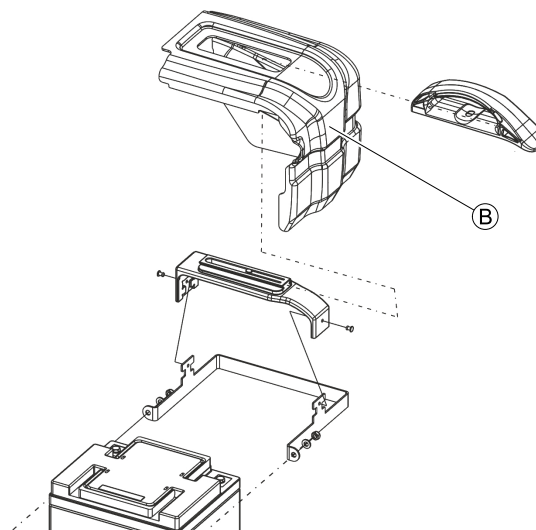

Remove battery shroud **B** from battery box.

Installing Battery Shroud

1. Install battery shroud.
2. Install handle to shroud. Make sure safety lock engages.

7.8 Electrical components

7.8.1 Replacing Power Module

The various power modules can be installed to the mobility device with a range of different remotes. Power modules are described in corresponding controls manuals or earlier revisions of this manual. Replacement is described below using LiNX power module as an example. The course of action is the same for other power modules. The only difference is the terminal layout.



CAUTION!

Any changes to the drive program can affect the driving characteristics and the tipping stability of the mobility device

- Changes to the drive program may only be carried out by trained providers.
- Invacare can only give a warranty for safe mobility device driving behaviour - especially the tipping stability - for unaltered standard drive programs.



All power modules are delivered with a standard drive program. If you have carried out customer-specific modifications to the drive program, you will have to make these changes again after installing new power module.

Removing Power Module

- Phillips screwdriver, size 2
- To adapt the drive program: Programming software or hand programming device and system installation manual, available from Invacare.

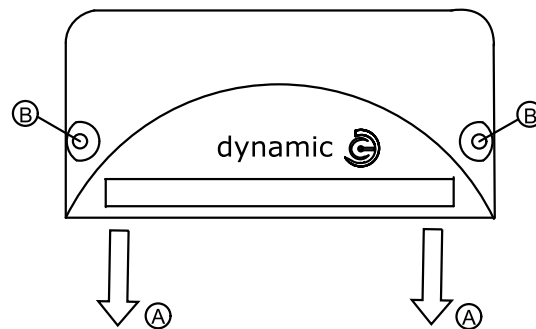

Fig. 7-2

1. Remove rear shroud. See 7.7.1 Rear Shroud, page 26.
2. Remove all plugs Ⓐ from power module.



Mark positions of individual plugs for later re-installing.

3. Loosen and remove screws Ⓑ on both sides of power module.
4. Remove power module.

Installing Power Module

- For details on cable routing and information about Updating drive program and Adapting drive program, see LiNX Service Manual.

1. Install parts in reverse order.
2. If LiNX system is used, perform calibration process. See *Suggested programming procedure* in LiNX service manual.
3. If available, update drive program.
4. If necessary, adapt drive program to user's need.
5. Test all functions.

7.8.2 Batteries



CAUTION!

Injury hazard and possible material damages if batteries are handled improperly

- The installation of new batteries may only be carried out by authorised specialists.
- Observe the warning information on the batteries.
- Only use battery versions stated in the specifications.

**CAUTION!****Fire and burns hazard if battery terminal is bypassed**

- Take great care to ensure that the battery terminals are never short-circuited with tools or mechanical mobility device parts.
- Ensure that the battery terminal caps have been replaced if you are not working on the battery terminals.

**CAUTION!****Risk of crushing**

- Batteries can be extremely heavy. This results in injury hazards to your hands.
- Handle the batteries with care.
 - Ensure that batteries do not fall to the ground when removed from chassis.
 - Pay attention to hands.
 - Use proper lifting techniques.

**WARNING!****Burn hazard**

Injury hazard due to discharged acid.

- Always wear acid-proof protective gloves when handling batteries.
- Always wear protective goggles when handling batteries.

What to do if acid is discharged

- Always take clothing which has been soiled by or dipped in acid off immediately!
- Rinse any areas of your skin which has come into contact with battery acid off immediately with plenty of water!

If contact with eyes is made

- You should also consult an eye specialist immediately afterwards!



When removing, take care of small parts such as screws and washers. Put all small parts down so that they can be installed in correct sequence.

7.8.3 Replacing Batteries

Before replacing batteries ensure the following:

- Never mix and match different battery manufactures or technologies, or use batteries that do not have similar date codes.
- Never mix gel with AGM batteries.



Different battery types are used on this product type. Illustrations can differ from installed batteries on your mobility device.



- 5 mm Allen key
- 10 mm wrench
- cable tie
- depending on battery type additionally:
 - 8 mm wrench,
 - 10 mm wrench, or
 - 11 mm wrench.

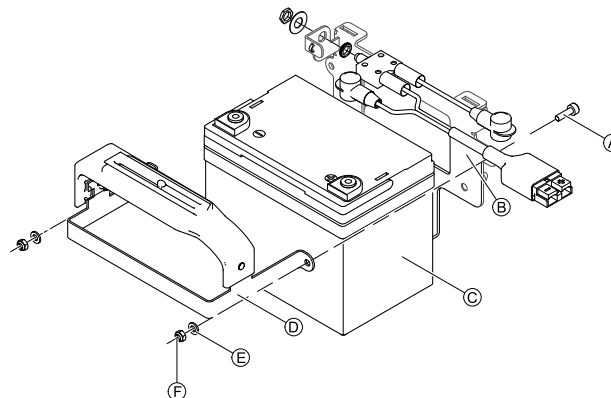

Fig. 7-3

Removing Batteries

1. Turn off power.
2. Bring seat into service position. See 7.10.1 *Moving Seat Into Service Position / Removing Seat*, page 44.

3. Remove battery boxes. See 7.8.4 *Installing / Removing Battery Boxes*, page 30.
4. Remove handle and shroud of battery box. See 7.7.2 *Battery Shroud*, page 27.
5. Loosen and remove bolt (A), washer (E) and nut (F) on both sides of battery (C).
- 6.

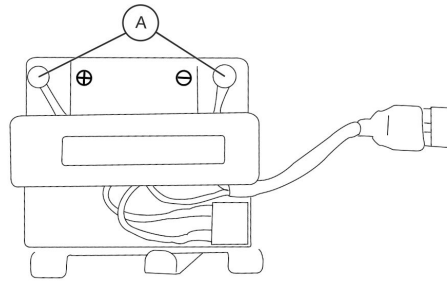

Fig. 7-4

Disconnect cable harness from battery by removing terminal screws and nuts (A).

7. Remove mounting brackets (B) and (D) together with cable harness from battery (C).
8. If necessary, remove cable tie.
9. Repeat all steps for second battery.

Installing batteries

1. Set new battery (C) on plate of mounting bracket (B).
2. Reinstall mounting bracket (D) and secure it with bolts (A), washers (E) and nuts (F) on both sides of battery.
- 3.

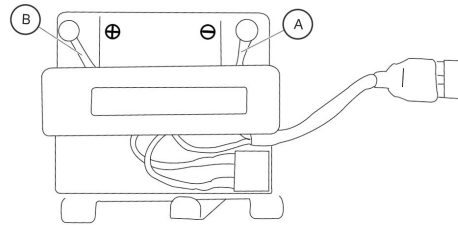

Fig. 7-5

Connect cable harness to battery.

(-)	BLUE / BLACK	Cable (A) to battery terminal (-)
(+)	RED	Cable (B) to battery terminal (+)

4. If necessary, install new cable tie.
5. Reinstall shroud of battery box. See 7.7.2 *Battery Shroud*, page 27.
6. Reinstall battery box. See 7.8.4 *Installing / Removing Battery Boxes*, page 30.
7. Repeat all steps for second battery.
8. Fold seat forward. Make sure that safety latches engage on centre post.
9. Test all functions.

7.8.4 Installing / Removing Battery Boxes

Installation of battery boxes into mobile device is described in user manual.

7.8.5 Handling Damaged Batteries Correctly



CAUTION!

Corrosion and burns from acid leakage if batteries are damaged

– Remove clothes that have been soiled by acid immediately.

After contact with skin:

– Immediately wash affected area with lots of water.

After contact with eyes:

– Immediately rinse eyes under running water for several minutes; consult a physician.

- Always wear safety goggles and appropriate safety clothing when handling damaged batteries.
- Place damaged batteries in an acid-resistant receptacle immediately after removing them.
- Only ever transport damaged batteries in an appropriate acid-resistant receptacle.
- Wash all objects that have come into contact with acid with lots of water.

Disposing of Dead or Damaged Batteries Correctly

Dead or damaged batteries can be given back to your provider or directly to Invacare.

7.8.6 Replacing remote



Replacing remote is very easy and is not described in detail. However, when replacing a remote in connection with power module, take into account the final selection of drive program. See *7.8.7 Drive Program Selection After Component Replacement, page 31*.

7.8.7 Drive Program Selection After Component Replacement

The drive program is saved in the remote, and also in the power module. If one of these two components is replaced, the system must be told which of the components has not been replaced so that it knows which contains the current controller profile.



The system allows normal usage of the mobility device after component replacement only if the profile is selected afterwards.



For details, see corresponding remote manual.

7.8.8 Updating driving program



CAUTION!

Every alteration to the drive program can influence handling and tipping stability of mobility device.

- Alterations to drive program must only be carried out by trained Invacare® providers.
- Invacare® can only assume a warranty for safe handling of mobility device – in particular tipping stability - for unaltered standard drive programs.

7.8.9 Checking Cables

1. Turn off power.
2. Remove rear shroud. See *7.7.1 Rear Shroud, page 26*.
3. Check all cables for visible damage, crushing points or abrasion points.
4. Replace damaged cables.
5. Pull on each plug carefully. The plug must not come out of its socket when pulled on lightly.
6. If a plug is loose, apply slight pressure to push the plug into the socket. The plug must snap in place securely.
7. Check that plug is firmly attached to its socket.
8. Remove batteries. See *7.8.2 Batteries, page 28*.
9. Check battery cables for visible damage, crushing points or abrasion points.
10. Replace damaged cables.
11. Install parts in reverse order.
12. Test all functions.

7.8.10 Resetting Circuit Breaker

If the mobility device cannot be turned on, check whether the safety cutout has triggered. The safety cutout is reset by pressing the knob inwards.

See user manual.

7.9 Wheels

7.9.1 Tyre Pressure



CAUTION!

Risk of damage to rim and tyre when tyre pressure is exceeded

- Observe recommended tyre pressure.

For recommended tyre pressure see inscription on tyre, rim, or contact Invacare. Compare table below for conversion.

psi	bar
22	1.5
23	1.6
25	1.7
26	1.8

psi	bar
28	1.9
29	2.0
30	2.1
32	2.2
33	2.3
35	2.4
36	2.5
38	2.6
39	2.7
41	2.8
42	2.9
44	3.0

7.9.2 Tyre Types

There are three different types of tyres or inner tubes, and specific points must be observed for the replacement of each type. The individual types of tyres can be easily distinguished:

- Pneumatic tyres have black valve caps.
- Puncture-protected tyres have red valve caps.
- Puncture-proof tyres have no valves.









There are five chapters about tyre repair and wheel replacement:

- *Replacing Drive Wheel (5-Screw Installation)*
- *7.9.5 Replacing Drive Wheel (1-Bolt Installation), page 35*
- *7.9.7 Replacing Castor Wheel on Double-Sided Fork, page 37*
- *Replacing Castor Wheels on Single-Sided Fork*
- *7.9.8 Replacing Tyres, page 39* deals with tube repair and replacing solid tyres.

 Not all chapters are necessarily contained in this manual.

 Specific tightening torques for wheels and rim halves are listed in *7.9.3 Specific Tightening Torques, page 32*.

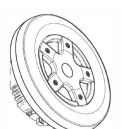
7.9.3 Specific Tightening Torques

	Drive Wheels								
	10" x 3"	12 1/2" x 2 1/4"			14"				
									
Wheel Fixation	70 Nm	70 Nm	33 Nm	35 Nm	70 Nm	33 Nm	60 Nm	25 Nm	18 Nm
Rim Halves	25 Nm	25 Nm	10 Nm	25 Nm	25 Nm	10 Nm	25 Nm	25 Nm	18 Nm











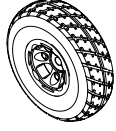

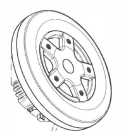

	Castor Wheels									
	6"		8"				9"		10"	
Wheel Fixation	18 Nm	18 Nm	25 Nm	16 Nm	16 Nm	25 Nm	25 Nm	25 Nm	18 Nm	100 Nm
Rim Halves	10 Nm	25 Nm	5 Nm	—	—	—	25 Nm	5 Nm	25 Nm	25 Nm

7.9.4 Overview of Power Wheelchair Models and Wheel Types













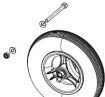

























- Not all wheel types are available for all power wheelchairs, see footnotes.
- The symbols indicate three tyre types:

pneumatic = black valve cap	puncture-protected = red valve cap	puncture-proof = no valve

Models	Drive wheels								
	10" x 3"	12 1/2" x 2 1/4"			14"				
	4-Spoke Rim (1-Bolt Installation)	3-Spoke Rim (1-Bolt Installation)	5-Spoke Rim (1-Bolt Installation)	5-Spoke Plastic Rim (1-Bolt Installation)	3-Spoke Rim (1-Bolt Installation)	5-Spoke Rim (1-Bolt Installation)*	5-Spoke Rim (5-Screw Installation)	5-Spoke Rim for True Track*	Solid Rim (5-screw installation)
TDX SP2									
Storm ⁴ Series									
Kite									
Bora									
Fox									
Stream									
Mirage									

Models	Drive wheels								
	10" x 3"	12 1/2" x 2 1/4"			14"				
									
4-Spoke Rim (1-Bolt Installation)	3-Spoke Rim (1-Bolt Installation)	5-Spoke Rim (1-Bolt Installation)	5-Spoke Plastic Rim (1-Bolt Installation)	3-Spoke Rim (1-Bolt Installation)	5-Spoke Rim (1-Bolt Installation)*	5-Spoke Rim (5-Screw Installation)	5-Spoke Rim for True Track*	Solid Rim (5-screw installation)	
Dragon			 						
Pronto M41									
AVIVA RX									  

* For wheelchair-specific mounting instruction, see respective manual.

Models	Castor Wheels									
	6"	8"				9"			10"	
										
Single-Sided/Double-Sided Fork	Double-Sided Fork				Single-Sided/Double-Sided Fork	Double-Sided Fork	Single-Sided/Double-Sided Fork	Double-Sided Fork	Single-Sided Fork	
TDX SP2										
Storm ⁴ Series									  	  
Kite						 			  	  
Bora				 			 			
Fox										
Stream										
Mirage			 							
Dragon										

Models	Castor Wheels									
	6"		8"				9"		10"	
	Single-Sided/ Double-Sided Fork	Double-Sided Fork				Single-Sided/ Double-Sided Fork	Double-Sided Fork	Single-Sided/ Double-Sided Fork	Double-Sided Fork	Single-Sided Fork
Pronto M41	■									
AVIV-A RX						■		□ ■ ■		

* For wheelchair-specific mounting instruction, see respective manual.

7.9.5 Replacing Drive Wheel (1-Bolt Installation)

This chapter deals with drive wheels that are installed with one central bolt.



CAUTION!
Risk of Crushing to Hands and Feet by Weight of Mobility Device
 – Pay attention to hand and feet.
 – Use proper lifting techniques.



CAUTION!
Risk of Uncontrolled Movement of Mobility Device
 – Turn off power supply (ON/OFF key).
 – Engage drive.
 – Before raising mobility device, secure wheels by blocking them with wedges.
 – Prevent the mobility device tipping by propping it up on a wooden block which is long and wide enough under the battery case. If the wooden block is too short or too high, the mobility device can still tip.



- 19 mm wrench
- Flat screwdriver
- Tightening kit
- Oblong wooden blocks (at least 14 x 14 x 30 cm)

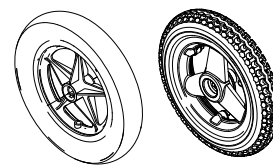

Removing Wheel

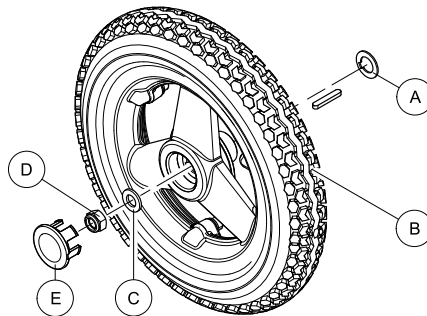

Fig. 7-6

1. Remove plastic cap ⑤.
2. Loosen and remove nut ④ and washer ③.
3. Remove wheel ② from axle.
4. Remove remaining washer ①.

Installing Wheel

1. Install parts in reverse order.
2. When installing wheel, pay attention to correct direction of rotation.
3. Tighten nut to prescribed torque. See 7.9.3 *Specific Tightening Torques*, page 32.

Replacing Wheel (10" x 3")



- 19 mm wrench
- Oblong wooden blocks (at least 14 x 14 x 30 cm)

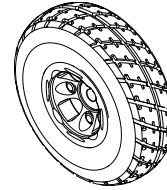

Removing Wheel

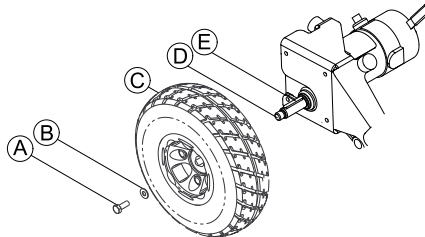

Fig. 7-7

1. Loosen and remove nut (A) and washer (B).
2. Remove wheel (C) from drive shaft (D). If necessary, use wheel puller to remove wheel from drive shaft.

Installing Wheel

1. Apply anti-seize compound to drive shaft (D) and keystone (E).

! Do not apply more than one-inch (25.4 mm) (in length) thin film of anti-seize compound to the drive shaft. Applying more than one-inch (25.4 mm) (in length) can cause the anti-seize compound to leak resulting in damage to flooring (carpet, tile, etc.).

2. When installing wheel, pay attention to correct direction of rotation.
3. Align keystone in drive shaft with cutout in wheel hub and position wheel on drive shaft.



Ensure keystone in cutout on drive shaft. Keystone must line up with wheel hub cutout.

4. Tighten nut to prescribed torque. See 7.9.3 *Specific Tightening Torques*, page 32.

7.9.6 Replacing Manual Wheel Lock



- 5 mm Allen key

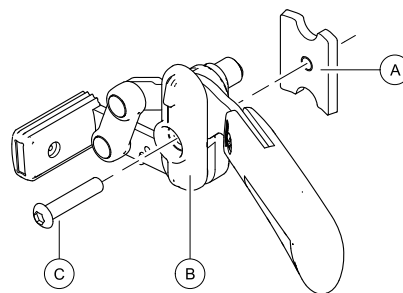

Fig. 7-8

Removing Manual Wheel Lock

1. Bring seat into service position. See 7.10.1 *Moving Seat Into Service Position / Removing Seat*, page 44.
2. Disengage wheel lock (B).
3. Loosen and remove screw (C).
4. Remove wheel lock (B) and clamping plate (A) from chassis.

Installing Manual Wheel Lock

1. Install parts in reverse order.
2. Make sure that clamping plate (A) is firmly fixed.
3. Test all functions.

7.9.7 Replacing Castor Wheel on Double-Sided Fork



- 5 mm Allen key
- 13 mm wrench
- Oblong wooden block (at least 14 x 14 x 30 cm)



- 13 mm wrench (2x)
- Oblong wooden block (at least 14 x 14 x 30 cm)



- 6 mm Allen key
- 13 mm wrench
- Oblong wooden block (at least 14 x 14 x 30 cm)

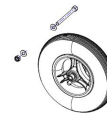

- 6 mm Allen key
- 13 mm wrench
- Oblong wooden block (at least 14 x 14 x 30 cm)



- 5 mm Allen key
- Oblong wooden block (at least 14 x 14 x 30 cm)



- 5 mm Allen key
- 13 mm wrench
- Oblong wooden block (at least 14 x 14 x 30 cm)



Removing Wheel

1. Place wooden block underneath mobility device and prop up mobility device.
2. Remove end-caps from bolt and nut (if applicable).
- 3.

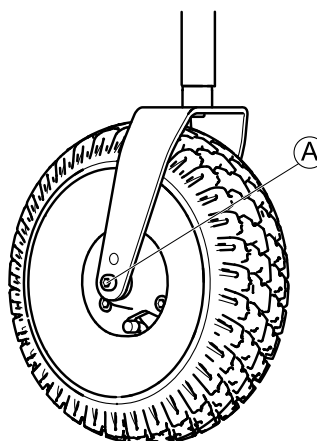

Fig. 7-9

Remove nut from bolt (A).

4. Remove bolt and wheel from fork.

Installing Wheel

1. Install parts in reverse order.
2. When installing wheel, pay attention to correct direction of rotation.
3. Tighten nut to prescribed torque. See 7.9.3 *Specific Tightening Torques*, page 32.

Replacing Castor Wheel (Aviva RX and Storm⁴ Max)



- 5 mm Allen key (up to August 2016)
- TX40 Torx key (starting August 2016)
- Oblong wooden block (at least 14 x 14 x 30 cm)

Removing Wheel

1. Loosen and remove bolts (A).
- 2.

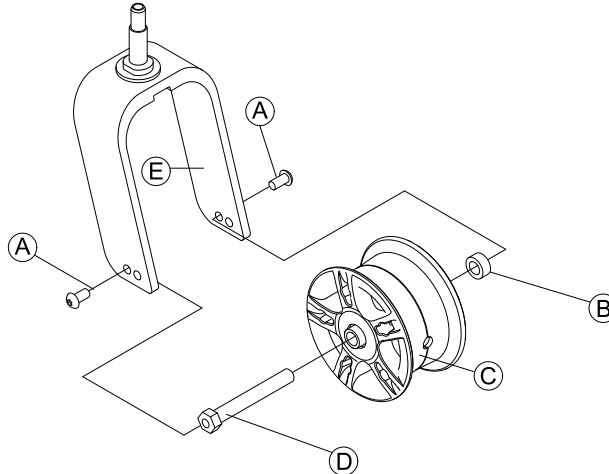

Fig. 7-10

Pull wheel (C) including axle (D) and bushing (B) out of fork (E).

Installing Wheel



CAUTION!

Risk of injury from wheels coming loose

If wheels are insufficiently secured during mounting, it can come loose when driving.

- When mounting wheels tighten bolts with prescribed torque.
- Secure all bolts using a suitable blocker.
- Never use normal nuts instead of self-locking nuts.
- Always use new nuts and bolts with an undamaged coating.

1. Install parts in reverse order. Pay attention to correct direction of rotation when installing wheels.
2. Test all functions.

Replacing Castor Wheel (6 inch wheel)



- 2 x 7/16 inch wrench
- Oblong wooden block (at least 14 x 14 x 30 cm)



Removing Wheel

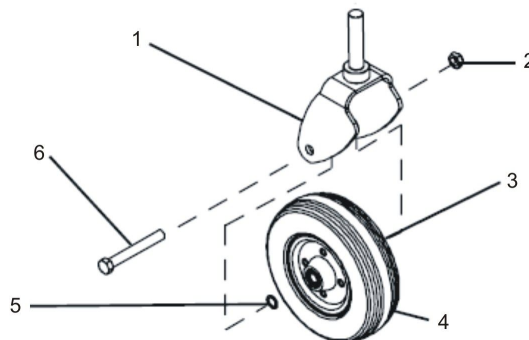

Fig. 7-11

1. Loosen nut (2).
2. Remove screw (6).
3. Remove two washers (3) and (5).
4. Remove wheel (4).
5. Replace any defective parts.

Installing Wheel

1. Install parts in reverse order.
2. When installing wheel, pay attention to correct direction of rotation.
3. Tighten nut to prescribed torque. See 7.9.3 *Specific Tightening Torques*, page 32.

7.9.8 Replacing Tyres

Repairing Pneumatic and Puncture-Protected Tyres



- 6 mm Allen key
- Tightening kit
- Oblong wooden block (at least 12 x 12 x 30 cm) for propping up mobility device
- Repair kit for tyre repair or a new inner tube
- Talcum powder
- Tyre pump or compressor



WARNING!

Risk of Injury

- If tyre with one or more damaged rim threads is inflated, rim could burst and cause serious injury.
- Do not inflate tyre if one or more rim threads are damaged.
 - Immediately replace rim with damaged threads.



WARNING!

Risk of Explosion

- There is considerable pressure in the tyre. Risk of injury. Parts can be thrown out and injure you if you do not secure rim halves.
- Secure rim halves with joiner's clamps.



Risk of Damage to Rim Threads

- Incorrectly tightened screws can cause damage to rim threads.
- Tighten rim screws with prescribed tightening torque.

1. Remove wheel as described in respective chapter in this manual.



CAUTION!

Risk of Damage by Gel When Repairing Puncture-Protected Tyres With Red Valve Caps

- Valve can become blocked by the puncture protection gel and get unusable.
- During following work you should always hold up valve so that puncture protection gel cannot enter valve.

2. Remove valve cap.
3. Let air escape completely out of tyre by firmly pressing in pin in the centre of valve.



CAUTION!

Risk of Explosion

- The wheel explodes if air pressure has not been released from wheel before wheel rim is removed.
- Always let all air out of tyre before removing rim.

- 4.

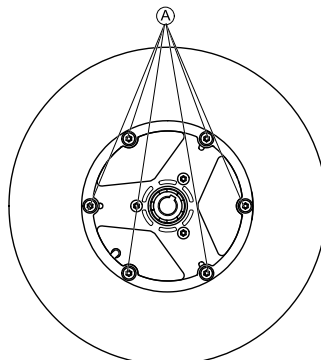

Fig. 7-12 This picture is an example.

Remove screws Ⓐ on inside of wheel.

5. Remove rim halves from wheel.
6. Remove inner tube from tyre.
7. Repair inner tube and re-fit it, or replace it with a new one.



If old inner tube has been repaired and is to be used again, and became wet during repair, it is easier to replace it if it is lightly dusted with talcum powder beforehand.

8. Install tyre in reverse order.
9. Apply rim halves to wheel.
10. Inflate tyre a little.
11. Place screws in wheel rim and tighten screws with prescribed torque. Make sure that inner tube is not clamped between wheel rim halves.
12. Make sure that tyre is contacting wheel rim directly.
13. Inflate tyre to prescribed pressure.
14. Make sure that tyre is still closely contacting wheel rim.
15. Screw valve cap on.
16. Install wheels according to instruction. See respective chapter.

Repairing Solid Tyre



- 6 mm Allen key
- 3 joiner's clamps with plastic caps



Risk of Damage to Rim Threads

- Incorrectly tightened screws can cause damage to rim threads.
– Tighten rim screws with prescribed tightening torque.

1. Remove wheel as described in respective chapter in this manual.
2. Secure rim halves against unexpected discharge with three joiner's clamps. When doing so, make sure that you do not scratch rims.
- 3.

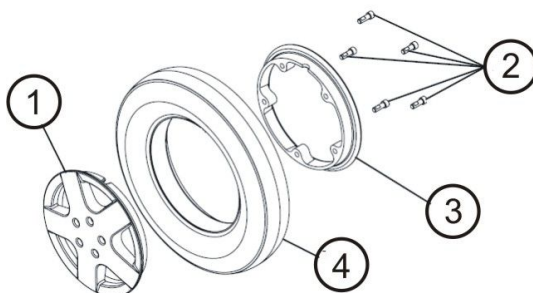

Fig. 7-13

- Loosen and remove screws (2) on inside of wheel.
4. Loosen joiner's clamps carefully and alternately until you can remove rim halves without risk.
5. Remove inner (3) and outer (1) half of rim from tyre (4).
6. Replace any defective or worn parts.
7. Install tyre in reverse order.
8. When fitting rim halves together, make sure that drill holes and threads for screws are placed exactly on top of each other.
9. Place joiner's clamps in position.
10. Tighten joiner's clamps alternately in small stages until rim halves are precisely aligned.
11. Install and tighten screws.
12. Remove joiner's clamps.
13. Install wheel as described in respective chapter in this manual.

7.9.9 Replacing Front Fork



- 19 mm wrench
- Oblong wooden block (approx. 14 x 14 x 30 cm)
- Flat screwdriver (large)

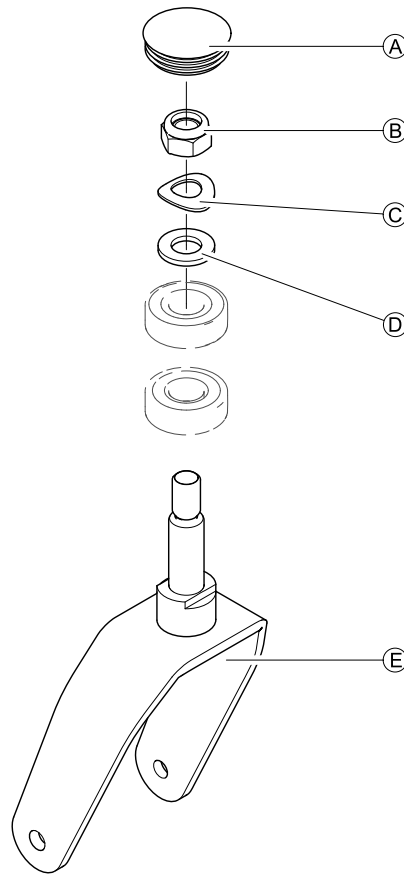

Fig. 7-14

Removing Fork

1. Remove plastic cap (A).
2. Loosen and remove nut (B), curved spring washer (C) and plain washer (D).
3. Pull fork (E) out of steering head.

Installing Fork

1. Install parts in reverse order.
2. Test all functions.

7.9.10 Replacing Caster Locks



CAUTION!

Incorrect installation can cause steering wheels to fall out.

Make sure to mount caster locks on the correct side.

- Follow instructions precisely.
- Pay attention to marks on caster locks. Marks are LH (left-hand) and RH (right-hand).



- Phillips screwdriver, size 2
- Torque wrench
- Wooden block (approx. 12 x 12 x 30 cm)



- When removing, take care of small parts such as screws and washers. Put all small parts down so that they can be installed in correct sequence.
- Use proper lifting techniques so that swinging axle is hanging free or remove swinging axle, see 7.5.2 *Replacing / Reversing Swinging Axle*, page 22, and place swinging axle in a bench vice.

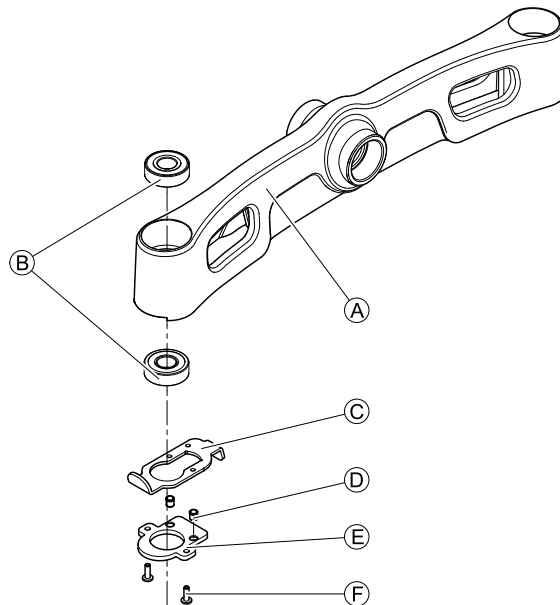

Fig. 7-15



Removing Caster Lock

1. Remove legrests and other parts that are in the way.
2. Unlock caster locks © for front wheels on swinging axle ①.
3. Remove front fork. See 7.9.9 *Replacing Front Fork*, page 40.
4. Loosen and remove screws ⑥, locking plate ⑤ and spring—loaded thrust pins ④.
5. Remove caster lock ③.

Installing Caster Lock

1. Install parts in reverse order.
2. Test all functions.

7.9.11 Replacing Anti-Tipper Wheels

-  • 6 mm Allen key
-  • 13 mm wrench

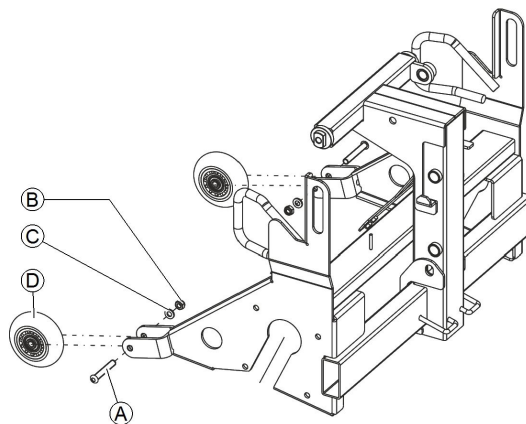

Fig. 7-16

Removing Anti-Tipper Wheel

1. Loosen and remove nut ②, washer ③ and bolt ①.
2. Remove wheel ④.
3. Replace anti-tipper wheel.

Installing Anti-Tipper Wheel

1. Install parts in reverse order.
2. Tighten nut ② just tight enough that wheel can still rotate freely.

7.9.12 Replacing Steering Head Bearings on Steering Wheels



CAUTION!

Incorrect installation can damage bearings and cause steering wheels to fall out.

The single-row angular ball bearing rings are not identical on both sides. There is only one correct way to insert them.

– Follow instructions precisely.



- When removing, take care of small parts such as screws and washers. Put all small parts down so that they can be installed in correct sequence.
- Remove legrests and other parts that are in the way.
- Use proper lifting techniques so that swinging axle is hanging free or remove swinging axle, see 7.5.2 *Replacing / Reversing Swinging Axle*, page 22, and place swinging axle in a bench vice.



- Phillips screwdriver, size 2
- 19 mm wrench
- Torque wrench
- Wooden block (approx. 12 x 12 x 30 cm)

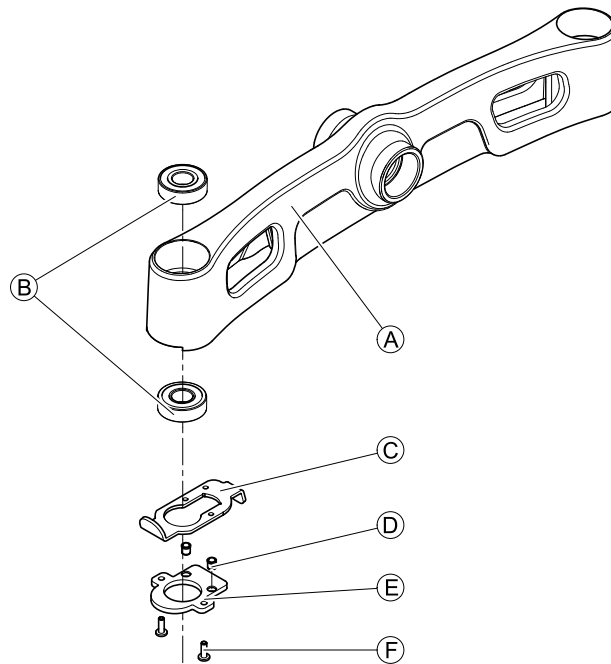

Fig. 7-17

Removing Steering Head Bearings

1. If installed, unlock caster locks © on swinging axle (A).
2. Remove front fork. See 7.9.9 *Replacing Front Fork*, page 40.
3. Loosen and remove screws (F), locking plate (E) and sprung thrust pieces (D).
4. Remove caster lock ©.
5. Remove all steering head bearings (B).

Installing Steering Head Bearings



- Insert new steering head bearing precisely. See 7.9.13 *Installing Ball Bearings*, page 44.
- Left-hand and right-hand caster locks © are different. Make sure to use correct caster lock.
- Make sure that sprung thrust pieces (D) are seated precisely in securing seat when installing.
- Tighten screws (F) with a medium-strength thread locking adhesive.

1. Install parts in reverse order.
2. If removed, install swinging axle. See 7.5.2 *Replacing / Reversing Swinging Axle*, page 22.
3. Install front fork. See 7.9.9 *Replacing Front Fork*, page 40.
4. Tighten nut to 25 Nm \pm 2 Nm.
5. Then loosen them slightly.
6. Then re-tighten to 15 Nm \pm 1.5 Nm.
7. Test all functions.

7.9.13 Installing Ball Bearings



CAUTION!

Incorrect installation can damage bearings and cause steering wheels to fall out

The single-row angular ball bearing rings are not identical on both sides. There is only one correct way to insert them.

- The bearings must always be assembled so that narrow borders of the ball bearings are facing each other (inside).
- The steering head bolts and nuts must always be pressing against wide (outside) border of ball bearings! Otherwise, the bearings will be pressed apart and damaged by the bolts.

The illustrations show the wide border of the ball bearing on outside of ball race **A** and the narrow ball bearing edge on the inside **B**.

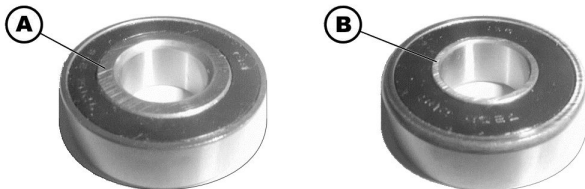

After installation wheels should rotate freely but bearings should have no play.

7.10 Seating

This manual refers to configurations with standard seat system.

For other seat systems (for example Modulite), refer to the corresponding manual.

7.10.1 Moving Seat Into Service Position / Removing Seat

It is necessary to move seat into service position or to remove it for maintenance purposes or if batteries have to be removed.

- Secure mobility device against rolling away by pressing manual wheel lock down.
- Remove legrests.

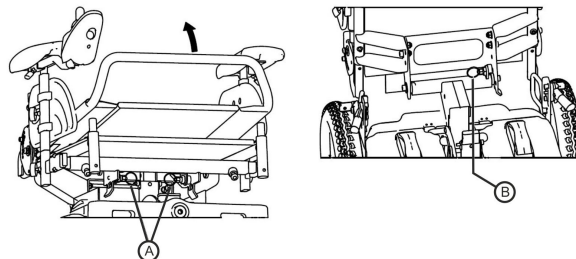

Fig. 7-18

Removing Seat / Moving Seat Into Service Position

1. Pull safety latches **A** on centre column to unlock seat.
2. Fold seat backwards until rear safety latch **B** engages on rear post. Seat is now in service position.
3. If you need to remove seat, pull safety latch **B** on rear post and tilt seat into vertical position.
4. Remove seat.

Installing Seat

1. Place seat vertically onto its holder again.
2. Fold seat forward.
3. Make sure safety latches **A** on centre post engage.

7.10.2 Replacing Seat Frame (Fox Seat)



- Phillips screwdriver, size 2
- 5 mm Allen key
- 6 mm Allen key
- Side cutting pliers
- Cable ties

- i** When removing, take care of small parts such as screws and washers. Put all small parts down so that they can be installed in correct sequence.

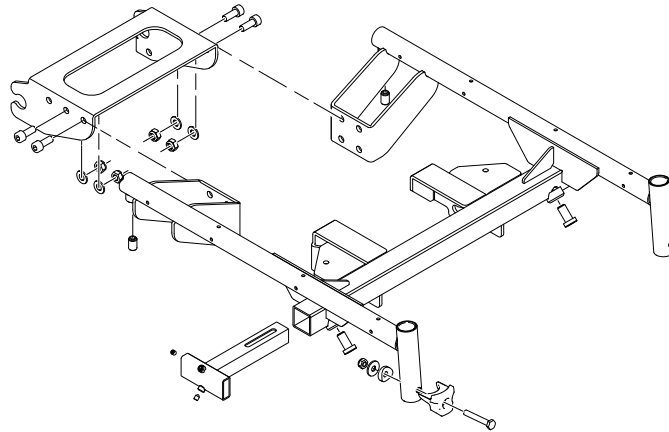

Fig. 7-19

Removing Seat Frame

1. Remove any tie wraps which may have been fitted to hold cable away from remote. Remove cable from glued terminals. Remove cable so that there is no cable connection between seat and chassis.
2. Remove remote and keep it in a safe place.
3. Remove legrests.
4. Remove armrests. See 7.13.1 *Replacing Armrest*, page 50.
5. Remove armrest holder. See 7.13.3 *Replacing Armrest Holder*, page 51.
6. Remove seat from chassis. See 7.10.1 *Moving Seat Into Service Position / Removing Seat*, page 44.
7. Remove fabric seat or seat plate. See 7.10.3 *Replacing Fabric Seat (Padded)*, page 46, 7.10.4 *Replacing Fabric Seat (Stretched)*, page 46 or 7.10.5 *Replacing Seat Plate*, page 47.
- 8.

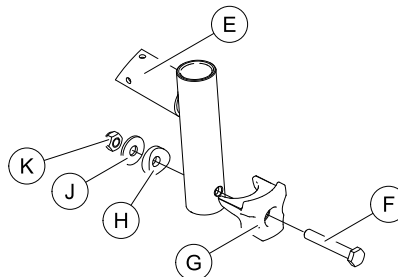

Fig. 7-20

Loosen and remove bolts **F**, fixing **G**, saddle washer **H**, washer **I** and nut **K** from legrest holder on both sides.

9. Remove backrest unit. See 7.12 *Backrest*, page 49.
- 10.

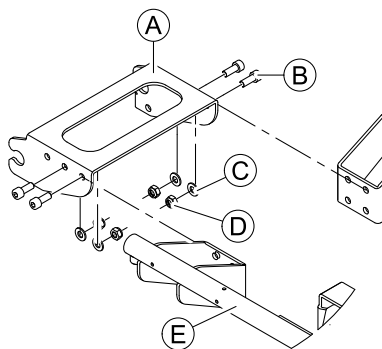

Fig. 7-21

Loosen and remove bolts **B**, washers **C** and nuts **D** on both sides.

11. Remove seat frame **E** from seat support **A**.
12. Replace seat frame or seat support.

Installing Seat Frame

1. Install parts in reverse order.

i When installing, ensure that saddle washer **H** is in the correct position.

2. Check all functions of the vehicle and go for a test drive.

7.10.3 Replacing Fabric Seat (Padded)

-  • Phillips screwdriver, size 2

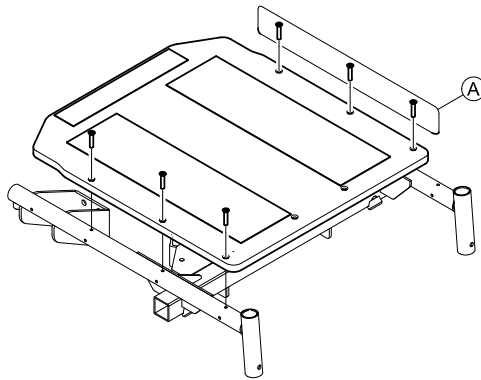

Removing fabric seat

 In older revisions of the seat, the last bolt on each side adjust the backrest adapter. This seat can look different to the image above.



1. Remove seat cushion.
2. Remove armrests. See 7.13.1 *Replacing Armrest*, page 50.
3. Loosen and remove six (eight) screws (A).

Installing fabric seat

 When installing, ensure that the saddle washer is in the correct position.

1. Install parts in reverse order.
2. Test all functions.

7.10.4 Replacing Fabric Seat (Stretched)

-  • Phillips screwdriver, size 2
-  • 8 mm wrench

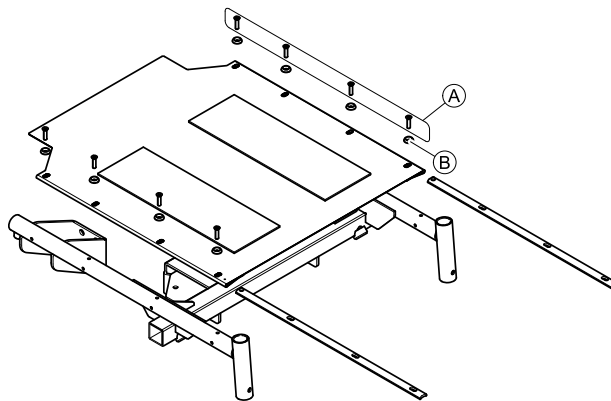

Fig. 7-22

Removing Fabric Seat

1. Loosen and remove eight screws (A) including rosette (B).
2. Replace fabric seat.

Installing Fabric Seat

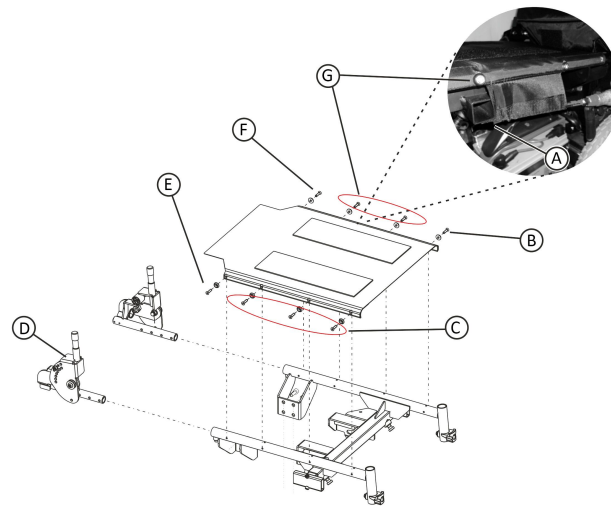



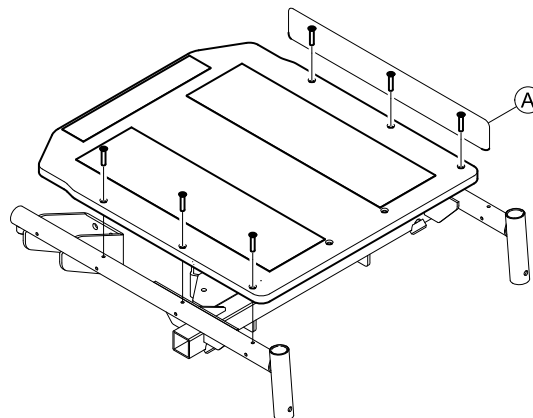

Fig. 7-23

1. Position backrest mounting bracket **D** according to seat depth, so that holes of bracket and seat frame are in line. See *5.4 Adjusting Seat Depth via Backrest Unit, page 11*.
2. Slightly tighten set screws hand-tight.
3. Insert four screws (**C** and **E**) on right side of seat frame. Do not tighten screws completely.
4. Tighten textile seat using a large screwdriver or a similar tool, by pressing the screwdriver in the flap against chassis **A**.
5. Insert two middle screws **G** and after then outer screws **B** and **F** including rosette and tighten them to 6 Nm.
6. After this, tighten four screws **C** and **E** to 6 Nm.
7. Tighten set screw.
 -  Screws **E** and **F** are also used to adjust seat depth via backrest unit **D**. See *5.4 Adjusting Seat Depth via Backrest Unit, page 11*.
8. Push flap under seat frame.
9. Install armrests. See *7.13.1 Replacing Armrest, page 50*.
10. Test all functions.

7.10.5 Replacing Seat Plate

-  • Phillips screwdriver, size 2
-  • 8 mm wrench





Removing seat plate

1. Remove seat cushion.
2. Remove armrests. See *7.13.1 Replacing Armrest, page 50*.
3. Loosen and remove screws **A**.
4. Lift seat plate from seat frame.
5. Replace seat plate or install fabric seat if required. See *7.10.3 Replacing Fabric Seat (Padded), page 46* and *7.10.4 Replacing Fabric Seat (Stretched), page 46*.

Installing seat plate

1. Install parts in reverse order.
2. Test all functions.

7.10.6 Replacing Safety Latch

-  • 19 mm wrench
-  • 12 mm wrench

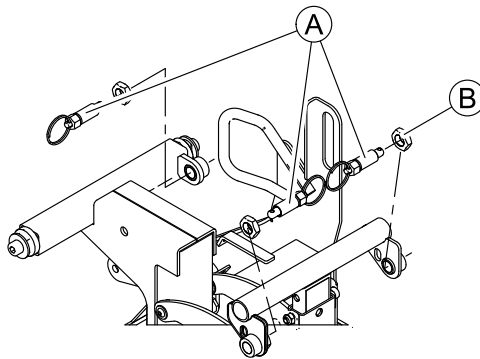

Removing safety latch

1. Remove seat frame. See 7.10.2 *Replacing Seat Frame (Fox Seat)*, page 44.
2. Loosen adjusting nut **B**.
3. Unscrew safety latch **A** and replace it.

Installing safety latch

1. Install parts in reverse order.
2. Screw in safety latch **A** and adjust it. See 5.8 *Adjusting Safety Latch*, page 15.

7.11 Headrest/Neckrest

7.11.1 Replacing Rea Headrest

Removing Headrest

1. Loosen hand screw **B**.
2. Pull headrest **A** out of bracket **C**.

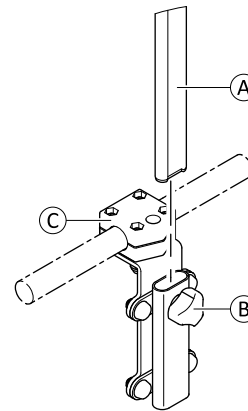



Fig. 7-24

Installing Headrest

1. Install parts in reverse order.
2. Tighten hand screw **B** hand-tight.
3. Test all functions.

7.11.2 Replacing Rea Headrest Mounting Bracket (Sling Backrest)

-  • 4 mm Allen key

Removing Bracket

-  Not all bolts and washers are shown in illustration.

1. Loosen and remove bolts (E) including washers (F), mounting plate (D) and bottom side of bracket (C).
2. Remove top side of bracket (B) including nuts (A).

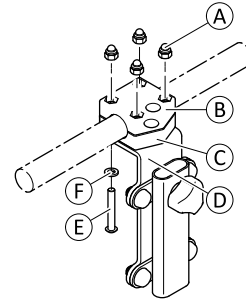

Fig. 7-25

Installing Bracket

1. Install parts in reverse order.
2. Test all functions.

7.12 Backrest

7.12.1 Replacing Standard Backrest



- Phillips screwdriver, size 2

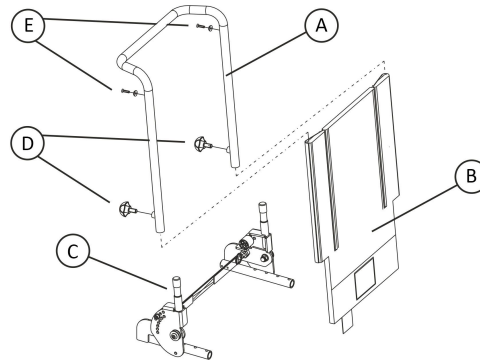

Removing backrest unit

1. Loosen hand screws (D).
2. Pull the backrest tube (A) from backrest holder (C).
3. Loosen and remove screws (E) including washers.
4. Remove hand screws (D).
5. Pull off sling (B) from backrest tube (A).
6. Replace backrest holders. See 7.12.2 *Replacing Backrest Holder With Quick Release System*, page 49.

Installing backrest unit

1. Install parts in reverse order.
2. Test all functions.

7.12.2 Replacing Backrest Holder With Quick Release System



- Phillips screwdriver, size 2
- 5 mm Allen key
- 12 mm wrench
- 13 mm wrench
- 19 mm wrench



When removing, take care of small parts such as screws and washers. Put all small parts down so that they can be installed in correct sequence.

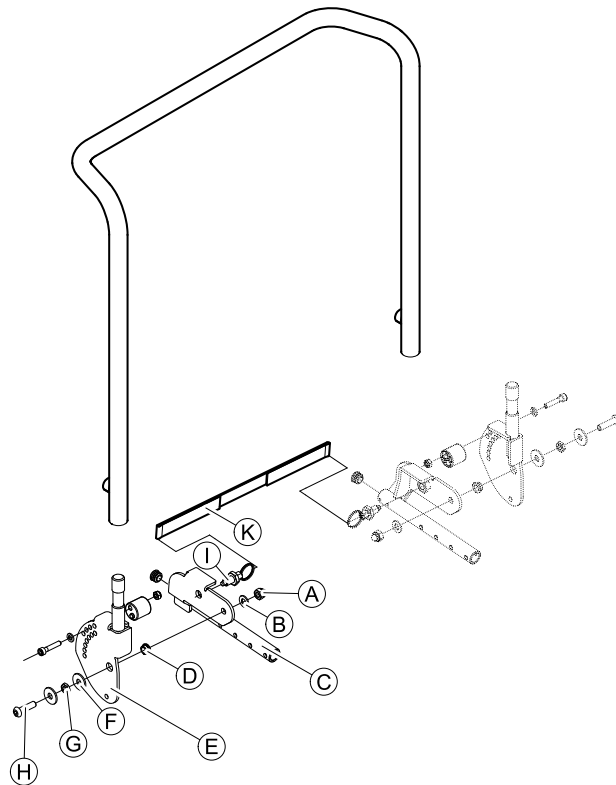

Fig. 7-26

Removing Backrest Holder

1. Remove backrest unit. See 7.12.1 *Replacing Standard Backrest*, page 49.
2. Loosen and remove nut (A) and washer (B).
3. Remove bolt (H), nut (G), washers (F) and bushing (D).
4. Pull quick release cord (K) to unlock backrest holder (E).
5. Remove backrest holder (E) including quick release cord (K).
- 6.

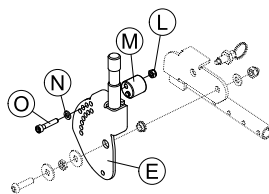

Fig. 7-27

Loosen and remove nut (L), stopper (M), washer (N) and bolt (O).

7. Remove safety latch. See 7.10.6 *Replacing Safety Latch*, page 48.
8. Repeat steps two to seven for the other side.

Installing Backrest Holder

1. Install parts in reverse order.
2. Install backrest unit. See 7.12.1 *Replacing Standard Backrest*, page 49.
3. Test all functions.

7.13 Armrests

7.13.1 Replacing Armrest



- 6 mm Allen key

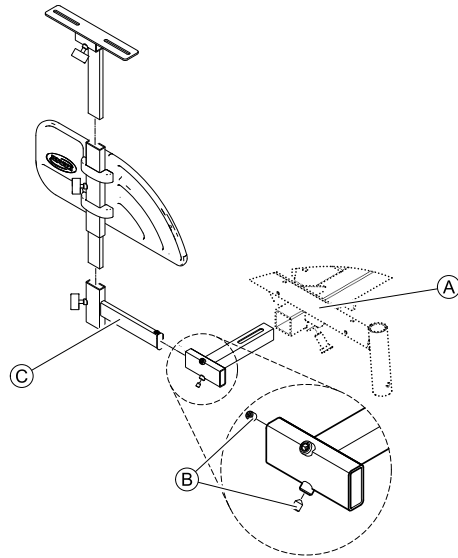

Removing armrest

1. Loosen two screws (B).
2. Pull armrest (C) out of the holder.

Installing armrest

1. Install parts in reverse order.
2. Test all functions.

7.13.2 Installing Inrigged Armrest (Wooden Seat Plate)



- 3 mm Allen key



You must insert a spacer when mounting inrigged armrests to a wooden seat plate.

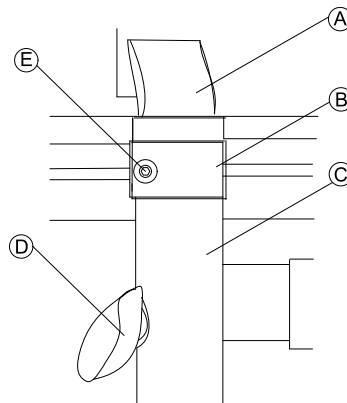

Fig. 7-28

1. Stick spacer (B) to bracket (A).
2. Tighten screw (E).
3. Insert bracket (A) into tube (C).
4. Tighten screw (D).

7.13.3 Replacing Armrest Holder



- 10 mm Allen key

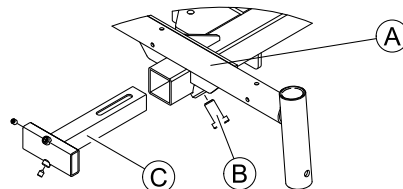

Fig. 7-29

Removing Holder

1. Loosen screw ②.
2. Pull holder ③ out of seat frame ①.
3. Replace holder.

Installing Holder

1. Install parts in reverse order.
2. Test all functions.

7.14 Replacing Foot Plate / Heel Strap of Legrest

-  • 6 mm Allen key
• Phillips screwdriver, size 2

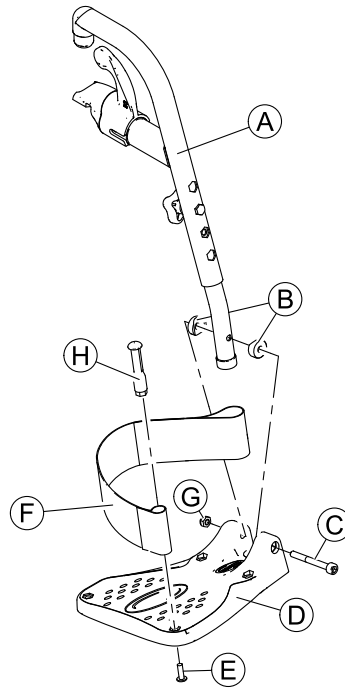



Fig. 7-30

Removing Foot Plate / Heel Strap

1. Loosen and remove screw ③, saddle washers ② and nut ④.
2. Pull legrest ① out of foot plate ⑤.
3. Loosen and remove screw ⑥ including plastic bolt ⑧.
4. Remove heel strap ⑦.

Installing Foot Plate / Heel Strap

1. Install parts in reverse order.
 -  Ensure that saddle washers ② are in correct position.
2. Test all functions.

7.15 Posture Belt

7.15.1 Replacing Posture Belt

-  • 5 mm Allen key
• 13 mm wrench

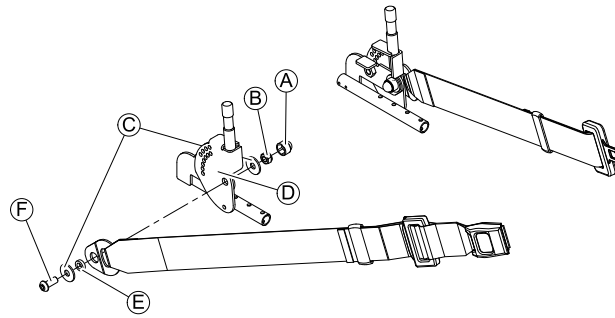

Fig. 7-31

Removing Posture Belt

1. Remove plastic cap **A**.
2. Loosen and remove bolt **F** nut **B**, washers **C** and distance bushing **E**.
3. Remove posture belt.
4. Repeat all steps on other side.

Installing Posture Belt

1. Install parts in reverse order.
2. Test all functions.

7.16 Lighting Unit

7.16.1 Replacing Headlight

Replacing Headlight

See corresponding light manual.

Removing Headlight Holder

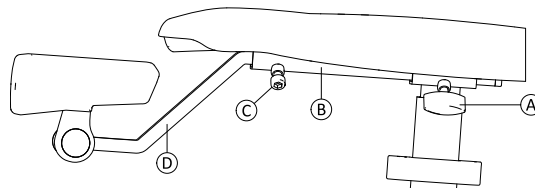

Fig. 7-32

1. Loosen screw **C**.
2. Pull holder **D** out off remote bracket **B**.
3. If necessary, loosen hand screw **A** and remove remote bracket **B**.

Installing Headlight Holder

1. Install parts in reverse order.
2. Test correct installation.

7.16.2 Replacing Rear Light

See corresponding light manual.

Invacare Sales Companies

Australia:

Invacare Australia Pty. Ltd.
1 Lenton Place, North Rocks NSW
2151
Australia
Phone: 1800 460 460
Fax: 1800 814 367
orders@invacare.com.au
www.invacare.com.au

United Kingdom:

Invacare Limited
Pencoed Technology Park, Pencoed
Bridgend CF35 5AQ
Tel: (44) (0) 1656 776 222
Fax: (44) (0) 1656 776 220
uk@invacare.com
www.invacare.co.uk

Canada:

Invacare Canada L.P.
570 Matheson Blvd East, Unit 8
CDN Mississauga, On. L4Z 4G4
Phone: (905) 890 8300
Toll Free: 800.668.5324
www.invacare.ca

Eastern Europe, Middle East & CIS:

Invacare EU Export
Am Achener Hof 8
D-88316 Isny
Tel: (49) (0)7562 700 397
eu-export@invacare.com
www.invacare-eu-export.com

Ireland:

Invacare Ireland Ltd,
Unit 5 Seatown Business Campus
Seatown Road, Swords, County Dublin
Tel : (353) 1 810 7084
Fax: (353) 1 810 7085
ireland@invacare.com
www.invacare.ie

New Zealand:

Invacare New Zealand Ltd
4 Westfield Place, Mt Wellington 1060
New Zealand
Phone: 0800 468 222
Fax: 0800 807 788
sales@invacare.co.nz
www.invacare.co.nz



Manufacturer:

Invacare Deutschland GmbH
Kleiststraße 49
D-32457 Porta Westfalica
Germany

