

# Invacare® Bora® / Spectra® XTR Series

en Power Wheelchair  
Service Manual



PROVIDER: Keep this manual.  
The procedures in this manual MUST be performed by a qualified  
technician.



**Yes, you can.®**

© 2020 Invacare Corporation

All rights reserved. Reproduction, duplication or modification in whole or in part is prohibited without prior written permission from Invacare. Trademarks are identified by ™ and ®. All trademarks are owned by or licensed to Invacare Corporation or its subsidiaries unless otherwise noted.

Making Life's Experiences Possible is a registered trademark in the U.S.A.

# Contents

<b>1 General</b> .....	<b>4</b>
1.1 Introduction .....	4
1.2 General Information .....	4
1.3 Notes on Shipping .....	4
1.4 Symbols in this Manual .....	4
1.5 Images in This Manual .....	5
<b>2 Safety</b> .....	<b>6</b>
2.1 Safety information .....	6
2.2 Safety and Fitting Instructions .....	6
<b>3 Hygiene</b> .....	<b>8</b>
3.1 Handling of Returned Used Products .....	8
<b>4 Setup</b> .....	<b>9</b>
4.1 General information on setup .....	9
4.2 Adjusting Seating Position .....	9
4.3 Adjusting Lower Leg Length .....	9
4.4 Adjusting Seat Depth .....	9
4.5 Adjusting Centre of Gravity of Seat .....	10
4.5.1 Modulite Seat .....	11
4.5.2 Telescopic Seat Frame .....	12
4.5.3 One-Piece Seat Plate .....	12
4.5.4 Mounting Position of Seat Frame .....	13
4.5.5 Seat Depth Setting .....	13
4.5.6 Check tipping stability .....	15
<b>5 Testing</b> .....	<b>16</b>
5.1 Testing Motor .....	16
5.2 Testing Motor Brake .....	16
5.3 Rain test .....	16
5.4 Field Load Test .....	17
5.5 Checking Battery Charge Level .....	17
5.6 Checking Actuator .....	18
<b>6 Service</b> .....	<b>19</b>
6.1 General Warning Information on Installation Work .....	19
6.2 Tightening Torques .....	19
6.3 Troubleshooting .....	19
6.3.1 Operational Faults .....	19
6.3.2 Drive Fault Diagnosis .....	20
6.4 Service Plan (Once a Year) .....	20
6.5 Overview Components .....	22
6.5.1 Mobility Device With Detachable Seat .....	22
6.5.2 Mobility Device With Lifter And Tilt Module .....	23
6.6 Chassis .....	25
6.6.1 Replacing Kerb Climber (L-Shape Lever) .....	25
6.6.2 Replacing Kerb Climber (T-Shape Lever) .....	26
6.7 Drive Components .....	27
6.7.1 Preparing Replacement of Drive Components .....	27
6.7.2 Overview Motor/Gearbox Unit .....	27
6.7.3 Replacing Swing Arm .....	28
6.7.4 Replacing Motor-Gearbox Unit .....	29
6.7.5 Replacing or Rotating Motor-Gearbox Unit Sealing Ring .....	31
6.7.6 Replacing Motor-Gearbox Coupling .....	32
6.7.7 Replacing Carbon Brushes .....	32
6.7.8 Replacing Engaging Turn Knob .....	34
6.8 Wheels .....	35
6.8.1 Tyre Pressure .....	35
6.8.2 Tyre Types .....	35
6.8.3 Specific Tightening Torques .....	36
6.8.4 Overview of Power Wheelchair Models and Wheel Types .....	36
6.8.5 Replacing Drive Wheel (1-Bolt Installation) .....	38
6.8.6 Replacing drive wheel hub .....	40
6.8.7 Replacing Castor Wheel on Double-Sided Fork .....	40
6.8.8 Replacing Tyres .....	43
6.8.9 Replacing Steering Head Bearings on Castors .....	44
6.8.10 Replacing manual wheel lock .....	46
6.8.11 Replacing anti-tipping mechanism with screw .....	47
6.8.12 Replacing anti-tipping mechanism with locking spring .....	47
6.8.13 Replacing defective locking spring .....	48
6.9 Shrouds .....	48
6.9.1 Replacing Front Shroud .....	48
6.9.2 Replacing fender .....	49
6.10 Controls .....	50
6.10.1 Replacing Power Module .....	50
6.10.2 Replacing G-Trac Sensor .....	51
6.10.3 Replacing Operating Hour Counter .....	51
6.10.4 Replacing Connecting Cable of Operating Hour Counter .....	53
6.10.5 Updating software .....	54
6.11 Batteries .....	54
6.11.1 Removing Battery Boxes .....	55
6.11.2 Replacing Batteries .....	55
6.11.3 Removing Batteries from Battery Tray .....	57
6.11.4 General Instructions on Handling Batteries .....	59
6.11.5 Handling Damaged Batteries Correctly .....	59
6.11.6 Main Fuse .....	59
6.11.7 Checking Cables .....	62
6.12 Lighting Unit .....	62
6.12.1 Replacing headlight (LED light) .....	62
6.12.2 Replacing Front Lamp Holder (LED Light) .....	63
6.12.3 Replacing Rear Light (LED Light) .....	63
6.13 Seating .....	64
6.13.1 Replacing Tilt Tube .....	64
6.13.2 Replacing actuator — powered tilt with fixed pivot point .....	65
6.13.3 Replacing Seat Height Adapter .....	66

# 1 General

## 1.1 Introduction

This document contains important information about assembly, adjustment and advanced maintenance of the product. To ensure safety when handling the product, read this document and the user manual carefully and follow the safety instructions.

Find the user manual on Invacare's website or contact your Invacare representative. See addresses at the end of this document.

Invacare reserves the right to alter product specifications without further notice.

Before reading this document, make sure you have the latest version. You find the latest version as a PDF on the Invacare website.

For pre-sale and user information, see the user manual.

For more information about the product, for example product safety notices and product recalls, contact your Invacare representative. See addresses at the end of this document.

## 1.2 General Information

Service and maintenance work must be carried out taking this document into account.

It is imperative that you observe safety information.

Information about operation or about general maintenance and care work on the product should be taken from service manual.

Assembly of accessories might not be described in this document. Refer to the manual delivered with the accessory. Additional manuals can be ordered from Invacare. See addresses at the end of this document.

You can find information about ordering spare parts in the spare parts catalogue.

Spare parts must match original Invacare parts. Only use spare parts which have been approved by Invacare.

The product may only be maintained and overhauled by qualified personnel.

The minimum requirement for service technicians is suitable training, such as in the cycle or orthopedic mechanics fields, or sufficiently long-term job experience. Experience in the use of electrical measuring equipment (multimeters) is also a requirement. Special Invacare training is recommended.

Alterations to the mobility device which occur as a result of incorrectly or improperly executed maintenance or overhaul work lead to the exclusion of all liability on the side of Invacare.

If you have any problems or questions contact your provider.

## 1.3 Notes on Shipping

- If the mobility device has to be shipped back to the manufacturer for major repairs, you should always use the original packaging for transport.
- Please attach a precise description of the fault.

## 1.4 Symbols in this Manual

Symbols and signal words are used in this manual and apply to hazards or unsafe practices which could result in personal injury or property damage. See the information below for definitions of the signal words.



**DANGER**

Indicates a hazardous situation that will result in serious injury or death if it is not avoided.



**WARNING**

Indicates a hazardous situation that could result in serious injury or death if it is not avoided.



**CAUTION**

Indicates a hazardous situation that could result in minor or slight injury if it is not avoided.



**IMPORTANT**

Indicates a hazardous situation that could result in damage to property if it is not avoided.



Gives useful tips, recommendations and information for efficient, trouble-free use.



Identifies required tools, components and items which are needed to carry out certain work.

## 1.5 Images in This Manual

The detailed images in this manual are given marks to identify various components. Component marks in text and operational instructions always relate to the image directly above.

## 2 Safety

### 2.1 Safety information



**WARNING!**

The procedures in this service manual, must be performed by a specialized dealer or qualified service technician.

- Do not handle this product or any available optional equipment without first completely reading and understanding these instructions and any additional instructional material such as user manuals, installation manuals or instruction sheets supplied with this product or optional equipment.



The information contained in this document is subject to change without notice.

### 2.2 Safety and Fitting Instructions

These safety instructions are intended to prevent accidents at work, and it is imperative that they are observed.

#### Before any inspection or repair work

- Read and observe this repair manual and the associated user manual.
- Observe the minimum requirements for carrying out the work (see 1.2 *General Information, page 4*).

#### Personal Safety Equipment

##### Safety shoes

The mobility device, and some of its components, are very heavy. These parts can result in injuries to the feet if they are allowed to drop.

- Wear standardized safety shoes during all work.

##### Eye protection

It is possible that battery acid can be discharged when working on defective batteries or when handling batteries improperly.

- Always wear eye protection when working on any defective or possibly defective batteries.

##### Safety gloves

It is possible that battery acid can be discharged when working on defective batteries or when handling batteries improperly.

- Always wear acid-proof safety gloves when working on any defective or possibly defective batteries.

#### General Safety Information and Information About Fitting / Removal



**DANGER!**

**Risk of Death, Serious Injury, or Damage**

Lighted cigarettes dropped onto an upholstered seating system can cause a fire resulting in death, serious injury, or damage. Mobility device occupants are at particular risk of death or serious injury from these fires and resulting fumes because they may not have the ability to move away from the mobility device.

- DO NOT smoke while using this mobility device.



**WARNING!**

**Risk of Serious Injury or Damage**

Storing or using the mobility device near open flame or combustible products can result in serious injury or damage.

- Avoid storing or using the mobility device near open flame or combustible products.



**CAUTION!**

**Risk of crushing**

Various components such as the drive unit, batteries, seat etc are very heavy. This results in injury hazards to your hands.

- Note the high weight of some components. This applies especially to the removal of drive units, batteries and the seat.



**CAUTION!**

**Injury hazard if the mobility device starts moving unintentionally during repair work**

- Switch the power supply off (ON/OFF key).
- Engage the drive.
- Before lifting up, secure the mobility device by using chocks to block the wheels.

**CAUTION!****Fire and burn hazard due to electrical short-circuit**

- The mobility device must be completely switched off before removal of voltage-carrying components! To do this, remove the batteries.
- Avoid short-circuiting the contacts when carrying out measurements on voltage-carrying components.

**CAUTION!****Risk of burns from hot surfaces on the motor**

- Allow the motors to cool down before commencing work on them.

**CAUTION!****Injury hazard and risk of damage to mobility device due to improper or incomplete maintenance work**

- Use only undamaged tools in good condition.
- Some moving parts are mounted in sockets with PTFE coating (Teflon™). Never grease these sockets!
- Never use "normal" nuts instead of self-locking nuts.
- Always use correctly-dimensioned washers and spacers.
- When reassembling, always replace any cable ties which were cut during dismantling.
- After completing your work / before renewed start-up of the mobility device, check all connections for tight fitting.
- After completing your work / before renewed start-up of the mobility device, check all parts for correct locking.
- Only operate the mobility device with the approved tyre pressures (see technical data).
- Check all electrical components for correct function. Note that incorrect polarity can result in damage to the control system.
- Always carry out a trial run at the end of your work.

**CAUTION!****Risk of injury and damage to property, if the maximum speed reduction on a wheelchair with a lifter does not function correctly**

The wheelchair's control unit must reduce the maximum possible speed as soon as the lifter is raised.

- Test the maximum speed reduction for correct function after any maintenance work or modifications to the wheelchair.

**CAUTION!****Any changes to the drive program can affect the driving characteristics and the tipping stability of the mobility device**

- Changes to the drive program may only be carried out by trained Invacare providers.
- Invacare supplies all mobility devices with a standard drive program ex-works. Invacare can only give a warranty for safe mobility device driving behavior - especially tipping stability - for this standard drive program.



Mark all current settings for the mobility device (seat, armrests, backrest etc.), and the associated cable connecting plugs, before dismantling. This makes reassembly easier. All plugs are fitted with mechanical locks which prevent release of the connecting plugs during operation. To release the connecting plugs the safety locks must be pressed in. When reassembling ensure that these safety locks are correctly engaged.

## 3 Hygiene

### 3.1 Handling of Returned Used Products

When reconditioning or repairing returned mobility devices:

- Take precautions for yourself and the product.
- Use protection equipment as specified locally.

#### Before Transport (According to Biological Agents Ordinance)

Treat product according to following process steps:

Process Step	Component	Application	Conditioning technique	Work Station
Manual cleaning	Surface of used device	Before repair or reconditioning	Use saturated towel to apply cleaning detergent and remove residues after impact.	Cleaning and disinfection
Disinfection	Surface of used device	Before repair or reconditioning	Use saturated disinfectant wipes and clean* the device surface.	Cleaning and disinfection

\*Invacare uses detergent "Nücosept special" 1.5% in water ml/ml

#### Disinfection Tools

- Disposable wipes (fleece)
- Brushes to clean areas difficult to access

#### Further Information

 For more information contact your Invacare service department.



## 4 Setup

### 4.1 General information on setup

The tasks described in this chapter are intended to be performed by trained and authorized service technicians for initial setup. They are not intended to be performed by the user.

### 4.2 Adjusting Seating Position

To adapt the mobility device optimally to the requirements of the user, we recommend that you ask your authorised Invacare provider to adjust the seat depth individually. Adapting the seat to the user's seating position depends on which seat has been fitted, and should be carried out in the following sequence:

1. Adjusting lower leg length and seat depth. See 4.3 *Adjusting Lower Leg Length*, page 9.
2. Adjusting centre of gravity of seat frame. See 4.5 *Adjusting Centre of Gravity of Seat*, page 10.
3. Checking that castors can move freely.
4. Checking that wheelchair is stable and will not tip over. See 4.5.6 *Check tipping stability*, page 15.
5. Repetition of steps 2 to 4, if necessary.



**CAUTION!**

**Risk of injury after tilting of mobility device caused by blocked castors**

- Always check seat depth settings for both forward and reverse movement. Make sure that castors can rotate freely and have not contact to any fixed mobility device component.



**CAUTION!**

**Risk of tipping over**

Any change in the seating position can negatively influence the stability of the power wheelchair.

- Always make sure that the wheelchair is stable and will not tip over, after adjusting the seating position.



**CAUTION!**

**Any changes to drive program can affect driving characteristics and tipping stability of vehicle.**

- Changes to drive program may only be carried out by trained Invacare providers.
- Invacare supplies all mobility devices with a standard drive program ex-works. Invacare can only give a warranty for safe vehicle driving behaviour - especially tipping stability - for this standard drive program.



**CAUTION!**

**Risk of Crushing to Hands and Feet**

The seat is very heavy. Risk of injury to hands and feet.

- Pay attention to hand and feet.
- Use proper lifting techniques.

### 4.3 Adjusting Lower Leg Length

Invacare offers a range of legrests which can be adjusted individually. See user manual.

### 4.4 Adjusting Seat Depth

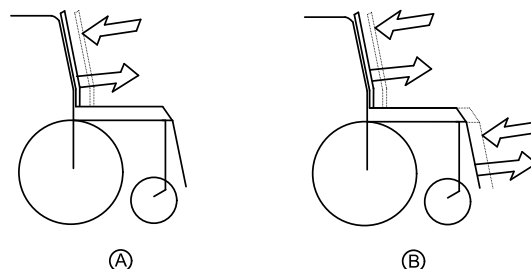

Fig. 4-1

Ⓐ: Seat depth

Ⓑ: Centre of gravity of the seat/seat position

Seat depth Ⓐ can be adjusted by moving backrest in relation to seat surface.

#### Seat Systems

For details on

- Firm seat

- Max seat

refer to revision 15 of this service manual.

### Modulite Seat

Seat depth can be adjusted by moving backrest in relation to seat surface. See user manual. For seat depth settings, see 4.5.5 Seat Depth Setting, page 13.

## 4.5 Adjusting Centre of Gravity of Seat

The centre of gravity of the seat can be adjusted by mounting the seat frame farther towards the front or the rear of the chassis.



### CAUTION!

The seating system of the mobility device is delivered ex works with a standard adjustment of centre of gravity (CoG), which meets 80 – 90 % of user requirements. CoG can be adjusted individually. However, any change in this adjustment setting can negatively influence the stability of the mobility device.

– You must perform an individual risk analysis every time you change the centre of gravity of the seating position to ensure the safety and stability of the mobility device.

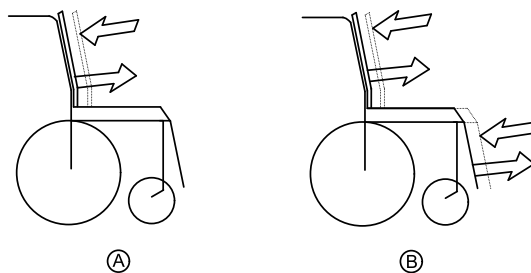

Fig. 4-2

Ⓐ: Seat depth

Ⓑ: Centre of gravity of the seat



The user weight and seat depth have strong influences on the choice of the centre of gravity (CoG). If the user is heavy and the seat depth is greater, the focus should be the farther back. For best possible driving characteristics of rear-wheel drive mobility device, the weight should be distributed: 30 – 40 % front and 60 – 70 % rear. Front- and centre-wheel drives are uncritical with regard to distribution of user weight.

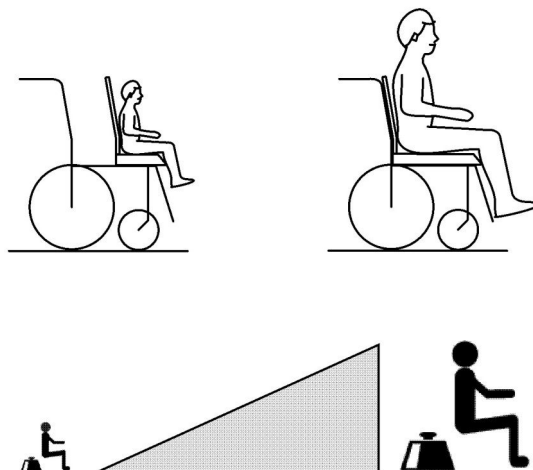

Fig. 4-3

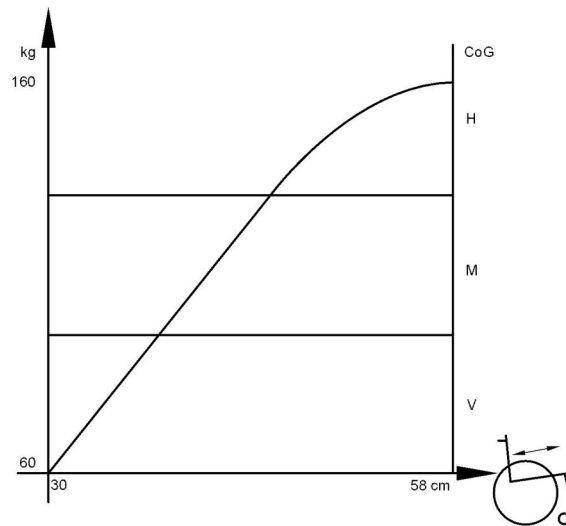

Fig. 4-4

**CAUTION!**

**Risk of damage due to collisions of the legrests with other parts of the mobility device.**

- Set legrests to smallest angle before adjusting seat centre of gravity.
- Pay attention with adjusting the seat centre of gravity that the legrests do not touch any other parts of the wheelchair. This ensures that the legrests cannot collide with other parts of the wheelchair.

**Seat Systems**

For details on

- Firm seat
- Max seat

refer to revision 15 of this service manual.

For details on Modulite seat, see below.

**4.5.1 Modulite Seat**

The Modulite seat is available in two versions:

- Adjustment of the centre of gravity via the lateral profiles of the telescopic seat frame (plate and strap). See 4.5.2 *Telescopic Seat Frame, page 12*.
- Adjustment of the centre of gravity via the oblong holes of the seat adaptor (one-piece seat plate). See 4.5.3 *One-Piece Seat Plate, page 12*.

If the mobility device is used with drive lock-out, the seat centre of gravity can be safely monitored in the corresponding seat position.

Drive lock-out is a feature designed to prevent the wheelchair from being driven after the seating system has been tilted beyond the safe total angle relative to the vertical position. The total angle can be any combination of tilt, recline and/or surface angle. See the user manual for more information on this function. The seat position settings with various combinations of seat depth, seat width, cushion type and backrest style are described in 4.5.5 *Seat Depth Setting, page 13*.

- Place a wooden block under the backrest to avoid collisions between frame and back.



If the mobility device is used with the drive lock-out, variations to the values stated below can occur. See 4.5.4 *Mounting Position of Seat Frame, page 13* and 4.5.5 *Seat Depth Setting, page 13*.

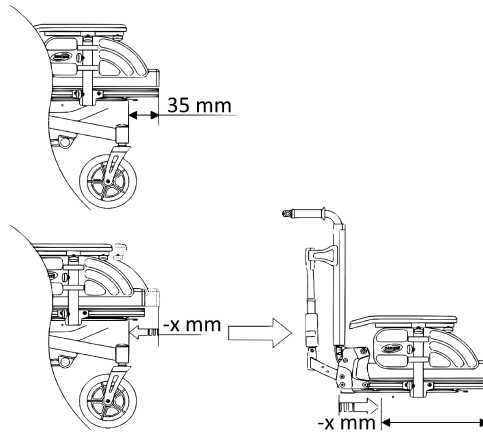

Fig. 4-5

The front edge of the seat frame profile should be located 35 mm in front of the steering heads of the castors. If you decrease this value, make sure that

- You decrease the seat depth by the same value and
- There are no collisions between the legrests and the castors.

#### 4.5.2 Telescopic Seat Frame



- 6 mm Allen key

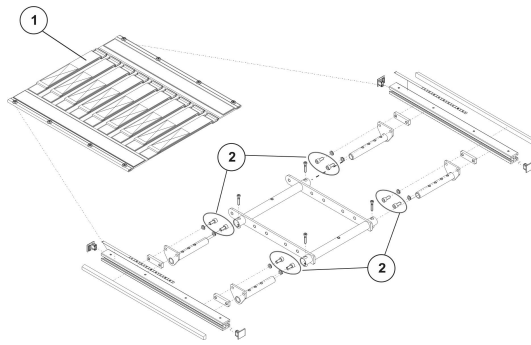

Fig. 4-6

1. Remove seat plate or sling seat (1). See Modulite service manual, “Adjusting seat width/backrest width” chapter.
2. Loosen screws (2) in front and rear, left and right – DO NOT remove.
3. Shift position of seat.
4. Re-tighten screws.
5. Install seat plate or sling seat.

#### 4.5.3 One-Piece Seat Plate



- 6 mm Allen key

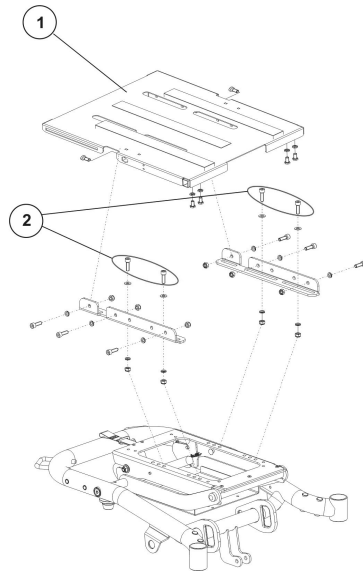

Fig. 4-7 This picture is an example.

1. Remove seat plate.
2. Loosen screws (2) left and right – DO NOT remove.
3. Shift position of seat frame.
4. Tighten screws.
5. Install seat plate.

#### 4.5.4 Mounting Position of Seat Frame

The centre of gravity of the seat can be adjusted by mounting the seat frame farther towards the front or the rear on the seat support. See Modulite service manual. If the mobility device is used with drive lock-out, choose different screw positions, for example:

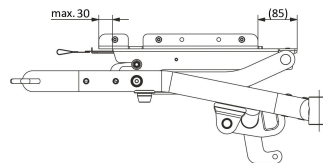

Fig. 4-8 Mounting Position of Seat Frame with Flex3 Backrest and Seat Depth 51 cm

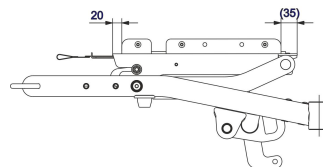

Fig. 4-9 Mounting Position of Seat Frame on Seat Support Without Drive Lock-Out

#### 4.5.5 Seat Depth Setting

Adjust the seat depth using the profile scale (1) in accordance with the following table:

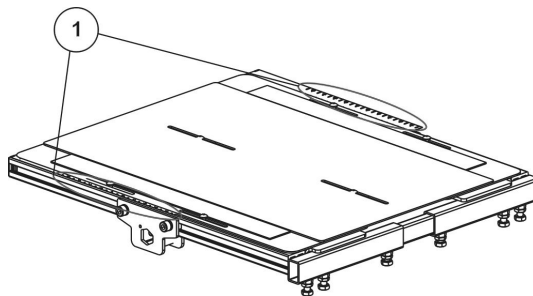

Fig. 4-10

<b>Flex3 Backrest / Seat Plates</b>			
Seat width 38 cm	Profile length	Seat depth	Setting value / profile scale
	51 cm	41 cm	4.5
	51 cm	46 cm	2
	54.5 cm	51 cm	1
Seat width 43 cm	Profile length	Seat depth	Setting value / profile scale
	51 cm	41 cm	5
	51 cm	46 cm	2.5
	54.5 cm	51 cm	1.5
Seat width 48 / 53 cm	Profile length	Seat depth	Setting value / profile scale
	51 cm	41 cm	5.5
	51 cm	46 cm	3
	54.5 cm	51 cm	2
<b>Flex3 Backrest / Sling Seat</b>			
Seat width 38 cm	Profile length	Seat depth	Setting value / profile scale
	51 cm	41 cm	3.5
	51 cm	46 cm	1
	54.5 cm	51 cm	0
Seat width 43 cm	Profile length	Seat depth	Setting value / profile scale
	51 cm	41 cm	4
	51 cm	46 cm	1.5
	54.5 cm	51 cm	0.5
Seat width 48 / 53 cm	Profile length	Seat depth	Setting value / profile scale
	51 cm	41 cm	4.5
	51 cm	46 cm	2
	54.5 cm	51 cm	1
<b>Tension-Adjustable Backrest / Seat Plates</b>			
Seat width 38 / 43 / 48 / 53 cm	Profile length	Seat depth	Setting value / profile scale
	51 cm	41 cm	7.5
	51 cm	46 cm	5
	51 cm	51 cm	2.5
<b>Tension-Adjustable Backrest / Sling Seat</b>			
Seat width 38 / 43 / 48 / 53 cm	Profile length	Seat depth	Setting value / profile scale
	51 cm	41 cm	6.5
	51 cm	46 cm	4
	51 cm	51 cm	1.5
<b>MatrX (PB) / Seat Plates</b>			
Seat width 38 / 43 cm	Profile length	Seat depth	Setting value / profile scale
	51 cm	41 cm	7
	51 cm	46 cm	5
	51 cm	51 cm	2.5

Seat width 48 cm	Profile length	Seat depth	Setting value / profile scale
	51 cm	41 cm	7.5
	51 cm	46 cm	5
	51 cm	51 cm	3
Seat width 53 cm	not offered		
<b>MatrX (PB) / Sling Seat</b>			
Seat width 38 / 43 cm	Profile length	Seat depth	Setting value / profile scale
	51 cm	41 cm	6
	51 cm	46 cm	4
	51 cm	51 cm	1
Seat width 48 cm (53 cm is not offered)	Profile length	Seat depth	Setting value / profile scale
	51 cm	41 cm	7
	51 cm	46 cm	4
	51 cm	51 cm	1.5
Seat width 53 cm	not offered		

#### 4.5.6 Check tipping stability

Any change in seating position can negatively influence tipping stability of the power wheelchair. For this reason, after adjusting the seating position, you should always verify tipping stability of mobility device.



#### CAUTION!

**Any changes to drive program can affect driving characteristics and tipping stability of mobility device.**

- Changes to drive program may only be carried out by trained Invacare® specialist dealers.
- Invacare® supplies all mobility devices with a standard drive program ex-works. Invacare® can only give a warranty for safe driving behaviour - especially tipping stability - for this standard drive program.

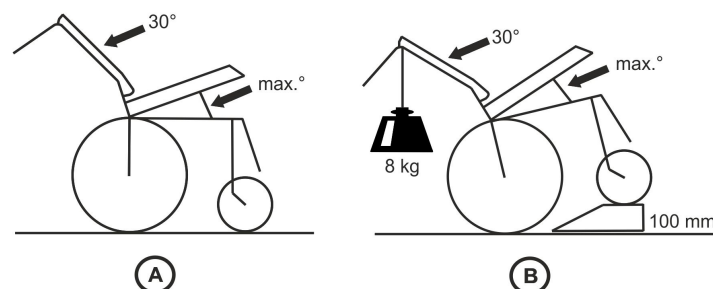

#### Tipping stability check



1. Set following angle on wheelchair:
  - Recline 30°
  - Seat tilt max.
2. Allow user to down in mobility device in a sitting position that is typical for them.
3. Drive front wheels of mobility device onto a step about 100 mm high. This can be done using a ramp, for example (illustration B).
4. Make sure that front wheels are pointed backwards compared to direction of travel.
5. Attach a reference weight of 8 kg to the push bar (illustration B).
6. Verify that mobility device is at most in a balanced or "floating" condition in this position. This means that front wheels can slightly lose contact with ground, but chair must not tip back onto its anti-tipper wheels. If mobility device does not fall back onto its anti-tipper wheels, tipping stability is OK. If mobility device falls back onto its anti-tipper wheels, you must either:
  - Shift center of gravity far enough forward that chair does not fall onto anti-tipper wheels or
  - Install adaptor
7. Repeat steps described above after each modification to verify tipping stability.

## 5 Testing

### 5.1 Testing Motor

-  • Phillips screwdriver, size 2
-  • Digital multimeter with resistance measurement

1. Remove shroud that covers power module. See 6.9 *Shrouds, page 48*.
2. Unplug cable of motor (A) from power module.
3. Connect multimeter (B) to motor plug contacts (C) and (D) and measure resistance between contacts.

 A resistance of between 0.5 ohms and 5 ohms indicates a motor ready for operation. A resistance of between 15 ohms and infinity indicates a defective motor. High resistances are normally caused by bad connections or worn carbon brushes.

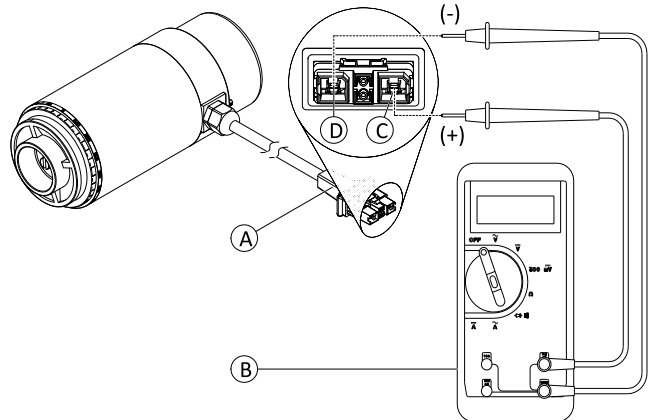



Fig. 5-1 DuraWatt motor serves as an example.

### 5.2 Testing Motor Brake

 This test should only be carried out on mobility device with conventional motor-gearbox units.





#### CAUTION!

**Risk of damage to power module due to shorts in motor brake**

- NEVER connect a shorted motor brake to an intact power module.
- Always replace shorted brakes immediately.

 A defective motor can damage the power module, but a defective power module cannot damage the motor.

-  • Phillips screwdriver, size 2
-  • Digital multimeter with resistance measurement

1. Remove shroud that covers power module. See 6.9 *Shrouds, page 48*.
2. Unplug cable of motor (A) from power module.
3. Connect multimeter (B) to motor plug contacts (E) and (F) and measure resistance between contacts.

 A resistance of between 40 ohms and 80 ohms indicates an intact brake. A resistance of 0 ohms or a very high resistance (mega-ohms or infinity) indicates a short-circuit, a bad connection or a defective brake.

4. If there is a defect, replace motor and send it to Invacare Service for inspection or repair.

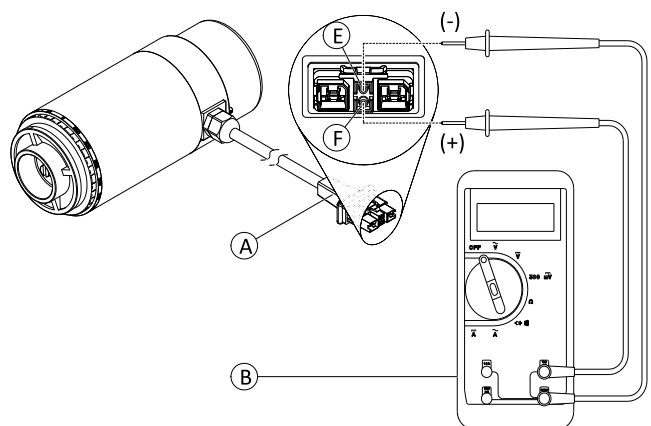

Fig. 5-2 DuraWatt motor serves as an example.

### 5.3 Rain test

- Check to ensure that the black battery terminal caps are secured in place, gaiter is not torn or cracked where water can enter and that all electrical connections are secure at all times.
- Do not use the mobility device if the gaiter is torn or cracked. If the gaiter becomes torn or cracked, replace immediately.



### 5.4 Field Load Test

Old batteries lose their ability to store and release power due to increased internal resistance. In this procedure, batteries are tested under load using a digital voltmeter to check battery charge level at the charger connector. The charger connector is located on the remote. When voltage at the output drops 1.0 volts under load (2.0 volts for a pair), replace the batteries.

 Read these instructions carefully and the manufacturer’s instructions on the digital voltmeter before proceeding.

-  • Voltmeter

 **WARNING!**  
 – When performing the following steps, ensure your feet are clear from casters and wall, otherwise injury may result.

1. Switch electronics OFF on remote.
2. Make sure battery is fully charged. An extremely discharged battery will exhibit the same symptoms as a bad battery.
3. Remove footboard/legrests from mobility device.
4. Connect voltmeter leads to charger connector **(A)** on mobility device. Most digital voltmeters **(B)** are not affected by polarity. However, analog meters (meters with swinging needles) can be and should be used carefully.

 A good meter reading should be 25.5 VDC to 26.0 VDC with the chair in neutral.

5. Switch electronics ON on remote.
6. Ensure that your feet are clear from casters and wall.
7. Run mobility device in neutral for at least 2 minutes.
8. Sit in mobility device and place your feet against a door jam, workbench or other stationary object.
9. Carefully give forward command, trying to drive the mobility device through the stationary object. The load should draw between 30 amps to 40 amps from the batteries for 0.3 seconds.

 Performing this step puts a heavy load on the batteries as they try to push through the stationary object. If the wheels spin, have two individuals (one on each arm) apply as much downward pressure as possible on the arms of the mobility device.

10. Read meter while motors are straining to determine voltage under load.

 If the voltage drops more than 2.0 volts from a pair of fully charged batteries during the 0.3 seconds, they should be replaced regardless of the unloaded voltages.

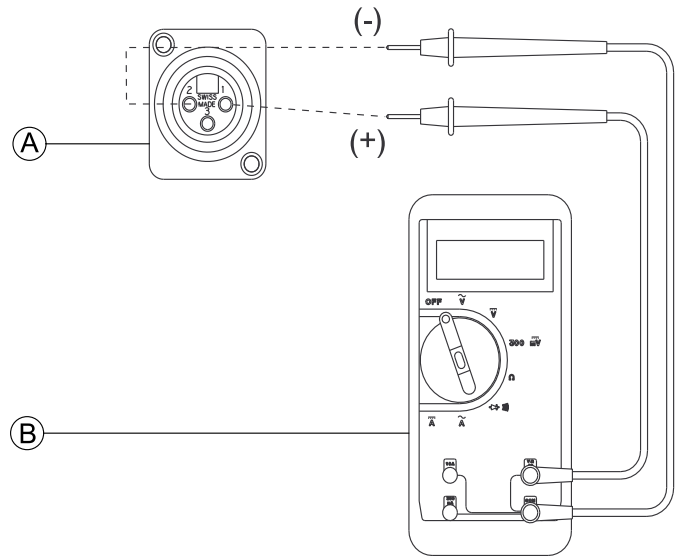

Fig. 5-3

### 5.5 Checking Battery Charge Level

The following “Dos” and “Don’ts” are provided for your convenience and safety.

DON'T	DO
Don't perform any installation or maintenance without first reading this manual.	Read and understand this manual and any service information that accompanies a battery and charger before operating the personal transporter.
Don't perform installation or maintenance of batteries in an area that could be damaged by battery spills.	Move the personal transporter to a work area before cleaning terminals, or opening battery box.
Don't make it a habit to discharge batteries to the lowest level.	Recharge as frequently as possible to maintain a high charge level and extend battery life.

DON'T	DO
Don't use chargers or batteries that are not appropriate for the chair.	Follow recommendations in this manual when selecting a battery or charger.
Don't put new batteries into service before charging.	Fully charge a new battery before using.
Don't tip or tilt batteries.	Use a carrying strap to remove, move or install a battery.
Don't tap on clamps and terminals with tools.	Push battery clamps on the terminals. Spread clamps wider if necessary.

## 5.6 Checking Actuator



- Digital multimeter with resistance measurement

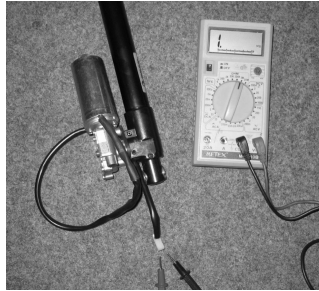

1. Turn OFF controls on remote.
2. If necessary, remove shroud.
3. Take note of the positions of all cables and sockets that they are connected to. Mark connectors and sockets or take a photograph with a digital camera.
4. Unplug actuator.
5. Connect multimeter to the contacts and measure the resistance between the contacts. The plug can have a different shape than shown in illustration.



A resistance below 1 ohms indicates a short-circuit. Very high resistances indicates (mega-ohms or infinity) indicates a defective actuator. Actuator must be replaced in both cases.

## 6 Service

### 6.1 General Warning Information on Installation Work



**CAUTION!**

**Risk of damage to vehicle**

Collisions can be caused if the adjusting washers are removed during fitting work to the drive wheels. Adjusting washers are often fitted between the drive shaft and the wheel hub to even out tolerances. If these adjusting washers are removed and not replaced again, collisions can be caused.

- Always replace the adjusting washers exactly as they were before you started dismantling.



**CAUTION!**

**Risk of injury and damage to property, if the maximum speed reduction on a mobility device with a lifter does not function correctly**

The mobility device's control unit must reduce the maximum possible speed as soon as the lifter is raised.

- Test the maximum speed reduction for correct function after any maintenance work or modifications to the mobility device.

### 6.2 Tightening Torques



**CAUTION!**

**Risk of damage to mobility device due to improperly tightened screws, nuts or plastic connections.**

- Always tighten screws, nuts etc. to the stated tightening torque.
- Only tighten screws or nuts which are not listed here fingertight.

The tightening torques stated in the following list are based on the thread diameter for the nuts and bolts for which no specific values have been determined. All values assume dry and de-greased threads.

Thread	Tightening Torque in Nm $\pm 10\%$
M4	3 Nm
M5	6 Nm
M6	10 Nm
M8	25 Nm
M10	49 Nm
M12	80 Nm
M14	120 Nm
M16	180 Nm

### 6.3 Troubleshooting

#### 6.3.1 Operational Faults

Proceed as follows if you have any problems:

1. First assess the possible cause of the problem using the following table.
2. Check the remote status display. Evaluate the flash error code.
3. Carry out the necessary checks and repairs as recommended in the following table.

The various power modules can be fitted in connection with different remotes in the mobility device. Rectification of operational faults depends on the power module fitted. The power modules used are described in the corresponding controls manual.



The tables for rectification of operational faults listed in the following chapters are only an excerpt from the original manufacturer's manuals. You can obtain the original manuals from Invacare.

### 6.3.2 Drive Fault Diagnosis

Problem	Other symptoms	Possible cause	Solution	Documentation
<b>Mobility device will not start</b>	The remote status display illuminates normally and shows an error code.	Drive motors disengaged	Engage drive motors	See corresponding remote manual
	Remote status display does not illuminate	Batteries defective	Replace batteries	See 6.11 Batteries, page 54
		Completely discharge battery	Pre-charge batteries	See user manual
		Power supply to remote interrupted	Check main fuse	See 6.11.6 Main Fuse, page 59
		Remote defective	Check cables between the modules for loose connections and damage	See 6.11.7 Checking Cables, page 62
Remote status display blinking	Various causes	Assess error code	See corresponding remote manual	
<b>Mobility device judders in drive mode</b>	None	Batteries defective (unstable voltage)	Replace batteries	See 6.11 Batteries, page 54
		Drive motor(s) defective	Replace motor(s)	See 6.7 Drive Components, page 27
			Replace carbon brushes	
<b>Batteries not being charged</b>	None	Batteries defective	Replace batteries	See 6.11 Batteries, page 54
	LEDs blinking on charging unit	Charging unit defective	Replace charging unit	See user manual
<b>Mobility device runs too slowly</b>	None	Remote defective	Replace remote	See corresponding electronics manual
		Batteries defective	Replace batteries	See 6.11 Batteries, page 54

### 6.4 Service Plan (Once a Year)

**CAUTION!**

**Risk of injury and damage to property, if the maximum speed reduction on a mobility device with a lifter does not function correctly**

The mobility device's control unit must reduce the maximum possible speed as soon as the lifter is raised.

- Test the maximum speed reduction for correct function after any maintenance work or modifications to the mobility device.

Component	Check	Remedy	Notes	✓
Armrests	Risk of damage to armrests	Replace shrouds, if damaged		
	Armrest fixings	Tighten screws		
Clothes-guard	Risk of damage to clothes-guards	Replace clothes-guards, if damaged		
	Clothes-guard fixings	Tighten screws		
Seat lock	Seat lock defective	Replace seat lock		
Tilt	Check SL retainer clip for correct fit	Replace SL retainer clip, if necessary		

Component	Check	Remedy	Notes	✓
Power recline (if fitted)	Risk of damage to backrest	Replace parts, if damaged		
	Seams	Tighten screws		
	Fixing	Replace actuator cable, if necessary		
	Check cable			
	Check function			
Frames (chassis) / battery mounting	Check fixings, welded seams and battery mounting	Tighten screws		
		Replace components, if necessary		
Wheel suspension and wheels	Check drive wheels for tight fit and side play	Adjust, replace wheel hubs	See <ul style="list-style-type: none"> <li>6.8.5 Replacing Drive Wheel (1-Bolt Installation), page 38</li> <li>6.8.6 Replacing drive wheel hub, page 40</li> </ul>	
	Check castors for tight fit, float and side play	Replace wheels, wheel fork or wheel bearings	See <ul style="list-style-type: none"> <li>6.8.7 Replacing Castor Wheel on Double-Sided Fork, page 40</li> <li>6.8.9 Replacing Steering Head Bearings on Castors, page 44</li> </ul>	
	Pneumatic tyres (if fitted)	Repair or replace, if damaged	See 6.8.8 Replacing Tyres, page 43	
Drive units, coupling mechanism	Check functions in drive and push modes	Replace motor, if necessary		
	Check coupling mechanism	Tighten screws/nuts, adjust or replace, if necessary		
Legrests	Check welded seams, interlocking, screws, foot-plates	Tighten, replace, if necessary		
Power elevating legrests (if fitted)	Check cable	Replace cable, if necessary		
	Check contacts			
	Check functions			
Lighting (if fitted)	Check cable	Replace bulb, LEDs or cable, if necessary		
	Check function			
Batteries	Check batteries for damage	Replace batteries, if necessary	See 6.11 Batteries, page 54	
	Check battery voltage	Charge batteries	See user manual	
	Check contacts and terminals	Clean contacts and terminals	See safety information in <ul style="list-style-type: none"> <li>6.11 Batteries, page 54 and</li> <li>6.11.5 Handling Damaged Batteries Correctly, page 59</li> </ul>	
Battery box	Check locking system, it must engage completely	Replace, if necessary		

Component	Check	Remedy	Notes	✓
Remote	Remote, status display flashing	Evaluate error/flash code		
	Fixings	Check fixings for tight fit, replace, if necessary		
	Cables and connecting plugs	Check connecting plugs for tight fit, replace, if necessary		
	Joystick function	Replace joystick, if necessary		
		Replace remote, if necessary		
Power supply	Check connecting plugs for tight fit, replace, if necessary			
Drive program	Check drive program version	Update software, if newer version available	See LiNX manual or revision 15 of this service manual	
Screws	Check screws for tight fit	Tighten screws, if necessary		

## 6.5 Overview Components

### 6.5.1 Mobility Device With Detachable Seat

#### Underneath Seat

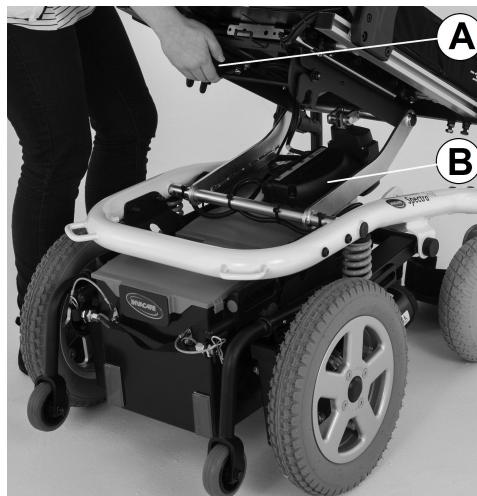

- Ⓐ Seat disengager
- Ⓑ Power module / Lighting PCB (optional) / Actuator module (optional)

**Tilt**

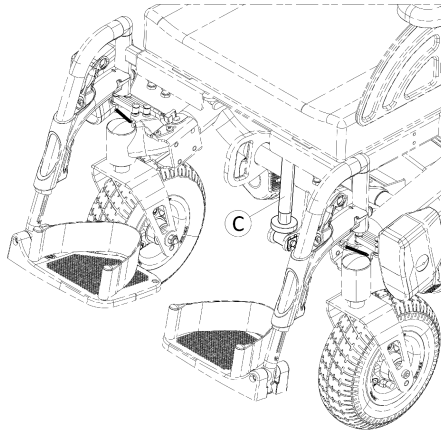

© Tilt tube / Tilt spindle / Tilt actuator

**G-Trac Sensor (Optional)**

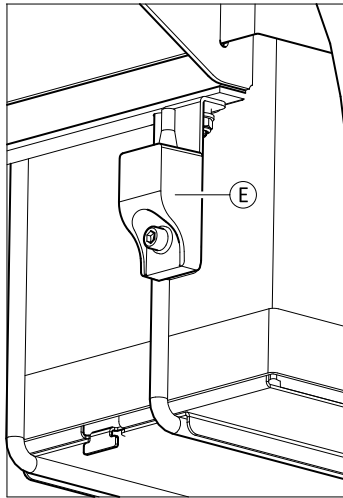

Ⓔ G-Trac sensor

The G-Trac sensor is located in the front, next to the battery connector.

**Operation Hour Counter (Optional)**

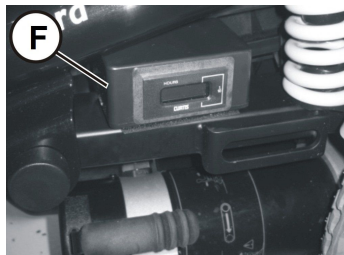

Ⓕ Operation hour counter

The operation hour counter is mounted laterally on the frame.

**6.5.2 Mobility Device With Lifter And Tilt Module**

**Electronic Modules**

The modules are located in the front, next to the battery connector.

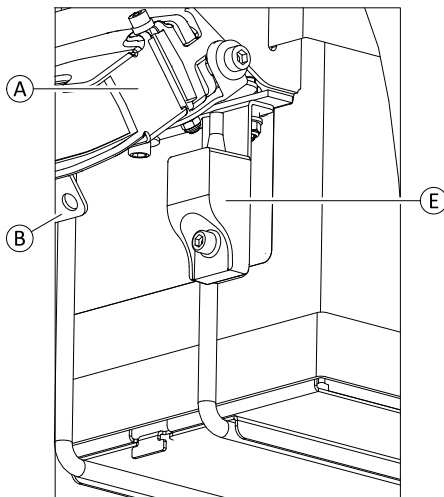

- Ⓐ Power module
- Ⓑ Lighting PCB (optional)
- Ⓔ G-Trac sensor (optional)

For older power modules see corresponding controls manual or earlier revision of this manual.

**Powered Tilt**

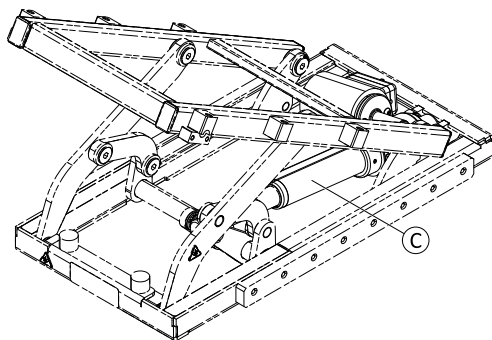

- Ⓒ Tilt actuator

**Lifter**

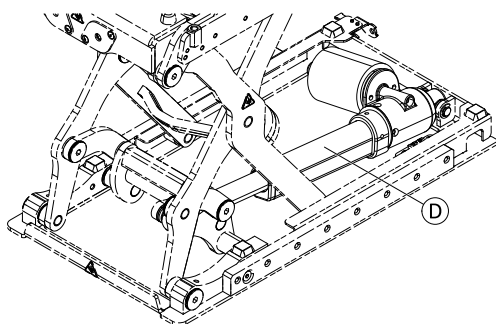

- Ⓓ Lifter actuator

**Operation Hour Counter (Optional)**

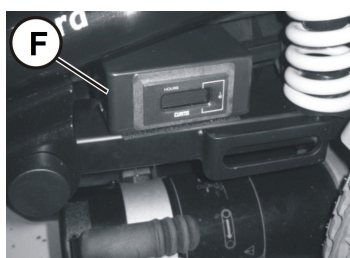

- Ⓕ Operation hour counter



The optional operation hour counter is mounted laterally on the frame.

## 6.6 Chassis

### 6.6.1 Replacing Kerb Climber (L-Shape Lever)



#### CAUTION!

#### Risk of crushing

Injury hazard to hands. The gas spring is under pressure.

- Be careful with your hands.
- Use suitable tools.



- 3 mm Allen key
- 6 mm Allen key
- 8 mm wrench
- 17 mm wrench
- Pliers
- Oblong wooden block (approx. 14 x 14 x 30 cm)



When removing, take care of small parts such as screws and washers. Put all small parts down so that they can be installed in correct sequence.

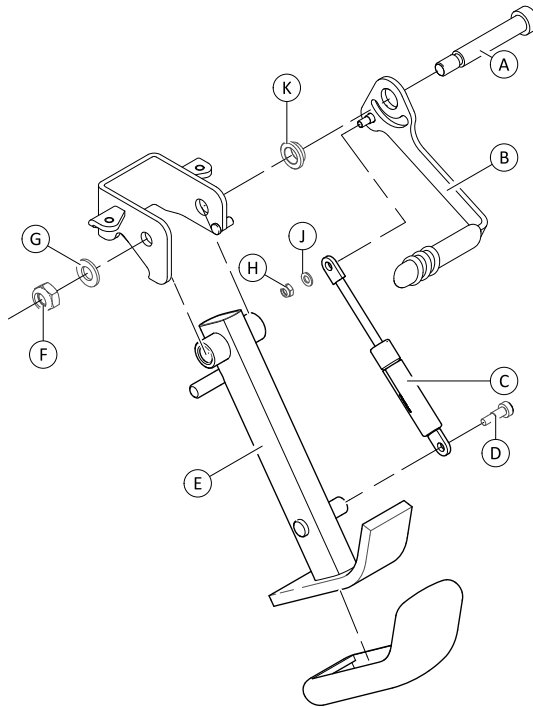

#### Removing Kerb Climber

1. Secure mobility device against rolling away.
2. If necessary, remove parts that are in the way like legrests or swinging axle.
3. Loosen and remove screw ①.
4. Pull gas spring ③ out of holder.
5. Loosen and remove nut ⑥ including washer ⑦.
6. Pull bolt ④ out of holder.
7. Remove switch lever ② including bushing ⑫, gas spring ③, washer ⑩ and nut ⑧.
8. If needed, loosen and remove nut ⑧ including washer ⑩ and replace gas spring ③.

#### Installing Kerb Climber



When applying the correct tightening torque to nut ⑥, ensure that kerb climber can move freely.

1. Install parts in reverse order.
2. Test all functions.

## 6.6.2 Replacing Kerb Climber (T-Shape Lever)



### CAUTION!

#### Risk of crushing

- Injury hazard to hands. The gas spring is under pressure.
- Be careful with your hands.
  - Use suitable tools.



- 4 mm Allen key
- 10 mm wrench
- 13 mm wrench
- 17 mm wrench
- Flat screwdriver
- Oblong wooden block (at least 14 x 14 x 30 cm)

1. Remove legrests.
2. Place wooden block under kerb climber.

### Removing Gas Spring

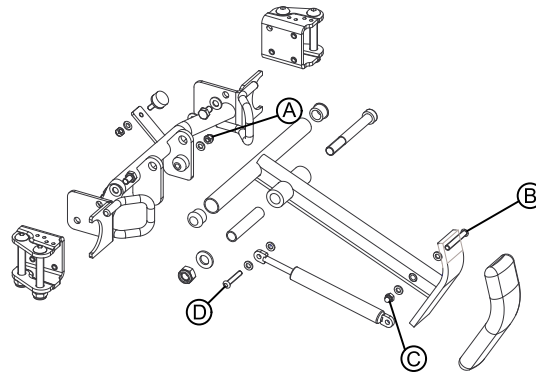

Fig. 6-1

1. Remove plastic cap (if fitted).
2. Loosen and remove bolt ④ and nut ①.
3. Loosen and remove bolt ② and nut ③.
4. Replace gas spring.

### Removing Kerb Climber

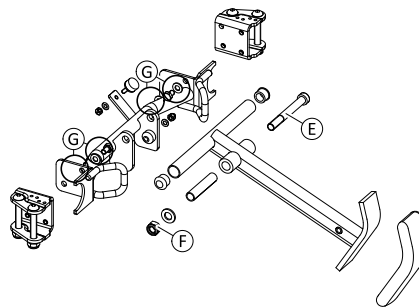

Fig. 6-2

1. Remove gas spring.
2. Loosen and remove bolt ⑤ and nut ⑥.
3. Replace kerb climber.

### Replacing Kerb Climber Assembly

1. Remove all four screws ⑦.
2. Replace kerb climber assembly.

### Installing Components

1. Install parts in reverse order.
2. Test all functions.

## 6.7 Drive Components

### 6.7.1 Preparing Replacement of Drive Components



**CAUTION!**

**Risk of Crushing to Hands and Feet by Weight of Mobility Device**

- Pay attention to hand and feet.
- Use proper lifting techniques.



**CAUTION!**

**Risk of Uncontrolled Movement of Mobility Device**

- Turn off power supply (ON/OFF key).
- Engage drive.
- Before raising mobility device, secure wheels by blocking them with wedges.
- Prevent the mobility device tipping by propping it up on a wooden block which is long and wide enough under the battery case. If the wooden block is too short or too high, the mobility device can still tip.



**CAUTION!**

**Fire and burns hazard if battery terminal is bypassed**

- Take great care to ensure that the battery terminals are never short-circuited with tools or mechanical mobility device parts.
- Ensure that the battery terminal caps have been replaced if you are not working on the battery terminals.



- Small flat screwdriver
- TX40 wrench
- 5 mm Allen key
- Oblong wooden block (at least 12 x 12 x 30 cm)
- Hairdryer
- Thread locking adhesive (Loctite 270 or similar)
- Oblique pliers
- Tie wraps



When removing, take care of small parts such as screws and washers. Put all small parts down so that they can be installed in correct sequence.

1. Remove legrests.
- 2.

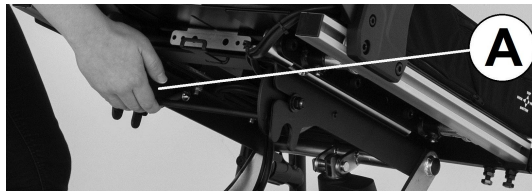

Fig. 6-3

Release seat **A** and tilt forwards.

3. Disconnect remote bus cable from power module or ACT.
4. Lift seat out of front anchorage and remove it.
5. Remove both battery boxes. See *6.11.1 Removing Battery Boxes, page 55*.  
If mobility device has no battery boxes, remove batteries from battery tray. See *6.11.3 Removing Batteries from Battery Tray, page 57*.
6. Disconnect motor plug from power module.
7. Motor cable is secured inside frames with tie wraps. Remove tie wraps with oblique pliers.
8. Place wooden block underneath mobility device and prop up mobility device.
9. Remove wheel. See *6.8.5 Replacing Drive Wheel (1-Bolt Installation), page 38*.

### 6.7.2 Overview Motor/Gearbox Unit

Not all motor-gearbox combinations are available for all models. Contact your provider or check the spare parts catalogue.

The following mounting instructions are valid for all combinations.

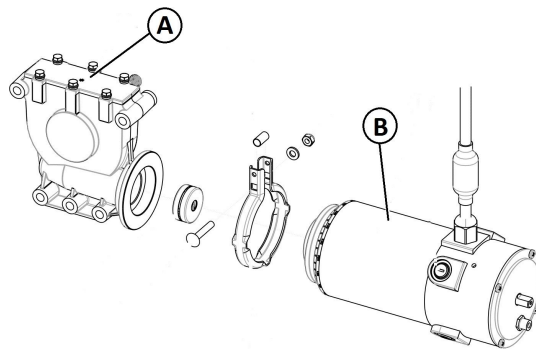

Fig. 6-4 Example of a motor/gearbox unit with SSD motor

**i** For description of old motors and components, see earlier revision of service manual.

### 6.7.3 Replacing Swing Arm



**CAUTION!**  
**Risk of Crushing to Hands and Feet by Weight of Mobility Device**

- Pay attention to hand and feet.
- Use proper lifting techniques.



**CAUTION!**  
**Risk of Uncontrolled Movement of Mobility Device**

- Turn off power supply (ON/OFF key).
- Engage drive.
- Before raising mobility device, secure wheels by blocking them with wedges.
- Prevent the mobility device tipping by propping it up on a wooden block which is long and wide enough under the battery case. If the wooden block is too short or too high, the mobility device can still tip.



**CAUTION!**  
**Risk of crushing**

- The motor-gearbox unit is very heavy. Risk of injury to hands.
- Pay attention to the heavy weight.



- 10 mm wrench
- 24 mm wrench
- 10 mm Allen key
- Pliers
- Oblong wooden block (at least 14 x 14 x 30 cm)

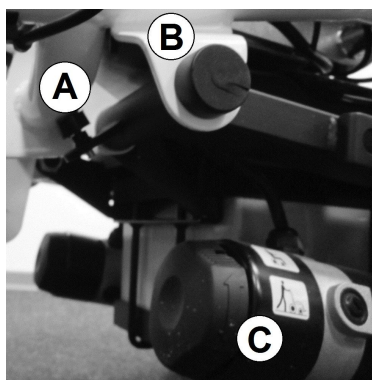

Overview of swing arm joint: rubber bumper (A), swing (B), and motor-gearbox unit (C).

Fig. 6-5

#### Removing Swing Arm From Chassis

1. Turn off electronics on remote.
2. Pull motor plug out of power module.
3. Open cable clamps and expose motor cable.

4.

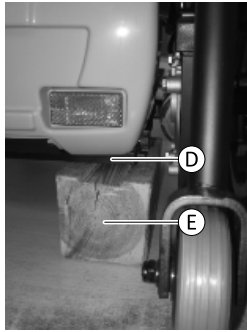

Fig. 6-6

Place wooden block underneath chassis.

5. Remove drive wheel. See 6.8.5 *Replacing Drive Wheel (1-Bolt Installation)*, page 38.  
6.

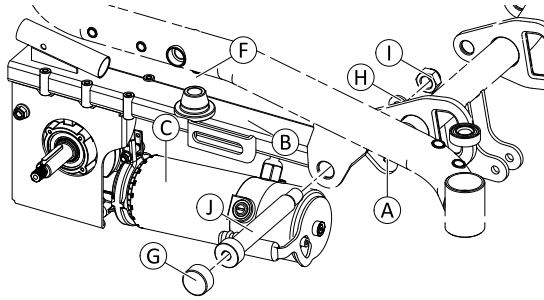

Fig. 6-7

Loosen counter nut and remove it together with rubber bumper (A).

7.



Compress spring (F) in downwards direction and remove spring.

8. Remove plastic cap (G). Pay attention to the powder coating.  
9. Loosen and remove nut (H) and washer (I) on inner side.  
10. Secure swing arm. Remove bolt (J) and swing arm.  
11. If required, replace other components such as the motor-gearbox unit. See corresponding topics.

#### Installing Swing Arm To Chassis

1. Install parts in reverse order.
2. Test all functions.

#### 6.7.4 Replacing Motor-Gearbox Unit



##### CAUTION!

##### Risk of Crushing to Hands and Feet by Weight of Mobility Device

- Pay attention to hand and feet.
- Use proper lifting techniques.



##### CAUTION!

##### Risk of Uncontrolled Movement of Mobility Device

- Turn off power supply (ON/OFF key).
- Engage drive.
- Before raising mobility device, secure wheels by blocking them with wedges.
- Prevent the mobility device tipping by propping it up on a wooden block which is long and wide enough under the battery case. If the wooden block is too short or too high, the mobility device can still tip.



##### CAUTION!

##### Risk of crushing

- The motor-gearbox unit is very heavy. Risk of injury to hands.
- Pay attention to the heavy weight.



- 5 mm Allen key
- 10 mm socket wrench
- 13 mm wrench (2x)
- Torque wrench 0 – 10 Nm (or similar)
- Torque wrench 5 – 30 Nm (or similar)
- Torque wrench 10 – 80 Nm (or similar)
- Two oblong wooden blocks, at least 14 x 14 x 30 cm

### Preparing Unit Replacement

This chapter refers to models with removable battery boxes.

For models with fixed battery trays it is required to remove the whole swing arm. See 6.7.3 *Replacing Swing Arm*, page 28.

1. Turn off electronics on the remote.
2. Remove the rear battery boxes. See 6.11.1 *Removing Battery Boxes*, page 55.
3. Pull motor plug out of power module.
4. Open the cable clamps and expose motor cable.
5. Remove drive wheel. See *Replacing Drive Wheel (5-Screw Installation)*.
6. Remove wheel hub. See 6.8.6 *Replacing drive wheel hub*, page 40.

### Removing Motor-Gearbox Unit

1. Remove fender. See 6.9.2 *Replacing fender*, page 49.
- 2.

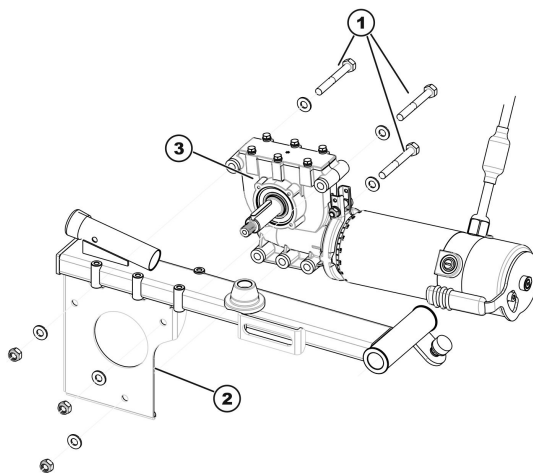

Fig. 6-8

Loosen and remove bolts (1) together with washers.

3. Pull motor-gearbox unit (3) rearward out of holder (2). Take into account heavy weight of components.

### Installing Motor-Gearbox Unit

1. Replace defective components.
- 2.

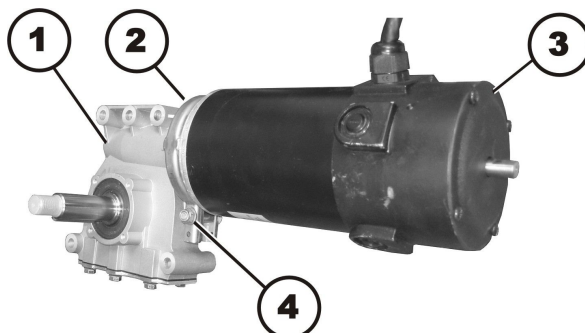

Fig. 6-9

Before installing new motor-gearbox unit, make sure sealing ring (2) is correctly mounted. The sealing ring securely attaches motor (3) and gearbox (1). The ring must be installed such that the self-locking nut (4) is located on the outside.

3. If sealing ring is incorrectly installed, rotate it around as described in 6.7.5 *Replacing or Rotating Motor-Gearbox Unit Sealing Ring*, page 31.
4. Install motor-gearbox unit in reverse order.

5.

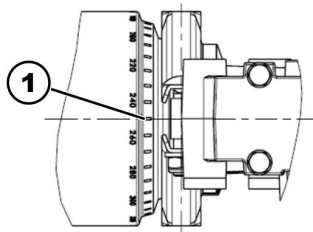

Fig. 6-10

Use scale to align motor to centre axis (1):

- 2-pole motors:
    - Left: 200°
    - Right: 280°
  - 4-pole motors:
    - Left: 280°
    - Right: 280°
6. Make sure that motor cable cannot be pinched or bent, and that it is not exposed to chafing in any place. The coupling lever must be able to move to the positions "Driving" as well as "Pushing".
  7. Tighten self-locking nut (4) of sealing ring to a torque of 4 Nm.
  8. Connect motor cable plug.
  9. Install parts in reverse order.
  10. If LiNX system is used, perform calibration process. See *Suggested programming procedure* in LiNX service manual.
  11. Test all functions.

### 6.7.5 Replacing or Rotating Motor-Gearbox Unit Sealing Ring



#### CAUTION!

#### Risk of crushing

The motor-gearbox unit is very heavy. Risk of injury to hands.  
– Pay attention to the heavy weight.



- 10 mm socket wrench

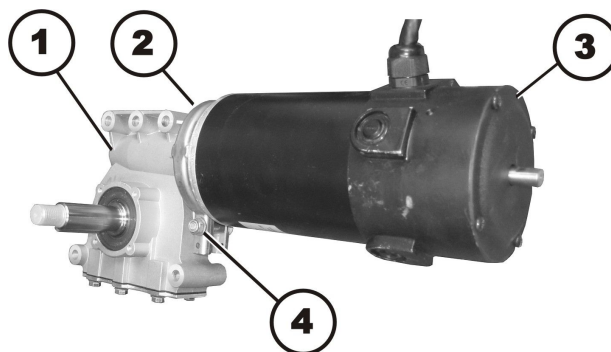

Fig. 6-11

#### Removing Sealing Ring

1. Remove motor-gearbox unit. See 6.7.4 *Replacing Motor-Gearbox Unit*, page 29.
2. Loosen and remove self-securing nuts (4) including washers.
3. Remove carriage bolt, which secures sealing ring (2).
4. Carefully bend sealing ring apart and remove it.

#### Installing Sealing Ring

1. Install sealing ring so that square hole for carriage bolt is on inside of mobility device.
2. Insert carriage bolt through sealing ring.
3. Install washer and self-locking nut.
4. Do not tighten self-locking nut completely, as the motor orientation must be adjusted during installation.

## 6.7.6 Replacing Motor-Gearbox Coupling



### CAUTION!

#### Risk of crushing

The motor-gearbox unit is very heavy. Risk of injury to hands.  
– Pay attention to the heavy weight.



- 10 mm socket wrench

### Removing Motor-Gearbox Coupling

1. Remove motor-gearbox unit. See 6.7.4 *Replacing Motor-Gearbox Unit*, page 29.
- 2.

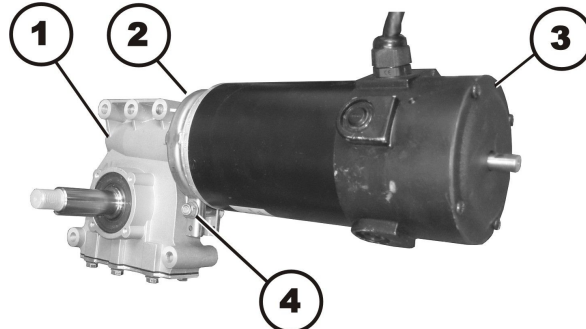

Fig. 6-12

- Loosen and remove self-securing nut (4).
3. Remove carriage bolt, which secures sealing ring (2).
4. Carefully bend sealing ring apart and remove it.



### WARNING!

#### Risk of damage to mobility device if coupling is not serviced correctly

– Be careful not to damage coupling mechanism during maintenance work.

5. Carefully pull motor (3) and gearbox (1) apart.
6. Remove component parts of coupling.
7. If necessary replace coupling.

### Installing Motor-Gearbox Coupling

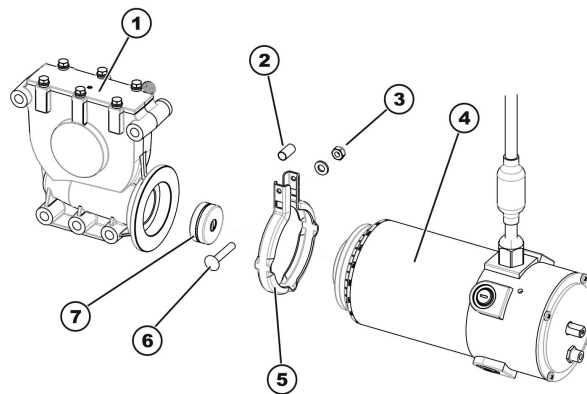

Fig. 6-13

1. Place new clutch (7) on motor axle. Pay attention to position of groove.
2. Position locking ring (5) on motor (4) or gearbox (1).
3. Carefully insert motor into gearbox. Pay attention to position of groove in axle of gearbox. If necessary, rotate motor and gearbox to correct position.
4. Insert carriage bolt through locking ring. Do not forget spacer sleeve (2).
5. Install washer and self-locking nut.
6. Do not tighten self-locking nut completely, as motor orientation must be adjusted during installation.
7. Install motor-gearbox unit. See 6.7.4 *Replacing Motor-Gearbox Unit*, page 29.

## 6.7.7 Replacing Carbon Brushes



The mobility device can be fitted with 2-pole or 4-pole motors. Always replace all carbon brushes on both motors at the same time. Use only the same type of carbon brushes.



 DuraWatt motors are service-free due to lifetime brushes.



**CAUTION!**  
**Risk of Crushing to Hands and Feet by Weight of Mobility Device**  
 – Pay attention to hand and feet.  
 – Use proper lifting techniques.



- 6 mm Allen key
- 10 mm socket wrench
- Flat screwdriver
- Two oblong wooden blocks, at least 14 x 14 x 30 cm

### Removing Carbon Brushes

1. Turn off mobility device.
2. Remove drive wheels. See *Replacing Drive Wheel (5–Screw Installation)*.
- 3.

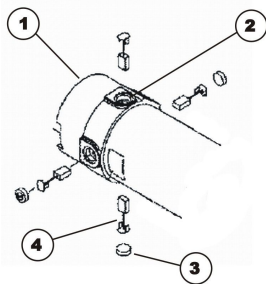

Fig. 6-14

Set engaging lever to “Push” to disengage motor (1).



You can loosen bolt (5) with 10 mm socket wrench and then turn motor around so that you can access rear carbon brushes more easily.

4. Loosen and remove all four plastic caps (3) using a flat screwdriver.
5. Note fixing position and location of carbon brushes.



Used carbon brushes need to be refitted exactly in the same position from which they were taken to guarantee optimum contact to the collector.

6. Make a marking on motor and carbon brushes to guarantee correct refitting.
7. Remove carbon brushes completely from mounting (2).
8. Check carbon brush and spring for level of wear, broken components or discolouration.

### Installing Carbon Brushes

1. Depending on condition of brush and spring:
  - either replace brushes in exactly the same position from which they were taken or
  - fit new brushes.
2. Refit plastic caps and tighten them firmly.
3. Turn motor round in position so that engaging lever can be set both to "Push" and "Drive" position.
4. Retighten bolt (5) finger-tight.
5. Refit drive wheels. See *Replacing Drive Wheel (5–Screw Installation)*.
- 6.



The following procedure is necessary to run the carbon brushes in after replacement and thus guarantee maximum performance.



**CAUTION!**  
**Risk of accidents**  
 Hazards to workers, surroundings and mobility device  
 – Do not leave mobility device unattended during following procedure.  
 – Make sure that both drive wheels are raised and cannot touch ground.  
 – Secure area.

Lift mobility device up on one side and get a second person to place a wooden block at least 14 cm high underneath it so that drive wheel is suspended freely.

7. Repeat this on the other side of mobility device.
8. Allow motors to run for an hour in forward direction.
9. Allow motors to cool down for 30 minutes.

10. Allow motors to run for an hour in reverse direction.
11. Lift mobility device off wooden blocks.

### 6.7.8 Replacing Engaging Turn Knob

 When replacing the engaging turn knob, you must ensure that the correct fitting position is used during assembly.

- 
-  • 3 mm Allen key
- 

1.

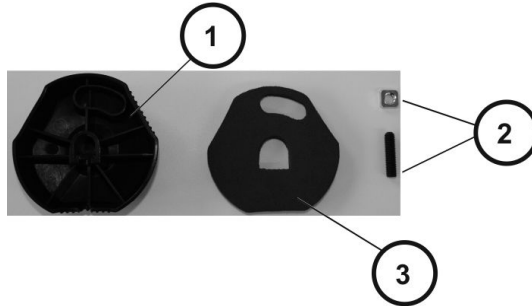

Fig. 6-16

Screw shim onto grub screw.

2. Place screw joint in engaging turn knob (rear side (1)).
- 3.

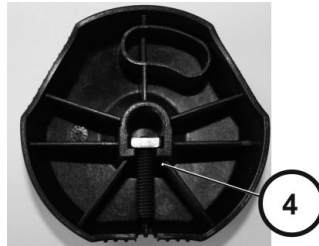

Fig. 6-17

Check that screw joint (4) is positioned precisely in engaging turn knob.

4. Place nonwoven fabric (3) in engaging turn knob (rear side (1)).
- 5.

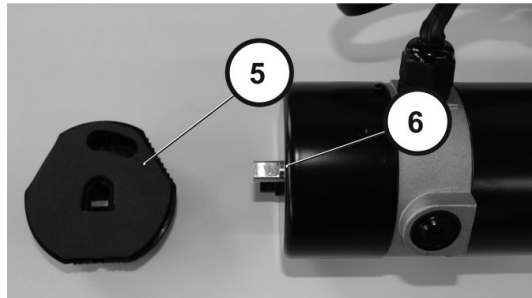

Fig. 6-18

When installing engaging turn knob (5) make sure that position (6) is correct.

6.

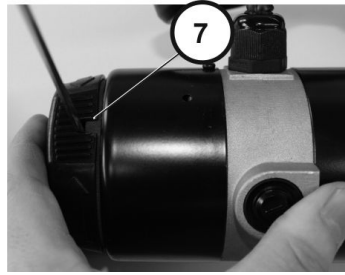

Fig. 6-19

Tighten bolt (7).

7.

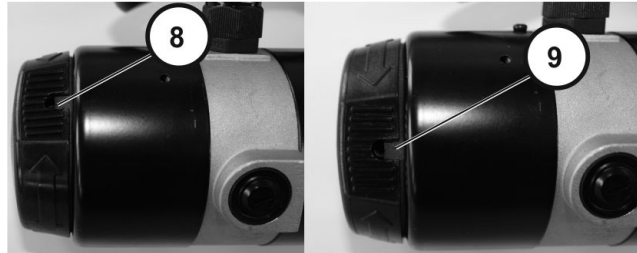

Fig. 6-20

Check that engaging turn knob can be turned to "push" position (clockwise) and "drive" position (counterclockwise).

## 6.8 Wheels

### 6.8.1 Tyre Pressure



**CAUTION!**  
**Risk of damage to rim and tyre when tyre pressure is exceeded**  
 – Observe recommended tyre pressure.

For recommended tyre pressure see inscription on tyre, rim, or contact Invacare. Compare table below for conversion.

psi	bar
22	1.5
23	1.6
25	1.7
26	1.8
28	1.9
29	2.0
30	2.1
32	2.2
33	2.3
35	2.4
36	2.5
38	2.6
39	2.7
41	2.8
42	2.9
44	3.0

### 6.8.2 Tyre Types

There are three different types of tyres or inner tubes, and specific points must be observed for the replacement of each type. The individual types of tyres can be easily distinguished:

- Pneumatic tyres have black valve caps.

- Puncture-protected tyres have red valve caps.
- Puncture-proof tyres have no valves.









There are five chapters about tyre repair and wheel replacement:









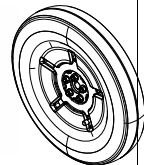

- *Replacing Drive Wheel (5-Screw Installation)*
- *6.8.5 Replacing Drive Wheel (1-Bolt Installation), page 38*
- *6.8.7 Replacing Castor Wheel on Double-Sided Fork, page 40*
- *Replacing Castor Wheels on Single-Sided Fork*
- *6.8.8 Replacing Tyres, page 43* deals with tube repair and replacing solid tyres.

 Not all chapters are necessarily contained in this manual.

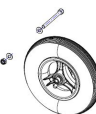
 Specific tightening torques for wheels and rim halves are listed in *6.8.3 Specific Tightening Torques, page 36*.

### 6.8.3 Specific Tightening Torques







	Drive Wheels								
	10" x 3"	12 1/2" x 2 1/4"			14"				
									
<b>Wheel Fixation</b>	70 Nm	70 Nm	33 Nm	35 Nm	70 Nm	33 Nm	60 Nm	25 Nm	18 Nm
<b>Rim Halves</b>	25 Nm	25 Nm	10 Nm	25 Nm	25 Nm	10 Nm	25 Nm	25 Nm	18 Nm

	Castor Wheels									
	6"	8"				9"			10"	
										
<b>Wheel Fixation</b>	18 Nm	18 Nm	25 Nm	16 Nm	16 Nm	25 Nm	25 Nm	25 Nm	18 Nm	100 Nm
<b>Rim Halves</b>	10 Nm	25 Nm	5 Nm	—	—	—	25 Nm	5 Nm	25 Nm	25 Nm

### 6.8.4 Overview of Power Wheelchair Models and Wheel Types

- Not all wheel types are available for all power wheelchairs, see footnotes.
- The symbols indicate three tyre types:

		
pneumatic = black valve cap	puncture-protected = red valve cap	puncture-proof = no valve

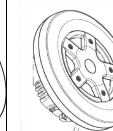
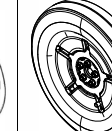
Models	Drive wheels								
	10" x 3"	12 1/2" x 2 1/4"			14"				
									
4-Spoke Rim (1-Bolt Installation)	3-Spoke Rim (1-Bolt Installation)	5-Spoke Rim (1-Bolt Installation)	5-Spoke Plastic Rim (1-Bolt Installation)	3-Spoke Rim (1-Bolt Installation)	5-Spoke Rim (1-Bolt Installation)*	5-Spoke Rim (5-Screw Installation)	5-Spoke Rim for True Track*	Solid Rim (5-screw installation)	
TDX SP2							<input type="checkbox"/> <input checked="" type="checkbox"/> <input checked="" type="checkbox"/>		
Storm <sup>4</sup> Series							<input type="checkbox"/> <input checked="" type="checkbox"/> <input checked="" type="checkbox"/>	<input type="checkbox"/> <input checked="" type="checkbox"/> <input checked="" type="checkbox"/>	
Kite					<input type="checkbox"/> <input checked="" type="checkbox"/> <input checked="" type="checkbox"/>		<input type="checkbox"/> <input checked="" type="checkbox"/> <input checked="" type="checkbox"/>		
Bora		<input type="checkbox"/> <input checked="" type="checkbox"/>	<input type="checkbox"/> <input checked="" type="checkbox"/>						
Fox		<input type="checkbox"/> <input checked="" type="checkbox"/>		<input checked="" type="checkbox"/>					
Stream						<input type="checkbox"/> <input checked="" type="checkbox"/>			
Mirage			<input type="checkbox"/> <input checked="" type="checkbox"/>	<input type="checkbox"/>					
Dragon			<input type="checkbox"/> <input checked="" type="checkbox"/>	<input type="checkbox"/>					
Pronto M41	<input checked="" type="checkbox"/>								
AVIVA RX									<input type="checkbox"/> <input checked="" type="checkbox"/> <input checked="" type="checkbox"/>

\* For wheelchair-specific mounting instruction, see respective manual.

Models	Castor Wheels									
	6"		8"				9"		10"	
	Single-Sided/ Double-Sided Fork	Double-Sided Fork					Single-Sided/ Double-Sided Fork	Double-Sided Fork	Single-Sided Fork	Single-Sided Fork
TDX SP2	■									
Storm <sup>4</sup> Series									□ ■ ■	□ ■ ■
Kite							* * □ ■		□ ■ ■	□ ■ ■
Bora		■		□ ■	■		□ ■			
Fox		■	■							
Stream							■			
Mirage		■	□ ■		■					
Dragon							■			
Pronto M41	■									
AVIV-A RX						■		□ ■ ■		

\* For wheelchair-specific mounting instruction, see respective manual.

### 6.8.5 Replacing Drive Wheel (1-Bolt Installation)

This chapter deals with drive wheels that are installed with one central bolt.



**CAUTION!**  
**Risk of Crushing to Hands and Feet by Weight of Mobility Device**  
 – Pay attention to hand and feet.  
 – Use proper lifting techniques.



**CAUTION!**  
**Risk of Uncontrolled Movement of Mobility Device**  
 – Turn off power supply (ON/OFF key).  
 – Engage drive.  
 – Before raising mobility device, secure wheels by blocking them with wedges.  
 – Prevent the mobility device tipping by propping it up on a wooden block which is long and wide enough under the battery case. If the wooden block is too short or too high, the mobility device can still tip.



- 19 mm wrench
- Flat screwdriver
- Tightening kit
- Oblong wooden blocks (at least 14 x 14 x 30 cm)

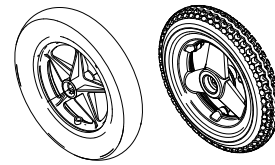

### Removing Wheel

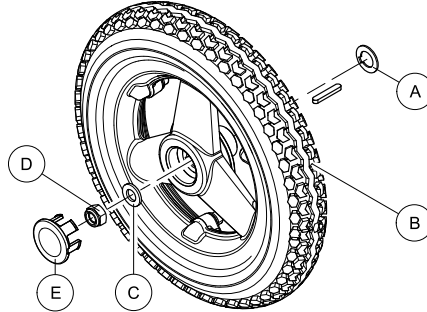

Fig. 6-21

1. Remove plastic cap **E**.
2. Loosen and remove nut **D** and washer **C**.
3. Remove wheel **B** from axle.
4. Remove remaining washer **A**.

### Installing Wheel

1. Install parts in reverse order.
2. When installing wheel, pay attention to correct direction of rotation.
3. Tighten nut to prescribed torque. See 6.8.3 *Specific Tightening Torques*, page 36.

### Replacing Wheel (10" x 3")



- 19 mm wrench
- Oblong wooden blocks (at least 14 x 14 x 30 cm)

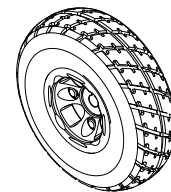

### Removing Wheel

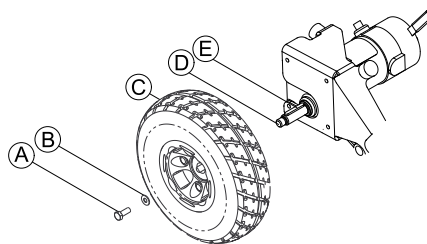

Fig. 6-22

1. Loosen and remove nut **A** and washer **B**.
2. Remove wheel **C** from drive shaft **D**. If necessary, use wheel puller to remove wheel from drive shaft.

### Installing Wheel

1. Apply anti-seize compound to drive shaft **D** and keystick **E**.



**Do not apply more than one-inch (25.4 mm) (in length) thin film of anti-seize compound to the drive shaft. Applying more than one-inch (25.4 mm) (in length) can cause the anti-seize compound to leak resulting in damage to flooring (carpet, tile, etc.).**

2. When installing wheel, pay attention to correct direction of rotation.
3. Align keystick in drive shaft with cutout in wheel hub and position wheel on drive shaft.



Ensure keystick in cutout on drive shaft. Keystick must line up with wheel hub cutout.

4. Tighten nut to prescribed torque. See 6.8.3 *Specific Tightening Torques*, page 36.

### 6.8.6 Replacing drive wheel hub



**CAUTION!**

**Risk of material damage**

Collisions can be caused if the adjusting washers are removed during fitting work to the drive wheels.

- Adjusting washers are often fitted between the drive shaft and the wheel hub to even out tolerances. If these adjusting washers are removed and not replaced again, collisions can be caused.
- Always replace the adjusting washers exactly as they were before you started dismantling.



- Torque wrench with 19 mm socket spanner
- Blade screwdriver
- Mounting kit

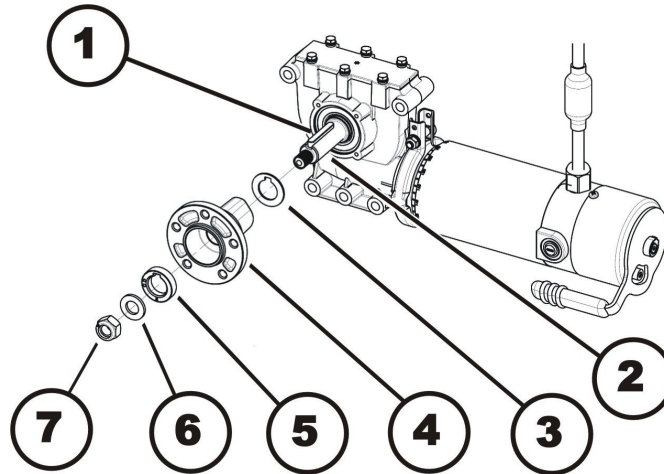

#### Removing drive wheel hub

1. Remove hub cover with screwdriver.
2. Use 19 mm socket wrench to loosen and remove nuts (7).
3. Remove washer (6).
4. Remove distance ring (5).
5. Pull wheel hub (4) off of axle (2).
6. Remove shim ring (3).
7. Remove feather key (1) from axle.

#### Installing drive wheel hub



**CAUTION!**

**Risk of injury if the wheels come off**

If drive wheels are insufficiently attached during assembly, they can come off during driving.

- Tighten nuts to 70 Nm when mounting drive wheel hubs.
- Always use new nuts with undamaged clamping parts.

1. Install parts in reverse order.
2. Use a thin film of lubricant to replace the wheel hub on axle.

### 6.8.7 Replacing Castor Wheel on Double-Sided Fork



- 5 mm Allen key
- 13 mm wrench
- Oblong wooden block (at least 14 x 14 x 30 cm)



- 13 mm wrench (2x)
- Oblong wooden block (at least 14 x 14 x 30 cm)







- 6 mm Allen key
- 13 mm wrench
- Oblong wooden block (at least 14 x 14 x 30 cm)

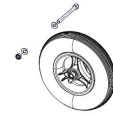

- 6 mm Allen key
- 13 mm wrench
- Oblong wooden block (at least 14 x 14 x 30 cm)

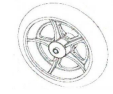

- 5 mm Allen key
- Oblong wooden block (at least 14 x 14 x 30 cm)



- 5 mm Allen key
- 13 mm wrench
- Oblong wooden block (at least 14 x 14 x 30 cm)

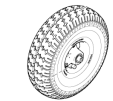

### Removing Wheel

1. Place wooden block underneath mobility device and prop up mobility device.
2. Remove end-caps from bolt and nut (if applicable).
- 3.

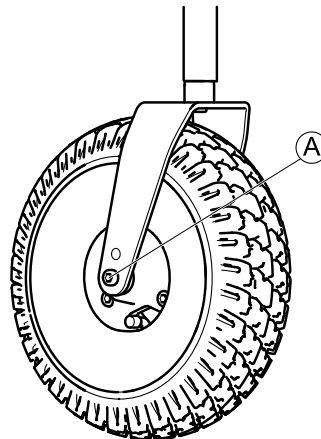

Fig. 6-23

Remove nut from bolt (A).

4. Remove bolt and wheel from fork.

### Installing Wheel

1. Install parts in reverse order.
2. When installing wheel, pay attention to correct direction of rotation.
3. Tighten nut to prescribed torque. See 6.8.3 *Specific Tightening Torques*, page 36.

### Replacing Castor Wheel (Aviva RX and Storm<sup>4</sup> Max)



- 5 mm Allen key (up to August 2016)
- TX40 Torx key (starting August 2016)
- Oblong wooden block (at least 14 x 14 x 30 cm)

## Removing Wheel

1. Loosen and remove bolts (A).
- 2.

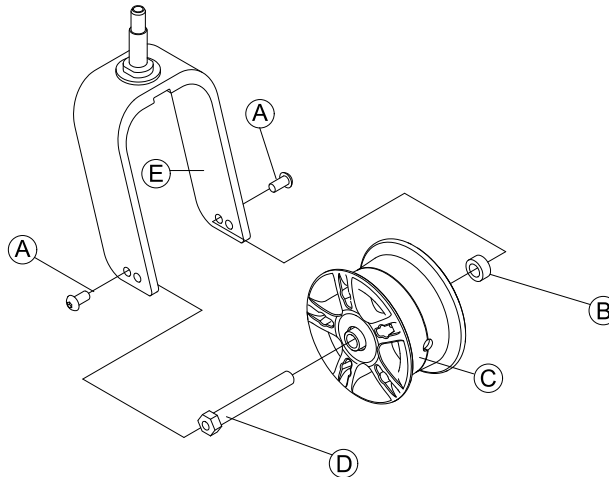

Fig. 6-24

Pull wheel (C) including axle (D) and bushing (B) out of fork (E).

## Installing Wheel



### CAUTION!

#### Risk of injury from wheels coming loose

If wheels are insufficiently secured during mounting, it can come loose when driving.

- When mounting wheels tighten bolts with prescribed torque.
- Secure all bolts using a suitable blocker.
- Never use normal nuts instead of self-locking nuts.
- Always use new nuts and bolts with an undamaged coating.

1. Install parts in reverse order. Pay attention to correct direction of rotation when installing wheels.
2. Test all functions.

## Replacing Castor Wheel (6 inch wheel)



- 2 x 7/16 inch wrench
- Oblong wooden block (at least 14 x 14 x 30 cm)



## Removing Wheel

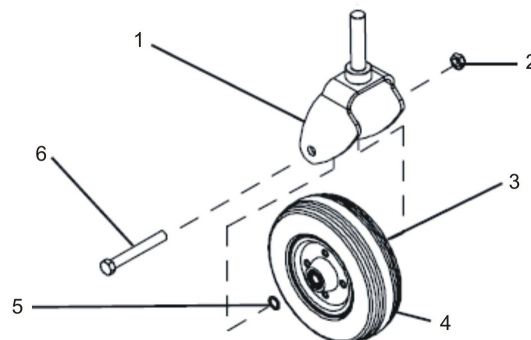

Fig. 6-25

1. Loosen nut (2).
2. Remove screw (6).
3. Remove two washers (3) and (5).
4. Remove wheel (4).
5. Replace any defective parts.

## Installing Wheel

1. Install parts in reverse order.
2. When installing wheel, pay attention to correct direction of rotation.
3. Tighten nut to prescribed torque. See 6.8.3 *Specific Tightening Torques*, page 36.

## 6.8.8 Replacing Tyres

### Repairing Pneumatic and Puncture-Protected Tyres



- 6 mm Allen key
- Tightening kit
- Oblong wooden block (at least 12 x 12 x 30 cm) for propping up mobility device
- Repair kit for tyre repair or a new inner tube
- Talcum powder
- Tyre pump or compressor



#### **WARNING!**

##### **Risk of Injury**

If tyre with one or more damaged rim threads is inflated, rim could burst and cause serious injury.

- Do not inflate tyre if one or more rim threads are damaged.
- Immediately replace rim with damaged threads.



#### **WARNING!**

##### **Risk of Explosion**

There is considerable pressure in the tyre. Risk of injury. Parts can be thrown out and injure you if you do not secure rim halves.

- Secure rim halves with joiner's clamps.



##### **Risk of Damage to Rim Threads**

Incorrectly tightened screws can cause damage to rim threads.

- Tighten rim screws with prescribed tightening torque.

1. Remove wheel as described in respective chapter in this manual.



#### **CAUTION!**

##### **Risk of Damage by Gel When Repairing Puncture-Protected Tyres With Red Valve Caps**

Valve can become blocked by the puncture protection gel and get unusable.

- During following work you should always hold up valve so that puncture protection gel cannot enter valve.

2. Remove valve cap.
3. Let air escape completely out of tyre by firmly pressing in pin in the centre of valve.



#### **CAUTION!**

##### **Risk of Explosion**

The wheel explodes if air pressure has not been released from wheel before wheel rim is removed.

- Always let all air out of tyre before removing rim.

- 4.

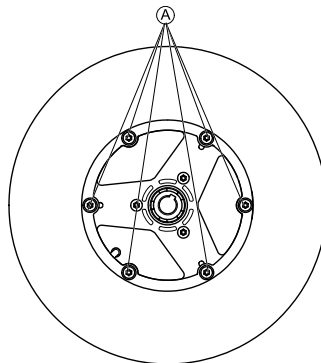

Fig. 6-26 This picture is an example.

Remove screws **A** on inside of wheel.

5. Remove rim halves from wheel.
6. Remove inner tube from tyre.
7. Repair inner tube and re-fit it, or replace it with a new one.



If old inner tube has been repaired and is to be used again, and became wet during repair, it is easier to replace it if it is lightly dusted with talcum powder beforehand.

8. Install tyre in reverse order.
9. Apply rim halves to wheel.
10. Inflate tyre a little.
11. Place screws in wheel rim and tighten screws with prescribed torque. Make sure that inner tube is not clamped between wheel rim halves.

12. Make sure that tyre is contacting wheel rim directly.
13. Inflate tyre to prescribed pressure.
14. Make sure that tyre is still closely contacting wheel rim.
15. Screw valve cap on.
16. Install wheels according to instruction. See respective chapter.

### Repairing Solid Tyre

-  • 6 mm Allen key
- 3 joiner's clamps with plastic caps

- !** **Risk of Damage to Rim Threads**
- Incorrectly tightened screws can cause damage to rim threads.
  - Tighten rim screws with prescribed tightening torque.

1. Remove wheel as described in respective chapter in this manual.
2. Secure rim halves against unexpected discharge with three joiner's clamps. When doing so, make sure that you do not scratch rims.
- 3.

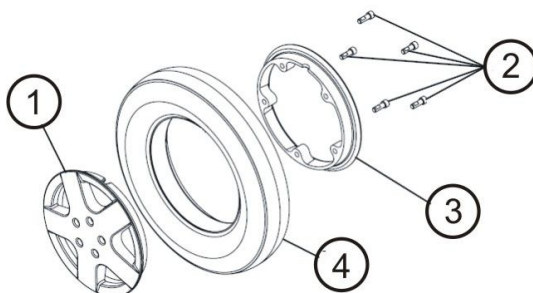

Fig. 6-27

- Loosen and remove screws (2) on inside of wheel.
4. Loosen joiner's clamps carefully and alternately until you can remove rim halves without risk.
5. Remove inner (3) and outer (1) half of rim from tyre (4).
6. Replace any defective or worn parts.
7. Install tyre in reverse order.
8. When fitting rim halves together, make sure that drill holes and threads for screws are placed exactly on top of each other.
9. Place joiner's clamps in position.
10. Tighten joiner's clamps alternately in small stages until rim halves are precisely aligned.
11. Install and tighten screws.
12. Remove joiner's clamps.
13. Install wheel as described in respective chapter in this manual.

### 6.8.9 Replacing Steering Head Bearings on Castors



- CAUTION!**  
**Risk of Crushing to Hands and Feet by Weight of Mobility Device**
- Pay attention to hand and feet.
  - Use proper lifting techniques.



- CAUTION!**  
**Risk of Uncontrolled Movement of Mobility Device**
- Turn off power supply (ON/OFF key).
  - Engage drive.
  - Before raising mobility device, secure wheels by blocking them with wedges.
  - Prevent the mobility device tipping by propping it up on a wooden block which is long and wide enough under the battery case. If the wooden block is too short or too high, the mobility device can still tip.



- CAUTION!**  
**Incorrect reassembly can damage bearings and cause castors to come off.**
- The single-row angular ball bearing rings are not identical on both sides. There is only one correct way to insert them.
- Follow assembly instructions precisely.



- 19 mm socket wrench
- Torque wrench
- Flat large screwdriver
- Oblong wooden block (at least 12 x 12 x 30 cm) for propping up mobility device
- Parallel Pin Punches (6/8)
- Hammer (300 g - 500 g)
- Shaft retaining compound (e.g. Loctite 662)

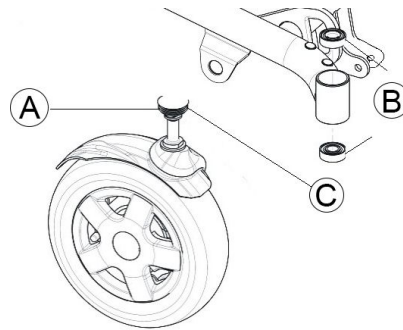

Fig. 6-28

The figure above shows an overview of the individual parts.

(A)	Plastic cap
(B)	Ball bearings
(C)	Nut



When removing, take care of small parts such as screws and washers. Put all small parts down so that they can be installed in correct sequence.

### Removing Steering Head Bearings

1. Place wooden block under mobility device on the side on which ball bearing is to be replaced.
2. The wheel on the side where bearing is to be replaced must have enough ground clearance to pull it out of bearing.
3. Secure mobility device against rolling away.
- 4.

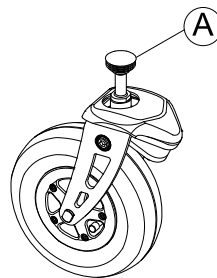

Fig. 6-29

Carefully remove plastic cap (A) with large screwdriver.

5.

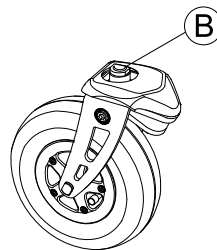

Fig. 6-30

Loosen and remove nut (B). Hold wheel so that it does not rotate when removing nut.

6. Pull steering head shaft downwards out of steering head tube.
7. Take washers out of tube.
8. Take ball bearing out of tube.  
If needed, use hammer and parallel pin punch to drive bearing out of housing. Hit outer ring of bearing.

### Installing Steering Head Bearings



Make sure you glue-in bearings every time you change them, even though they were not glued-in in the first place.



**CAUTION!**

**Incorrect reassembly can damage bearings and cause castors to come off**

Single-row angular ball bearing rings are not identical on both sides. There is only one correct way to insert them.

- Bearings must always be installed so that narrow borders of the ball bearings are facing each other (inside).
- Steering head bolts and nuts must always be pressing against wide (outside) border of ball bearings. Otherwise, bearings will be pressed apart and damaged by bolts.



Fig. 6-31

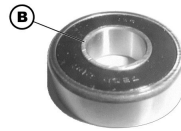

Fig. 6-32

The illustrations show the wide border of the ball bearing on the outside of the ball race (A) and the narrow ball bearing edge on the inside (B).

1. Clean and degrease inner surface of housing and outer diameter of new bearing.
- 2.



**Shaft retaining compound can cause damage to varnish and bearing parts**

- Apply only a small trace of shaft retaining compound.
- Make sure shaft retaining compound does not touch varnished parts or sealing ring.

Apply shaft retaining compound to outer ring of ball bearing.

3. Make sure you insert ball bearings exactly as described above. Thicker inner bearing ring must face outwards.
4. Move bearing 2–3 times to distribute the glue between bearing and housing.
5. Apply shaft retaining compound to second bearing. Check that thicker inner bearing ring faces outwards.
6. Install bearing on fork, pay heed to the warnings above.
7. Make sure that washers are correctly replaced.
8. Insert fork into frame. After installation, castor should rotate freely but bearings should have no play.
9. Tighten nut with 16 Nm.
10. Loosen nut, and tighten again with torque wrench.
11. Install plastic cap.

**6.8.10 Replacing manual wheel lock**



Tools:

- 4 mm Allen key

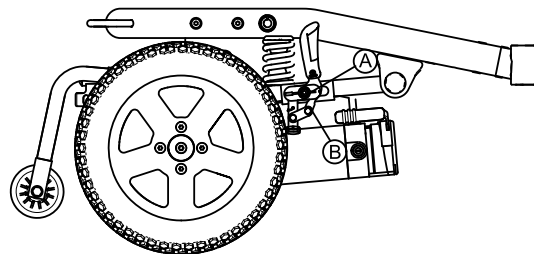

1. Loosen Allen screw (A).
2. Take off brake (B).
3. Take off panel sheet (not visible in image).
4. Replace parts in reverse order.
5. Test function.

### 6.8.11 Replacing anti-tipping mechanism with screw



**CAUTION!**

**Risk of tipping over if the anti-tipping mechanism is installed incorrectly.**

– Always install the anti-tipping mechanism in the first drill hole (long adjustment) on a mobility device with a lifter.



- 10 mm socket wrenches (two of them)

1. Loosen and remove self-securing nut (3).
2. Remove screw.
3. Pull anti-tipping mechanism (1) rearward out of support tube (2).
4. Insert anti-tipping mechanism into support tube.

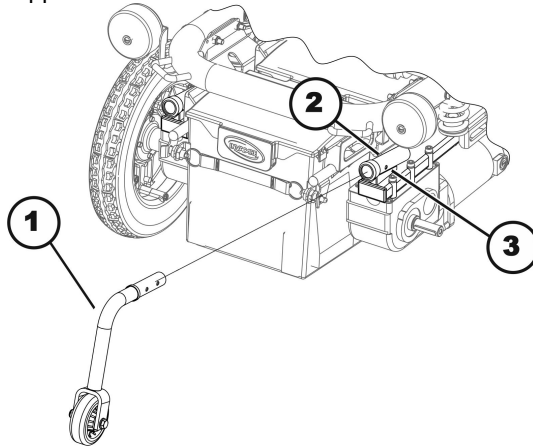

Fig. 6-33

- Mobility device with lifter
  - first drill hole (long setting)
- Mobility device without lifter
  - second drill hole (short setting)

5. Insert screw.
6. Re-position the self-securing nut and tighten.

### 6.8.12 Replacing anti-tipping mechanism with locking spring



**CAUTION!**

**Risk of tipping over if the anti-tipping mechanism is installed using a locking spring on a chair with a lifter.**

– Always install the anti-tipping mechanism using a screw in the first drill hole (long setting) on a chair with a lifter, as described in chapter 6.8.11 *Replacing anti-tipping mechanism with screw*, page 47.



Tools:

- Phillips screwdriver

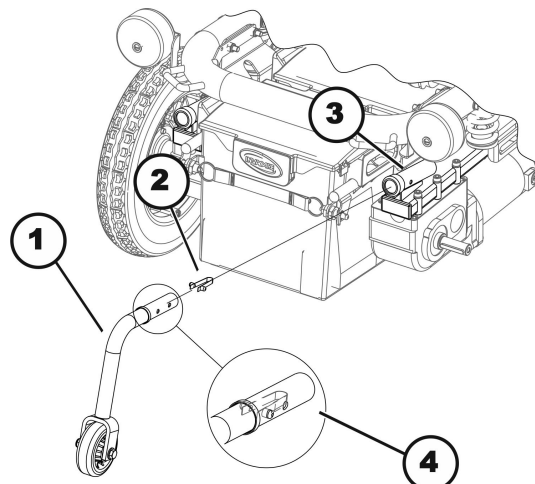

1. Press locking spring (2) together.
2. Only bolts in the support tube (3) are visible.

3. Pull anti-tipping mechanism out (1).
4. Check locking spring.
5. Replace locking spring if it is broken or has insufficient tension.
6. Replace anti-tipping mechanism.
7. Insert (possibly new) locking spring (4) into anti-tipping mechanism up to the second hole.
8. Insert anti-tipping mechanism into support tube. To do this, press locking spring together slightly.
9. Make sure that locking spring latches into holes provided for this purpose in the support tube.
10. Insert anti-tipping mechanism into support tube as far as it will go.

### 6.8.13 Replacing defective locking spring



**CAUTION!**

**Risk of tipping over due to defective locking springs.**

Defective locking springs can lead to loss or failure of the anti-tipping mechanism.  
 – Check carefully that the locking springs are intact.



Tools:

- A rod or Phillips screwdriver

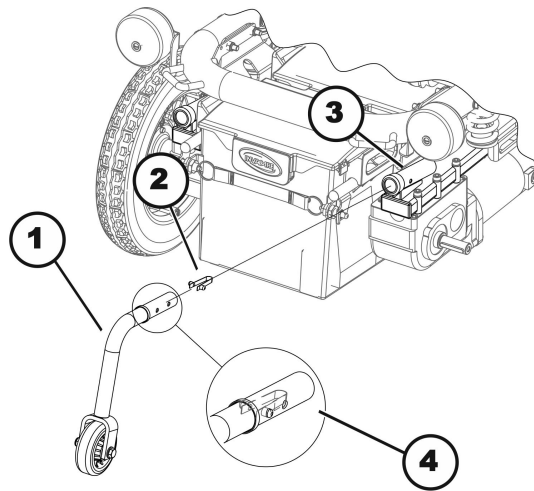

1. If necessary press defective locking spring together.
2. Pull anti-tipping mechanism (1) rearward out of support tube (3).
3. Remove defective locking spring. If it is not possible to remove the defective locking spring, push the defective locking spring (2) into the support tube using the rod or Phillips screwdriver.
4. Insert a new locking spring (4) into anti-tipping mechanism up to second hole.
5. Insert anti-tipping mechanism into support tube again as far as it will go. To do this, press locking spring together slightly.
6. Make sure that locking spring latches into the holes provided for this purpose in the support tube.

## 6.9 Shrouds

### 6.9.1 Replacing Front Shroud



- 4 mm Allen key

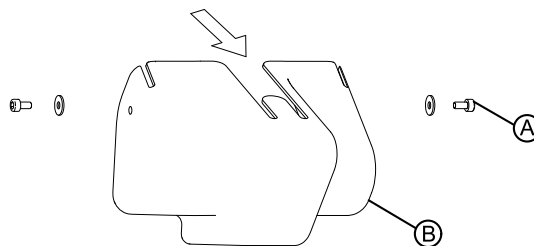

Fig. 6-34

1. Loosen and remove screws (A) and corresponding washers on front shroud (B).
2. Pull away front shroud.
3. Install parts in reverse order.



## 6.9.2 Replacing fender



### CAUTION!

**Risk of crushing to hands and feet by the weight of the mobility device**

- Pay attention to hand and feet.
- Use proper lifting techniques.



### CAUTION!

**Risk of injury caused by uncontrolled movement of the mobility device**

- Switch power supply off (ON/OFF key)
- Engage drive.
- Before raising mobility device, secure the wheels by blocking them with wedges.
- Prevent mobility device from tipping by propping it up with a wooden block which is long and wide enough under the battery case. If the wooden block is too short or too high, the mobility device can still tip.



Tools:

- 5 mm Allen key
- Mounting kit
- Wooden block (approx. 12 x 12 x 30 cm) for propping up mobility device



If the fender is replaced, the existing motor bracket screws are reused. Make sure that screws are inserted in the correct position.

1. Remove legrests.
- 2.

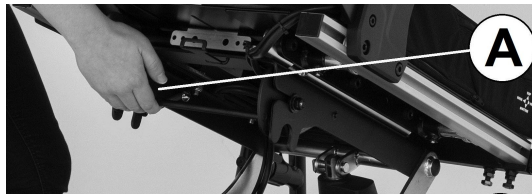

Release seat **A** and tilt forwards.

3. Disconnect remote bus cable from power module or ACT.
4. Lift seat out of front anchorage and remove it. The seat has a heavy weight. Use proper lifting techniques.
5. Remove both battery boxes (see 6.11.1 *Removing Battery Boxes*, page 55).
- 6.

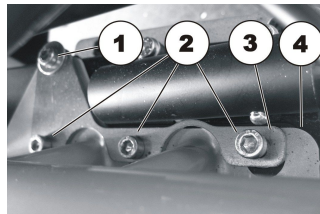

Undo and remove the four screws (1) & (2) on motor bracket which hold the fender (4) using a 5 mm Allen key.

7. Remove reinforcing plate (3).
8. Remove and replace fender.
- 9.

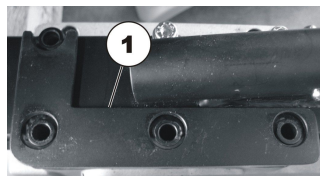

A further reinforcing plate (1) is located under the fender.

- 10.

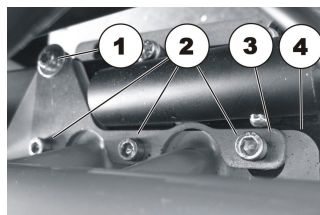

Install parts in reverse order. When reassembling, make sure that screw (1) is shorter than screw (2).

## 6.10 Controls

### 6.10.1 Replacing Power Module

Different combinations of power modules and remotes can be fitted to the mobility device. Power modules are described in earlier revisions of this service manual or in the LiNX service manual.

Replacement is described below using LiNX power module as an example. The course of action is the same for other power modules. The only difference is the terminal layout.



#### CAUTION!

**Any changes to drive program can affect driving characteristics and tipping stability of mobility device**

- Changes to drive program may only be carried out by trained providers.
- Invacare can only give a warranty for safe mobility device driving behavior - especially tipping stability - for unaltered standard drive programs.



All power modules are delivered with a standard drive program. If you have carried out customer-specific modifications to the drive program, you will have to make these changes again after installing new power module.



- Phillips screwdriver
- To adapt the drive program: Programming software or hand programming device and system installation manual, available from Invacare.

1. Turn off electronics on remote.
2. Remove legrests.
- 3.



Fig. 6-35

Release seat **A** and tilt forwards.

4. Disconnect remote bus cable from power module or ACT.
5. Lift seat out of the front anchorage and remove seat. The seat has a heavy weight. Use proper lifting techniques.
6. If fitted, remove front shroud. See 6.9.1 *Replacing Front Shroud*, page 48.
7. Take exact note of positions of all cables and the sockets that they are connected to. Mark the connectors and sockets or take a photograph with a digital camera.
- 8.

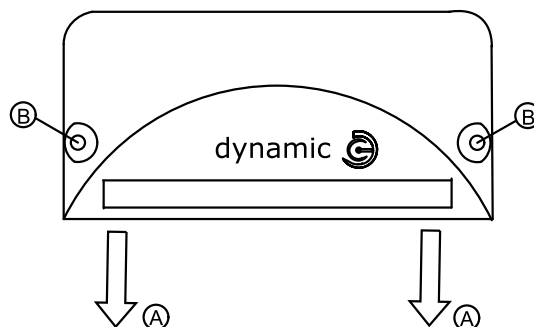

Fig. 6-36

Remove plugs **A** from power module.

9. Loosen and remove screws **B**.
10. Remove power module.
11. Install parts in reverse order.



For details on cable routing, see LiNX service manual.

12. Update drive program if a new software version is available. See 6.10.5 *Updating software*, page 54.
13. Adapt drive program using programming software if necessary.
14. If LiNX system is used, perform calibration process. See *Suggested programming procedure* in LiNX service manual.
15. Test all functions.

## 6.10.2 Replacing G-Trac Sensor



### CAUTION!

#### Risk of Crushing to Hands and Feet by Weight of Mobility Device

- Pay attention to hand and feet.
- Use proper lifting techniques.



- 5 mm Allen key
- 10 mm wrench

1. Turn off electronics.
2. Remove legrests.
3. If a removable seat is fitted, remove seat.



Fig. 6-37

- a. Release seat **A** and tilt forwards.
- b. Unplug remote bus cable from power module or actuator module.
- c. Lift seat out of front anchorage and remove it.
4. Remove parts that are in the way such as front shroud or batteries. See corresponding chapters.
- 5.

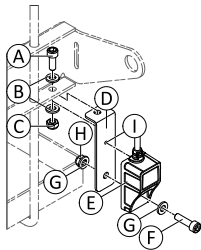

Fig. 6-38 G-Trac sensor on a model with a battery tray.

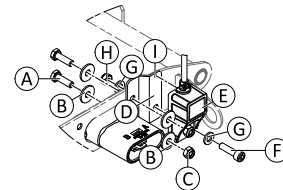

Fig. 6-39 G-Trac sensor on a model with detachable battery boxes.

Unplug sensor cable from power module.

6. Loosen and remove nut **C**
7. Remove sensor bracket **D** together with sensor **E**, washers **B** and bolt **A**.
8. Loosen and remove nut **H**, washers **G** and bolt **F**.
9. Remove sensor **E** from sensor bracket **D**.
10. Replace sensor.
11. Install parts in reverse order. Pay attention that sensor must be installed with cable pointing upwards. Sensor has a guide on its rear side that must fit exactly to hole **I**.
12. Test all functions.

## 6.10.3 Replacing Operating Hour Counter



- Size 2 Phillips screwdriver
- 10 mm open-end wrench

1. Turn off electronics.
2. Remove legrests.

3.



Fig. 6-40

Release seat (A) and tilt forward.

4. Disconnect remote bus cable from power module or ACT.
5. Lift seat up out of its forward mounting and remove it. The seat has a heavy weight. Use proper lifting techniques.
- 6.

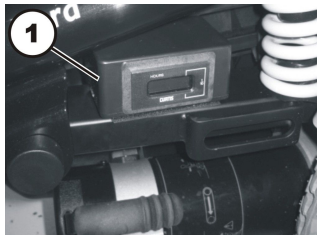

Fig. 6-41

The operating hour counter is attached to the frame with hook and loop.

7. Disconnect cable of operating hour counter from drive motor.
8. Pull operating hour counter off the frame.
9. Turn operating hour counter over.
10. Loosen and remove four Phillips head screws of the casing.
11. Disconnect plugs (+) & (-).
- 12.

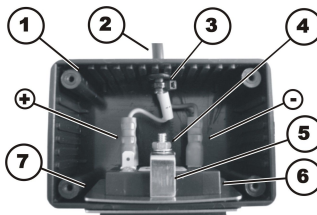

Fig. 6-42

Remove nut (4) including the locking washer.

13. Pull operating hour counter (6) forwards out of the casing (1). Pay attention to the mounting bracket (5) and the retaining frame (7).
14. Replace operating hour counter.



**CAUTION!**

**Risk of property damage if counter is wrongly connected. If the plus and minus wires are connected the wrong way, it will damage the electronic components of the operating hour counter.**

– Make sure the cable is connected correctly.

15.

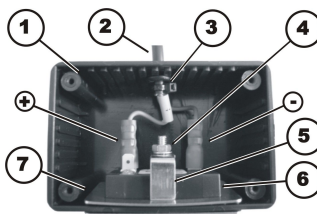

Fig. 6-43

Install parts in reverse order.

16. Connect plug on the blue wire (-) to the pin on operating hour counter which is marked with a “minus” symbol.
17. Connect plug on the brown wire (+) to the pin on operating hour counter which is marked with a “plus” symbol. The brown wire is additionally marked with a yellow sleeve with a “plus” symbol on it.
18. Close casing and reattach it to the mobility device with hook and loop fastening.
19. Install parts in reverse order.

## 6.10.4 Replacing Connecting Cable of Operating Hour Counter



- Size 2 Phillips screwdriver
- Side cutters
- Tie wraps

1. Turn off electronics.
2. Remove legrests.
- 3.



Fig. 6-44

Release seat **A** and tilt forward.

4. Disconnect remote bus cable from power module or ACT.
5. Lift seat up out of its forward mounting and remove it. The seat has a heavy weight. Use proper lifting techniques.
- 6.

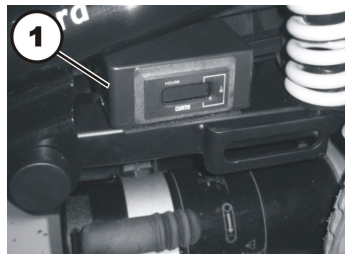

Fig. 6-45

The operating hour counter is attached to the frame with a hook and loop strip.

7. Disconnect cable of the operating hour counter from drive motor.
8. Pull operating hour counter off the frame.
9. Turn operating hour counter over.
10. Loosen and remove four Phillips head screws of the casing.
11. Disconnect plugs (+) & (-).
- 12.

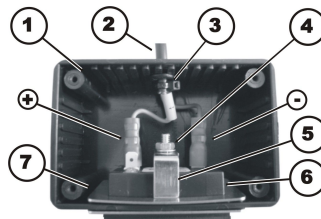

Fig. 6-46

Remove tie wraps (4).

13. Carefully pull connecting cable (2) of operating hour counter out of the casing (1).
14. Replace cable of operating hour counter.



### CAUTION!

Property damage can result if the counter is wrongly connected. If the plus and minus wires are connected the wrong way, it will damage the electronic components of the operating hour counter.  
– Make sure the cable is connected correctly.

15.

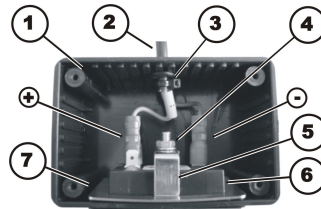

Fig. 6-47

The cable of the operating hour counter is installed in reverse order.

16. Connect plug on the blue wire (-) to the pin on the operating hour counter which is marked with a “minus” symbol.
17. Connect plug on the brown wire (+) to the pin on the operating hour counter which is marked with a “plus” symbol. The brown wire is additionally marked with a yellow sleeve with a “plus” symbol on it.
18. Secure cable with a cable tie (3), thereby protecting it from being pulled off unintentionally.
19. Close casing and reattach it to the mobility device with hook and loop fastening.
20. Install parts in reverse order.

### 6.10.5 Updating software

 For LiNX see LiNX Service Manual. For VR2, R-Net, Shark, ACS2 see revision 15 of this service manual.

## 6.11 Batteries



### CAUTION!

#### Injury hazard and possible material damages if batteries are handled improperly

The installation of new batteries may only be carried out by authorised specialists.

- Observe the warning information on the batteries.
- Only use battery versions stated in the specifications.



### CAUTION!

#### Fire and burns hazard if battery terminal is bypassed

– Take great care to ensure that the battery terminals are never short-circuited with tools or mechanical mobility device parts.

- Ensure that the battery terminal caps have been replaced if you are not working on the battery terminals.



### CAUTION!

#### Risk of crushing

Batteries can be extremely heavy. This results in injury hazards to your hands.

- Handle the batteries with care.
- Ensure that batteries do not fall to the ground when removed from chassis.
- Pay attention to hands.
- Use proper lifting techniques.



### WARNING!

#### Burn hazard

Injury hazard due to discharged acid.

- Always wear acid-proof protective gloves when handling batteries.
- Always wear protective goggles when handling batteries.

#### What to do if acid is discharged

- Always take clothing which has been soiled by or dipped in acid off immediately!
- Rinse any areas of your skin which has come into contact with battery acid off immediately with plenty of water!

#### If contact with eyes is made

- You should also consult an eye specialist immediately afterwards!

 When removing, take care of small parts such as screws and washers. Put all small parts down so that they can be installed in correct sequence.

### 6.11.1 Removing Battery Boxes



**CAUTION!**

**Risk of crushing**

- The batteries are extremely heavy. This results in injury hazards to your hands.
- Bear in mind that the batteries are sometimes very heavy.
  - Handle batteries with care.



A spare fuse is located behind the Invacare logo on the rear battery.

1.



Fig. 6-48

Pull rear battery box backwards using belt. The locking device opens automatically when doing so.

2.



Fig. 6-49

Pull battery boxes out using side handles.

3.



Fig. 6-50

Pull front battery box backwards using belt and pull it out using handles.

### 6.11.2 Replacing Batteries



**CAUTION!**

**Fire and burns hazard if battery terminal is bypassed**

- Take great care to ensure that the battery terminals are never short-circuited with tools or mechanical mobility device parts.
- Ensure that the battery terminal caps have been replaced if you are not working on the battery terminals.



- Phillips screwdriver

1.



Fig. 6-51

Bend tabs (1) on battery box shroud lightly to the outside and loosen shroud.

2.

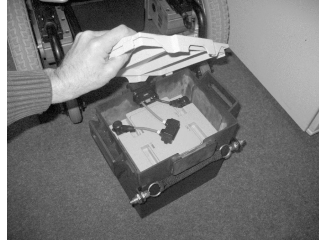

Fig. 6-52

Remove shroud to open battery box.

3.



Fig. 6-53

Pull battery box socket / plug out of guide.



Rear battery is only fitted with battery box socket at front.

Front battery is fitted with battery box socket at front (flange central) and with battery box plug at rear (flange flush).

4. Note fixing position of battery and battery box sockets/plugs.  
New battery must be refitted in exactly same position as old one.

5.



Fig. 6-54

Batteries can be pulled upwards out of battery boxes by their handles.

6.

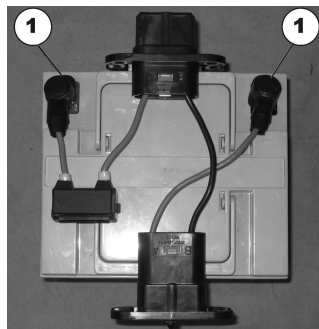

Fig. 6-55

Remove battery terminal caps from battery terminals (1).



7.

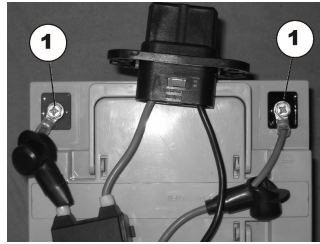

Fig. 6-56

Loosen battery terminal clamps (1).

8. Loosen screw on negative terminal (black cable).
9. Loosen screw on positive terminal (red cable).
10. Install parts in reverse order.
11. Make sure that battery box sockets/plugs have been correctly refitted. A polarity diagram is located in each battery box shroud.

**Front battery:**

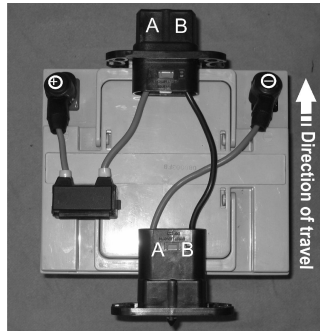

Fig. 6-57

The battery box socket is located at the front (flange central).

- Socket side Ⓐ is on the left in the direction of travel.
- Socket side Ⓑ is on the right in the direction of travel.

The battery box plug is located at the rear (flange flush).

- Plug side Ⓐ is on the left in the direction of travel.
- Plug side Ⓑ is on the right in the direction of travel.

**Rear battery:**

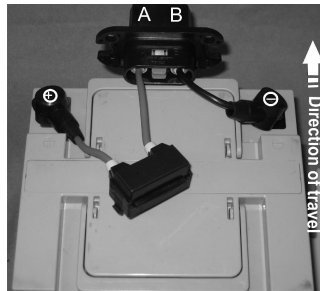

Fig. 6-58

The battery box socket is located at the front (flange central).

- Socket side Ⓐ is on the left in the direction of travel.
- Socket side Ⓑ is on the right in the direction of travel.

12. The battery needs to be inserted tightly into battery box. Use foam sections supplied.
13. Test all functions.

### 6.11.3 Removing Batteries from Battery Tray



**CAUTION!**

**Fire and burns hazard if battery terminal is bypassed**

- Take great care to ensure that the battery terminals are never short-circuited with tools or mechanical mobility device parts.
- Ensure that the battery terminal caps have been replaced if you are not working on the battery terminals.



**CAUTION!**  
**Risk of crushing**

The batteries are extremely heavy. This results in injury hazards to your hands.  
 – Bear in mind that the batteries are sometimes very heavy.  
 – Handle batteries with care.



- Phillips screwdriver
- 13 mm wrench

1.

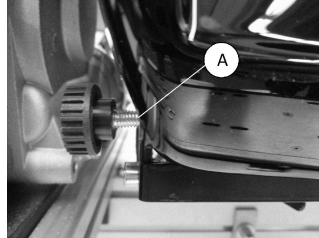

Fig. 6-59

Loosen and remove hand screws (A) on rear shroud.

2. Remove rear shroud.

3.

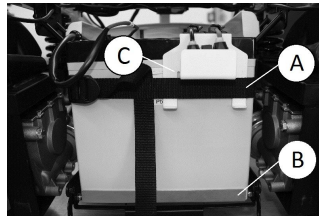

Fig. 6-60

Pull out battery tray (B).

4. Open battery belt (A) under fuse guide (C).

5.



Fig. 6-61

Note fixing position of battery and battery case sockets/plugs.

The new battery must be refitted in exactly the same position as the old one.



A polarity diagram is printed in the rear shroud.

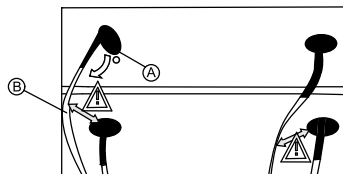

Fig. 6-62



**WARNING!**  
**Risk of shorts**

Contact between batteries causes shorts.

– Make sure that power cable (B) and battery terminal (A) do not have contact.

6.

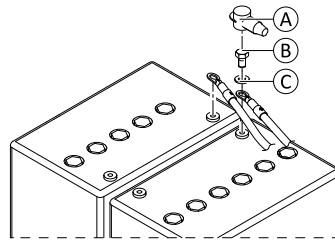

Fig. 6-63

Remove terminal caps (A).

7. Loosen and remove terminal screws (B) including washers (C).
  - First remove negative terminal screw.
  - After this, remove positive terminal screw.
8. Remove connection cable with main fuse.
9. Replace batteries.
10. Install parts in reverse order.
11. Make sure that all connections have been correctly refitted.
12. Test all functions.

#### 6.11.4 General Instructions on Handling Batteries

- Never mix and match different battery manufactures or technologies, or use batteries that do not have similar date codes.
- Never mix gel with AGM batteries.
- The batteries reach their end of life when the drive range is significantly smaller than usual. Contact your provider or service technician for details.
- Always have your batteries installed by a properly trained mobility device technician or a person with adequate knowledge. They have the necessary training and tools to do the job safely and correctly.

#### 6.11.5 Handling Damaged Batteries Correctly



##### CAUTION!

##### Corrosion and burns from acid leakage if batteries are damaged

– Remove clothes that have been soiled by acid immediately.

##### After contact with skin:

– Immediately wash affected area with lots of water.

##### After contact with eyes:

– Immediately rinse eyes under running water for several minutes; consult a physician.

- Always wear safety goggles and appropriate safety clothing when handling damaged batteries.
- Place damaged batteries in an acid-resistant receptacle immediately after removing them.
- Only ever transport damaged batteries in an appropriate acid-resistant receptacle.
- Wash all objects that have come into contact with acid with lots of water.

#### Disposing of Dead or Damaged Batteries Correctly

Dead or damaged batteries can be given back to your provider or directly to Invacare.

#### 6.11.6 Main Fuse



##### CAUTION!

##### Risk of fire

A short circuit can cause extremely high currents which can result in spark formation and fire.

- Always use an original strip fuse with the approved amperage.
- If the main fuse has blown, first rectify the cause before fitting a new one.



##### CAUTION!

##### Risk of fire and burns

Fitting incorrect strip fuse causes fire hazard.

- Only fix strip fuses in sequence shown in image below.
- Tighten nuts with 3.3 or 3.5 Nm.

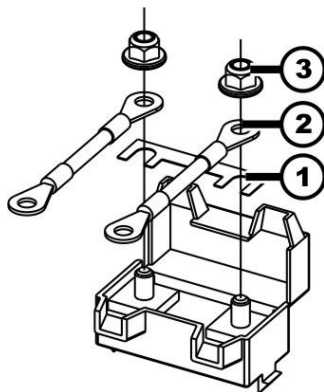





Fig. 6-64 Correct sequence of fitting original strip fuse

1	Strip fuse
2	Ring terminal
3	DIN 6923 nut

-  • 4 mm flat screwdriver
- Strip fuse
- 8 mm socket wrench
- Torque wrench 0-20 Nm (or similar)

 A spare fuse is located behind the Invacare logo on the rear battery.

 If the fuse holder is damaged, you can replace it completely with the battery cables.

#### Removing Main Fuse in Mobility Device with Battery Boxes

1. Turn off electronics on remote.
2. Remove both battery boxes. See 6.11.1 Removing Battery Boxes, page 55.
3. Remove shrouds on both battery boxes. See 6.11.2 Replacing Batteries, page 55.
- 4.

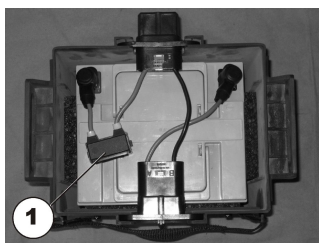

Fig. 6-65

Fuse holder (1) is located on top of batteries.

5.

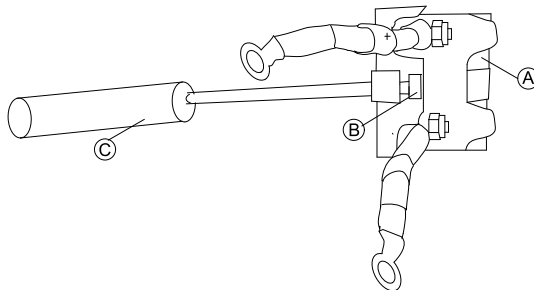



Fig. 6-66

Pry open snap hook **B** with flat screwdriver **C**. Fuse holder shroud **A** is open.

6. If strip fuse has blown, you must first ascertain and rectify the cause of the fault.
7. Main fuse may only be replaced once fault has been rectified.

 Older fuse holder versions may be locked with a cable tie. If so, cut open cable tie to access fuse strip.

8.

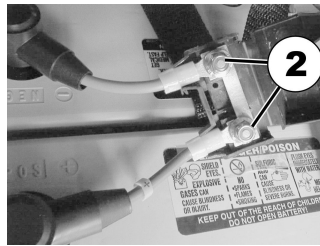

Fig. 6-67

Remove strip fuse nuts (2).

9. Remove strip fuse.

### Removing Main Fuse in Mobility Device Without Battery Boxes

1. Remove rear shroud. See 6.11.3 *Removing Batteries from Battery Tray*, page 57.

2.

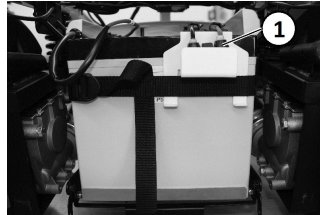

Fig. 6-68

Fuse holder (1) is located in fuse guide in front of batteries.

3.

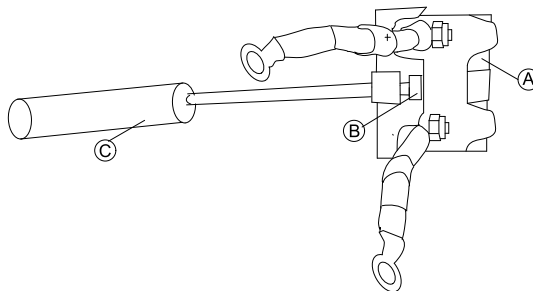

Fig. 6-69

Pry open snap hook (B) with flat screwdriver (C). Fuse holder shroud (A) is open.

4. If strip fuse has blown, you must first ascertain and rectify the cause of the fault.

5. Main fuse may only be replaced once fault has been rectified.



Older fuse holder versions may be locked with a cable tie. If so, cut open cable tie to access fuse strip.

6.

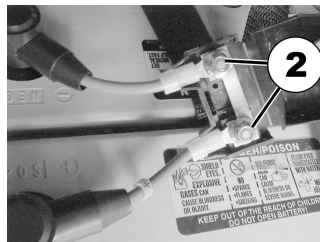

Fig. 6-70

Remove strip fuse nuts (2).

7. Remove strip fuse.

### Installing Main Fuse

1. Replace strip fuse.

2. Install parts in reverse order.



Make sure to press two parts of fuse holder shroud together until it snaps.



If older fuse holder version is used, lock fuse holder with UL94V0 cable tie.

3. Test all functions.

## 6.11.7 Checking Cables

The following images show checking the cables using LiNX electronics as an example. The plug positions are different for DX2 and VR2 electronics but the procedure for checking is identical.

For plug position, see corresponding electronics manual or earlier revision of this manual.

1. Remove legrests.
- 2.



Fig. 6-71

Release seat **A** and tilt forwards.

3. Check all cables for visible damage, crushing points or abrasion points.
4. Replace damaged cables.
- 5.

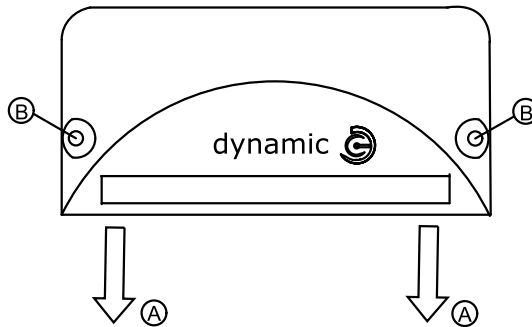



Fig. 6-72

Pull on each plug **A** carefully.

The plug must not come out of its socket when pulled on lightly.

6. If plug is loose, press plug into socket with slight pressure.  
The plug must snap in place securely.
7. Check that plug is firmly attached to its socket.
8. Remove both battery boxes. See 6.11.1 "Removing battery boxes", page 55.  
Remove shrouds on both battery boxes. See 6.11.2 Replacing Batteries, page 55.  
If mobility device is not fitted with battery boxes, access batteries. See 6.11.3 Removing Batteries from Battery Tray, page 57.
9. Check all battery cables for visible damage, crushing points or abrasion points. Replace damaged cables.
10. Install parts in reverse order.
11. Test all functions.

 For details on cable routing, see LiNX service manual.

## 6.12 Lighting Unit

### 6.12.1 Replacing headlight (LED light)

 Replacing an individual LED is not possible. If there is a defect, replace the entire front headlight.



Tools:

- 7 mm jaw spanner
- 3 mm Allen key
- Oblique pliers
- Cable binder

1. For position of the plugs see corresponding controls manual or earlier revision of this manual.
2. Remove legrests.

3.



Release seat **A** and tilt forwards.

4. Disconnect remote bus cable from power module or ACT.
5. Lift seat out of the front anchorage and remove it. The seat has a heavy weight. Use proper lifting techniques.
6. Remove both battery boxes (see 6.11.1 *Removing Battery Boxes*, page 55).
7. Remove front headlight plug from lighting PCB.
8. Free cable or remove any cable ties.
- 9.



Loosen nut (2) with a 7 mm jaw spanner and a 3 mm Allen key.

10. Remove front headlight (1) from lamp holder (3).
11. Install parts in reverse order.
12. Test all functions.

### 6.12.2 Replacing Front Lamp Holder (LED Light)



- 7 mm wrench
- 3 mm Allen key
- TX25 screwdriver
- Oblique pliers
- Tie wraps

1.



Fig. 6-73

Loosen nut (2) and remove.

2. Remove front headlight (1) from lamp holder (3) and place it carefully to the side.
- 3.



Fig. 6-74

Undo and remove screws (4) with a TX25 screwdriver.

4. Replace lamp holder (3).
5. Install parts in reverse order.
6. To complete, check all vehicle functions.

### 6.12.3 Replacing Rear Light (LED Light)



Replacing an individual LED is not possible. If there is a defect, replace the entire rear light.



- Phillips screwdriver
- TX40 Torx key
- Oblique pliers
- Tie wrap

1. For plug position, see corresponding controls manual or earlier revision of this manual.
2. Remove legrests.
- 3.



Fig. 6-75

Release seat **A** and tilt forwards.

4. Disconnect remote bus cable from power module or ACT.
5. Lift seat out of the front anchorage and remove it. The seat has a heavy weight. Use proper lifting techniques.
6. Remove both battery (see 6.11.1 *Removing Battery Boxes*, page 55)
7. Remove drive wheel (see *Replacing Drive Wheel (5-Screw Installation)*).
- 8.

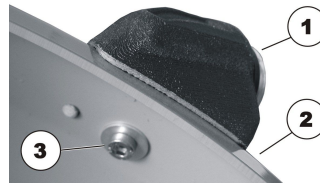

Fig. 6-76

Remove rear light plug from lighting PCB.

9. Free cable or remove any cable ties.
10. Undo Phillips screw (1) and remove it together with washer.
11. Remove rear light (1) from fender and replace it.
12. Install parts in reverse order.
13. To complete, check all vehicle functions.

## 6.13 Seating

This chapter deals with the replacement of interface components between the base of the mobility device and the corresponding seating system.

For detailed instructions on the seating system, see the service manual of the corresponding seating system.

### 6.13.1 Replacing Tilt Tube



#### CAUTION!

#### Risk of Crushing to Hands and Feet by Weight of Seat

- Pay attention to hand and feet.
- Use proper lifting techniques.



- Flat screwdriver
- Oblique pliers
- Tie wraps



### Making Tube Accessible

1. Remove legrests.
- 2.



Fig. 6-77

Release seat (1) and tilt seat forwards.

3. Unplug all cable connections between seat and chassis.
4. Lift seat out of front anchorage and remove seat.
5. Remove both battery boxes. See 6.11.1 *Removing Battery Boxes*, page 55.

### Removing Tube

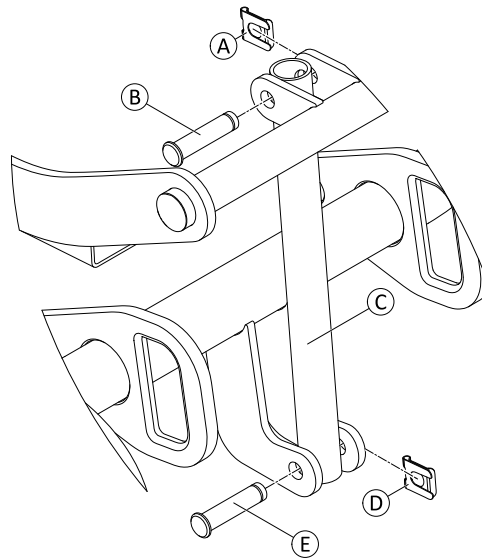

Fig. 6-78

1. Remove SL retainer clip **A** and **D** on tube at top and bottom.
2. Remove lower pin **E**. Hold seat support in position.
3. Lower seat support carefully to chassis.
4. Remove upper pin **B**.
5. Replace tube **C**.

### Installing Tube

1. Install parts in reverse order.
2. Test all functions.

### 6.13.2 Replacing actuator — powered tilt with fixed pivot point



When an electrical adjustment option is retrofitted, then this option needs to be activated in the driving program as well.



#### Tools:

- Flat screwdriver width approx. 6 mm blade
- Oblique pliers
- Small hammer
- Cable binder

### Example Bora

## Making tilt actuator accessible

1.



Remove legrests

2. Release seat (1) and tilt forwards.
3. Disconnect remote bus cable from power module or ACT.
4. Lift seat out of front anchorage and remove it. The seat has a heavy weight. Use proper lifting techniques.
5. Remove both battery cases (see "Removing battery cases" in service manual).
6. Pull actuator plug out of power module.
7. Actuator able is secured inside the frames with cable ties. Remove cable ties with oblique pliers.

## Replacing actuator

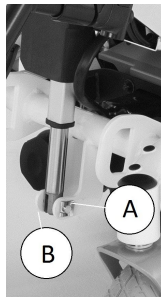

1. Remove SL retainer clip **B** on the bottom fixing bolt **A** with the screwdriver.
2. Remove SL retainer clip **B** on the bottom fixing bolt **A** with the screwdriver.
3. Pull fixing bolt **A** out.
- 4.

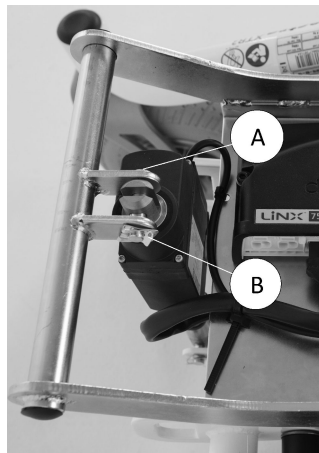

Remove SL retainer clip **B** on the top fixing bolt **A** with the screwdriver.

5. Pull fixing bolt **A** out.
6. Pull spindle with actuator out.

## Installing actuator

1. Reinsert fixing bolts and SL retainer clips. Fix SL retainer clips securely to fixing bolt with the hammer.
2. Secure actuator cable to the frame with cable ties. The cable must be routed so that it does not rub or get trapped.
3. To complete, check all seat tilting functions.

### 6.13.3 Replacing Seat Height Adapter

The adapter raises the seat-to-floor height of a Modulite seat. This allows you to mount the seat further to the back of the mobility device.



- Installation kit
- 13 mm wrench (2x)

1. Remove legrests.
- 2.



Fig. 6-79

3. Release seat **A** and tilt forwards.
- 4.

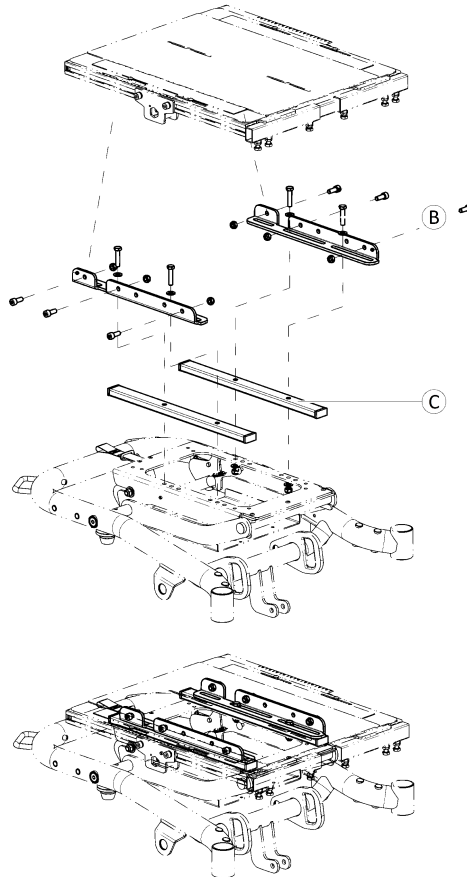

Fig. 6-80

5. Loosen and remove screws **B**.
6. Remove seat frame support **C**.

 Use long screws, delivered with installation kit, to fasten seat frame support.

7. Install parts in reverse order.
8. Test all functions.

## Invacare Sales Companies

### Australia:

Invacare Australia Pty. Ltd.  
1 Lenton Place, North Rocks NSW  
2151  
Australia  
Phone: 1800 460 460  
Fax: 1800 814 367  
orders@invacare.com.au  
www.invacare.com.au

### United Kingdom:

Invacare Limited  
Pencoed Technology Park, Pencoed  
Bridgend CF35 5AQ  
Tel: (44) (0) 1656 776 222  
Fax: (44) (0) 1656 776 220  
uk@invacare.com  
www.invacare.co.uk

### Canada:

Invacare Canada L.P.  
570 Matheson Blvd East, Unit 8  
CDN Mississauga, On. L4Z 4G4  
Phone: (905) 890 8300  
Toll Free: 800.668.5324  
www.invacare.ca

### Eastern Europe, Middle East & CIS:

Invacare EU Export  
Am Achener Hof 8  
D-88316 Isny  
Tel: (49) (0)7562 700 397  
eu-export@invacare.com  
www.invacare-eu-export.com

### Ireland:

Invacare Ireland Ltd,  
Unit 5 Seatown Business Campus  
Seatown Road, Swords, County Dublin  
Tel : (353) 1 810 7084  
Fax: (353) 1 810 7085  
ireland@invacare.com  
www.invacare.ie

### New Zealand:

Invacare New Zealand Ltd  
4 Westfield Place, Mt Wellington 1060  
New Zealand  
Phone: 0800 468 222  
Fax: 0800 807 788  
sales@invacare.co.nz  
www.invacare.co.nz



### Manufacturer:

Invacare Deutschland GmbH  
Kleiststraße 49  
D-32457 Porta Westfalica  
Germany

