

# Invacare® Comet Series

CometPRO, CometALPINE+, CometULTRA



en Scooter  
Service Manual



DEALER: Keep this manual.  
The procedures in this manual MUST be performed by a qualified technician.



**Yes, you can.®**

© 2019 Invacare Corporation

All rights reserved. Republication, duplication or modification in whole or in part is prohibited without prior written permission from Invacare. Trademarks are identified by ™ and ®. All trademarks are owned by or licensed to Invacare Corporation or its subsidiaries unless otherwise noted.

---

# Contents

---

<b>1 General</b> . . . . .	<b>4</b>
1.1 Introduction . . . . .	4
1.2 General Information . . . . .	4
1.3 Notes on Shipping . . . . .	4
1.4 Symbols in this manual . . . . .	4
1.5 Images in This Manual . . . . .	4
<b>2 Safety</b> . . . . .	<b>5</b>
2.1 Safety information . . . . .	5
2.2 Safety and Fitting Instructions . . . . .	5
<b>3 Hygiene</b> . . . . .	<b>7</b>
3.1 Handling of Returned Used Products . . . . .	7
<b>4 Setup</b> . . . . .	<b>8</b>
4.1 Operating console (LED version) . . . . .	8
4.1.1 Entering setup (LED Display) . . . . .	8
4.1.2 Setting Battery Gauge . . . . .	9
4.2 Operating console (LCD version) . . . . .	9
4.2.1 Entering setup (LCD Display) . . . . .	10
4.2.2 Setting counter . . . . .	10
4.2.3 Setting Battery Gauge . . . . .	10
4.2.4 Setting wheel diameter . . . . .	11
<b>5 Service</b> . . . . .	<b>12</b>
5.1 General safety information on installation work . . . . .	12
5.2 Troubleshooting . . . . .	12
5.2.1 Operational faults . . . . .	12
5.2.2 Drive fault diagnosis . . . . .	12
5.2.3 Error Codes And Diagnostic Codes . . . . .	13
5.3 Tightening Torques . . . . .	14
5.4 Service plan (1x annually) . . . . .	14
5.5 Controls . . . . .	15
5.5.1 Replacing Operating Console . . . . .	15
5.5.2 Replacing Circuit Board . . . . .	16
5.5.3 Replacing Potentiometer . . . . .	16
5.5.4 Replacing lifter/lifter controls . . . . .	17
5.5.5 Replacing power module . . . . .	18
5.6 Shrouds . . . . .	19
5.6.1 Removing shroud . . . . .	19
5.6.2 Replacing front shroud . . . . .	19
5.7 Lighting unit . . . . .	20
5.7.1 Replacing headlight . . . . .	20
5.7.2 Replacing front direction indicators . . . . .	20
5.7.3 Replacing center brake light . . . . .	21
5.7.4 Replacing rear lights/direction indicators . . . . .	21
5.8 Wheels . . . . .	22
5.8.1 Replacing wheel suspension . . . . .	22
5.8.2 Replacing shock absorber . . . . .	23
5.8.3 Replacing swing arm . . . . .	24
5.8.4 Replacing steering column . . . . .	24
5.8.5 Replacing Front Wheel Suspension (4-Wheel Version) . . . . .	25
5.8.6 Replacing and Adjusting Central Rear Shock Absorber . . . . .	26
5.8.7 Repairing tire punctures . . . . .	27
5.9 Brakes . . . . .	27
5.9.1 Replacing hand brakes . . . . .	27
5.9.2 Replacing brake cable . . . . .	28
5.9.3 Replacing steering link/coupling rod . . . . .	28
5.9.4 Replacing curve control device . . . . .	29
5.10 Drive Components . . . . .	30
5.10.1 Replacing drive unit . . . . .	30
5.10.2 Replacing carbon brushes . . . . .	32
5.11 Seat . . . . .	32
5.11.1 Replacing seat suspension/spring . . . . .	32
5.11.2 Replacing seat support tube . . . . .	33
<b>6 Accessories</b> . . . . .	<b>34</b>
6.1 Accessories List . . . . .	34

# 1 General

## 1.1 Introduction

This document contains important information about assembly, adjustment and advanced maintenance of the product. To ensure safety when handling the product, read this document and the user manual carefully and follow the safety instructions.

Find the user manual on Invacare's website or contact your Invacare representative. See addresses at the end of this document.

Invacare reserves the right to alter product specifications without further notice.

Before reading this document, make sure you have the latest version. You find the latest version as a PDF on the Invacare website.

For pre-sale and user information, see the user manual.

For more information about the product, for example product safety notices and product recalls, contact your Invacare representative. See addresses at the end of this document.

## 1.2 General Information

- Service and maintenance work must be carried out taking this service manual into account.
- It is imperative that you observe safety information.
- Information about operation or about general maintenance and care work on the mobility device should be taken from service manual.
- You can find information about ordering spare parts in the spare parts catalogue.
- Spare parts must match original Invacare parts. Only use spare parts which have been approved by Invacare.
- We reserve the right to make any alterations on the grounds of technical improvements.
- For more information about the product, for example product safety notices and product recalls, contact your local Invacare representative. For address and website see back page of this manual.
- The mobility device may only be maintained and overhauled by qualified personnel.
- The minimum requirement for service technicians is suitable training, such as in the cycle or orthopedic mechanics fields, or sufficiently long-term job experience.
  - Experience in the use of electrical measuring equipment (multimeters) is also a requirement.
  - Special Invacare training is recommended.

- Alterations to the mobility device which occur as a result of incorrectly or improperly executed maintenance or overhaul work lead to the exclusion of all liability on the side of Invacare.
- If you have any problems or questions contact your provider.

## 1.3 Notes on Shipping

- If the mobility device has to be shipped back to the manufacturer for major repairs, you should always use the original packaging for transport.
- Please attach a precise description of the fault.

## 1.4 Symbols in this manual

Symbols and signal words are used in this manual and apply to hazards or unsafe practices which could result in personal injury or property damage. See the information below for definitions of the signal words.



### WARNING

Indicates a hazardous situation that could result in serious injury or death if it is not avoided.



### CAUTION

Indicates a hazardous situation that could result in minor or slight injury if it is not avoided.



### IMPORTANT

Indicates a hazardous situation that could result in damage to property if it is not avoided.



### Tips

Gives useful tips, recommendations and information for efficient, trouble-free use.



### Tools

Identifies required tools, components and items which are needed to carry out certain work.

## 1.5 Images in This Manual

The detailed images in this manual are given marks to identify various components. Component marks in text and operational instructions always relate to the image directly above.



## 2 Safety

### 2.1 Safety information



**WARNING!**

The procedures in this service manual, must be performed by a specialized dealer or qualified service technician.

- Do not handle this product or any available optional equipment without first completely reading and understanding these instructions and any additional instructional material such as user manuals, installation manuals or instruction sheets supplied with this product or optional equipment.



The information contained in this document is subject to change without notice.

### 2.2 Safety and Fitting Instructions

These safety instructions are intended to prevent accidents at work, and it is imperative that they are observed.

#### Before any inspection or repair work

- Read and observe this repair manual and the associated user manual.
- Observe the minimum requirements for carrying out the work (see 1.2 *General Information, page 4*).

#### Personal Safety Equipment

##### Safety shoes

The mobility device, and some of its components, are very heavy. These parts can result in injuries to the feet if they are allowed to drop.

- Wear standardized safety shoes during all work.

##### Eye protection

It is possible that battery acid can be discharged when working on defective batteries or when handling batteries improperly.

- Always wear eye protection when working on any defective or possibly defective batteries.

##### Safety gloves

It is possible that battery acid can be discharged when working on defective batteries or when handling batteries improperly.

- Always wear acid-proof safety gloves when working on any defective or possibly defective batteries.

### General Safety Information and Information About Fitting / Removal



**DANGER!**

**Risk of Death, Serious Injury, or Damage**

Lighted cigarettes dropped onto an upholstered seating system can cause a fire resulting in death, serious injury, or damage. Mobility device occupants are at particular risk of death or serious injury from these fires and resulting fumes because they may not have the ability to move away from the mobility device.

- DO NOT smoke while using this mobility device.



**WARNING!**

**Risk of Serious Injury or Damage**

Storing or using the mobility device near open flame or combustible products can result in serious injury or damage.

- Avoid storing or using the mobility device near open flame or combustible products.



**CAUTION!**

**Risk of crushing**

Various components such as the drive unit, batteries, seat etc are very heavy. This results in injury hazards to your hands.

- Note the high weight of some components. This applies especially to the removal of drive units, batteries and the seat.



**CAUTION!**

**Injury hazard if the mobility device starts moving unintentionally during repair work**

- Switch the power supply off (ON/OFF key).
- Engage the drive.
- Before lifting up, secure the mobility device by using chocks to block the wheels.



**CAUTION!**

**Fire and burn hazard due to electrical short-circuit**

- The mobility device must be completely switched off before removal of voltage-carrying components! To do this, remove the batteries.
- Avoid short-circuiting the contacts when carrying out measurements on voltage-carrying components.



**CAUTION!**

**Risk of burns from hot surfaces on the motor**

- Allow the motors to cool down before commencing work on them.



**CAUTION!**

**Injury hazard and risk of damage to mobility device due to improper or incomplete maintenance work**

- Use only undamaged tools in good condition.
- Some moving parts are mounted in sockets with PTFE coating (Teflon™). Never grease these sockets!
- Never use "normal" nuts instead of self-locking nuts.
- Always use correctly-dimensioned washers and spacers.
- When reassembling, always replace any cable ties which were cut during dismantling.
- After completing your work / before renewed start-up of the mobility device, check all connections for tight fitting.
- After completing your work / before renewed start-up of the mobility device, check all parts for correct locking.
- Only operate the mobility device with the approved tyre pressures (see technical data).
- Check all electrical components for correct function. Note that incorrect polarity can result in damage to the control system.
- Always carry out a trial run at the end of your work.



**CAUTION!**

**Risk of injury and damage to property, if the maximum speed reduction on a wheelchair with a lifter does not function correctly**

- The wheelchair's control unit must reduce the maximum possible speed as soon as the lifter is raised.
- Test the maximum speed reduction for correct function after any maintenance work or modifications to the wheelchair.



**CAUTION!**

**Any changes to the drive program can affect the driving characteristics and the tipping stability of the mobility device**

- Changes to the drive program may only be carried out by trained Invacare providers.
- Invacare supplies all mobility devices with a standard drive program ex-works. Invacare can only give a warranty for safe mobility device driving behavior - especially tipping stability - for this standard drive program.



Mark all current settings for the mobility device (seat, armrests, backrest etc.), and the associated cable connecting plugs, before dismantling. This makes reassembly easier. All plugs are fitted with mechanical locks which prevent release of the connecting plugs during operation. To release the connecting plugs the safety locks must be pressed in. When reassembling ensure that these safety locks are correctly engaged.

## 3 Hygiene

### 3.1 Handling of Returned Used Products

When reconditioning or repairing returned mobility devices:

- Take precautions for yourself and the product.
- Use protection equipment as specified locally.

#### Before Transport (According to Biological Agents Ordinance)

Treat product according to following process steps:

Process Step	Component	Application	Conditioning technique	Work Station
Manual cleaning	Surface of used device	Before repair or reconditioning	Use saturated towel to apply cleaning detergent and remove residues after impact.	Cleaning and disinfection
Disinfection	Surface of used device	Before repair or reconditioning	Use saturated disinfectant wipes and clean* the device surface.	Cleaning and disinfection

\*Invacare uses detergent "Nücosept special" 1.5% in water ml/ml

#### Disinfection Tools

- Disposable wipes (fleece)
- Brushes to clean areas difficult to access

#### Further Information

 For more information contact your Invacare service department.

## 4 Setup

### 4.1 Operating console (LED version)

#### Arrangement

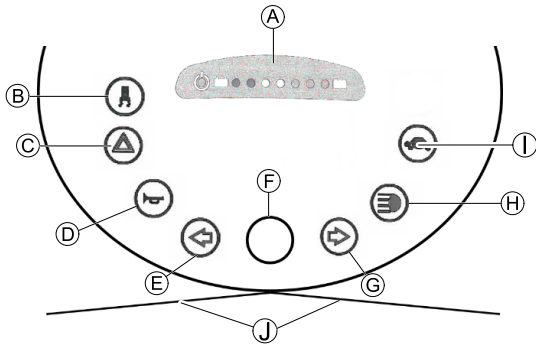

Fig. 4-1

(A)	Status display
(B)	Switching on/off curve control (reduction of speed when driving in a curve)
(C)	Hazard lights
(D)	Horn
(E)	Left-hand direction indicator (switches itself off automatically after 30 seconds)
(F)	Speed control dial
(G)	Right-hand direction indicator (switches itself off automatically after 30 seconds)
(H)	Lighting
(I)	Low speed mode
(J)	Drive lever

#### Status Display

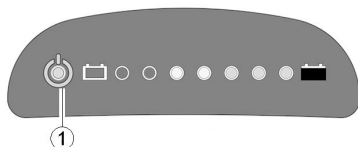

Fig. 4-2

**i** The ON/OFF diode (1) is used as a fault display (status display). It will flash if there is a problem with the scooter. The number of flashes indicates the type of error. Refer to 5.2.3 *Error Codes And Diagnostic Codes*, page 13.

#### Battery Indication Gauge

**i** Low battery indication: Every time the scooter is activated or at work when battery capacity is lower than 25%, the electronic system will beep three times.

**i** Overdischarge protection: after a certain drive time on reserve battery power the electronic system switches the drive off automatically and brings the scooter to a standstill. If you do not drive your scooter for a while the batteries will "recuperate" and allow a further, but short, journey. However, after a very brief journey the battery reserve symbol will illuminate again and the electronic system will beep three times. This procedure leads to battery damage and should be avoided if possible!

Battery capacity: <25 %	Reduced driving range. Recharge the batteries at the end of your journey.
Battery capacity: <20 %	Battery reserve = severely restricted driving range. Recharge batteries immediately!

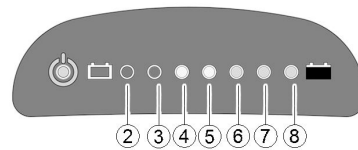

Fig. 4-3

(2)	(3)	(4)	(5)	(6)	(7)	(8)	Battery capacity
☀	☀	☀	☀	☀	☀	☀	>80 %
☀	☀	☀	☀	☀	☀		<80 %
☀	☀	☀	☀	☀			<65 %
☀	☀	☀	☀				<50 %
☀	☀	☀					<35 %
☀	☀						<25 %
☀							<20 %

#### 4.1.1 Entering setup (LED Display)

**i** This chapter applies for mobility devices with LED display.

1. Turn key to switch mobility device off.
- 2.



Press and hold keys.

3. Turn key to switch mobility device on. Mobility device enters setup mode after two seconds. LED 2 and LED 8 will flash.
- 4.



Release keys to enter setup settings.

### 4.1.2 Setting Battery Gauge

This chapter applies for mobility devices with LED display.

Setting battery gauge is mandatory when retrofitting operating console.

Adjust the parameter in battery gauge to suit different types and sizes of batteries.

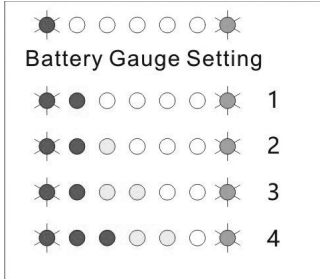

AGM battery		Gel battery	
(1) small size batteries (≤ 50 Ah, default)	(2) big size batteries (> 50 Ah)	(3) small size batteries (≤ 50 Ah)	(4) big size batteries (> 50 Ah)

1.



Press key to change settings.

2. Save settings by waiting for 10 seconds or pressing any other keys except keys above.

## 4.2 Operating console (LCD version)

### Arrangement

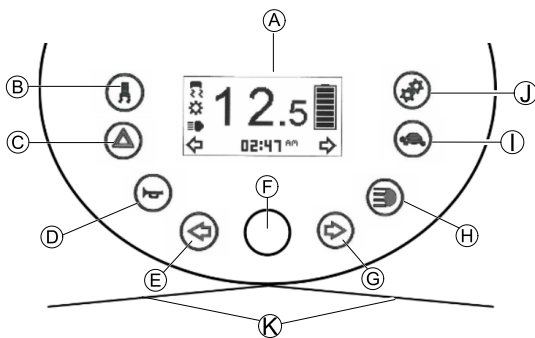

(A)	Status display
(B)	Switching on/off curve control (reduction of speed when driving in a curve)
(C)	Hazard lights
(D)	Horn
(E)	Left-hand direction indicator (switches itself off automatically after 30 seconds)
(F)	Speed control dial

(G)	Right-hand direction indicator (switches itself off automatically after 30 seconds)
(H)	Lighting
(I)	Low speed mode
(J)	Setting
(K)	Drive lever

### Status display



(A)	Speed indication
(B)	Fault indication
(C)	Curve control indication
(D)	Maintenance indication <sup>1</sup>
(E)	Head light indication
(F)	Left turn indication
(G)	Settings shown: ODO, TRIP, TEMP, TIME
(H)	Right turn indication
(I)	Battery status
(J)	Low speed selection indication

<sup>1</sup>If this symbol starts flashing for one minute every time the scooter is switched on, contact your provider.

### Battery indication gauge

Low battery indication: Every time the scooter is activated or at work when battery capacity is lower than 25%, the electronic system will beep three times.

Overdischarge protection: after a certain drive time on reserve battery power the electronic system switches the drive off automatically and brings the scooter to a standstill. If you do not drive your scooter for a while the batteries will "recuperate" and allow a further, but short, journey. However, after a very brief journey the battery reserve symbol will illuminate again and the electronic system will beep three times. This procedure leads to battery damage and should be avoided if possible!

Battery capacity: <25%	Reduced driving range. Recharge the batteries at the end of your journey.
Battery capacity: <20%	Battery reserve = severely restricted driving range. Recharge batteries immediately!

>80%	<80%	<65%	<50%	<35%	<25%	<20%

### 4.2.1 Entering setup (LCD Display)

This chapter applies for mobility devices with LCD display.

1. Turn key to switch mobility device off.
- 2.



Press and hold keys.

3. Turn key to switch mobility device on. Mobility device enters setup mode after two seconds.

		Enter next display with key.
		Enter next display with key.
		Enter next display with key.

### 4.2.2 Setting counter

This chapter applies for mobility devices with LCD display.

1. Enter setup settings as described in 4.2.1 Entering setup (LCD Display), page 10.

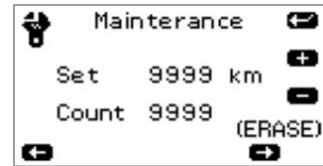

Default setting is 0. You can set a km value as service interval.

If counter value is greater than set value, symbol will flash for one minute, when key is switched on.

+	0 (OFF) + 500 + 1000 +1500 + 2000 ..... + 9500 + 9999 (max)
-	9999 - 9500 - 9000 - 8500 - 8000 ..... - 500 - 0 (OFF)

- 2.



Press and hold key for 2 sec. to erase counter.

- 3.



Press key to increase value.

- 4.



Press key to decrease value.

- 5.



Press key to save and enter next page.

### 4.2.3 Setting Battery Gauge

This chapter applies for mobility devices with LCD display.

Setting battery gauge is mandatory when retrofitting operating console.

Adjust the parameter in battery gauge to suit different types and sizes of batteries.

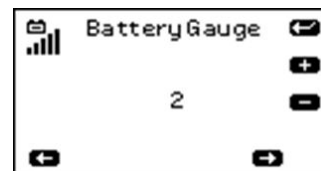

AGM battery		Gel battery	
(1) small size batteries (≤ 50 Ah, default)	(2) big size batteries (> 50 Ah)	(3) small size batteries (≤ 50 Ah)	(4) big size batteries (> 50 Ah)

1. 

Press key to increase value.

2. 

Press key to decrease value.

3. 

Press key to save and enter next page.

#### 4.2.4 Setting wheel diameter

 This chapter applies to mobility devices with LCD display.

 Setting wheel diameter is mandatory when retrofitting operating console.

Set value according to wheel diameter 11", 12", 13", 14" or 15" for correct display of speed.



1. 

Press key to increase value.

2. 

Press key to decrease value.

3. 

Press key to save and leave setup settings.

## 5 Service

### 5.1 General safety information on installation work



#### Risk of damage to mobility device

Collisions can be caused if shim rings are removed from the drive wheels during installation work. Shim rings are frequently placed between drive shaft and wheel hub to compensate tolerances. Collisions can be caused if these shim rings are removed and not re-installed.

- Install all shim rings in exactly the same positions they were in before dismantling.

## 5.2 Troubleshooting

### 5.2.1 Operational faults

Proceed as follows if you have any problems:

1. First assess the possible cause of the problem using the following table.
2. Check operating console status display. Evaluate flash code.
3. Carry out necessary checks and repairs as recommended in the following table.

### 5.2.2 Drive fault diagnosis

Problem	Other symptoms	Possible cause	Solution	Documentation
<b>Scooter will not start</b>	Status display on operating console does not illuminate	Batteries defective	Replace batteries	See user manual
		Completely discharged battery	Pre-charge batteries	
		Power supply to operating console interrupted	Check main fuse	See user manual for main fuse position
		Operating console defective	Check cable between modules for loose connections or damage	See <i>Replacing power module</i>
		Replace operating console	See <i>5.5.1 Replacing Operating Console, page 15</i>	
	Status display on operating console flashing	Various causes	Assess error code	See controls user manual
<b>Scooter judders in drive mode</b>	None	Drive motor(s) defective	Replace motor(s)	See
		Drive lever potentiometer defective	Replace potentiometer	See <i>5.5.3 Replacing Potentiometer, page 16</i>
<b>Batteries not being charged</b>	None	Batteries defective	Replace batteries	See user manual
	LEDs flashing on charger	Charger defective	Replace charger	See charger user manual
<b>Scooter runs too slowly</b>	None	Operating console defective	Replace operating console	See <i>5.5.1 Replacing Operating Console, page 15</i>
		Batteries defective	Replace batteries	See user manual
<b>Scooter does not reduce speed on bends</b>	None	Curve control device for bend travel not adjusted	Adjust curve control device	
		Curve control device defective	Replace curve control device	See <i>5.9.4 Replacing curve control device, page 29</i>



### 5.2.3 Error Codes And Diagnostic Codes

Flash code	Fault	Consequence for the scooter	Comments
1	Batteries must be charged	Continues to drive	<ul style="list-style-type: none"> <li>The batteries are discharged. Charge the batteries as soon as possible.</li> </ul>
2	Battery voltage too low	Stops driving	<ul style="list-style-type: none"> <li>The batteries are depleted. Charge batteries.</li> <li>If you switch the scooter off for a few minutes, the batteries can often recuperate to such a stage that a short journey is still possible. You should only do this in an emergency, however, because this causes the batteries to become excessively discharged.</li> </ul>
3	Battery voltage too high	Stops driving	<ul style="list-style-type: none"> <li>The battery voltage is too high. If the battery charger is connected, disconnect it from the scooter.</li> <li>The electronic system charges the batteries when running downhill and when braking. This fault is caused when the battery voltage becomes too high during this process. Switch the scooter off and on again.</li> </ul>
4	Power time exceeded	Stops driving	<ul style="list-style-type: none"> <li>The maximum current was exceeded over too long a period, probably because the motor was overloaded or has been working against an immovable resistance. Switch the scooter off, wait a few minutes and then switch on again.</li> <li>The electronic system has determined a motor short-circuit. Check the wiring harness for short-circuit and check the motor.</li> <li>Contact your Invacare provider.</li> </ul>
5	Brake failure	Stops driving	<ul style="list-style-type: none"> <li>Ensure that the disengaging lever is in the engaged position.</li> <li>There is a defect in the braking coil or in the cabling. Check the magnetic brake and cabling for open or short-circuited circuitry. Contact your Invacare provider.</li> </ul>
6	No neutral position when switching scooter on.	Stops driving	<ul style="list-style-type: none"> <li>Drive lever is not in neutral when the keyswitch was turned. Put the drive lever in neutral, turn the power off and then turn on again.</li> <li>It may be necessary to replace the drive lever. Contact your Invacare provider.</li> </ul>
	Circuit board failure	Stops driving	<ul style="list-style-type: none"> <li>Circuit board got damaged while connecting or disconnecting the charger to the charger socket.</li> <li>Test resistance of drive lever to eliminate a defective lever.</li> <li>It may be necessary to replace the circuit board or drive lever. Contact your Invacare provider.</li> </ul>
7	Fault in speed potentiometer	Stops driving	<ul style="list-style-type: none"> <li>The drive lever controls could be faulty or incorrectly connected. Check the cabling for open or short-circuited circuitry.</li> <li>Potentiometer is not correctly adjusted and must be replaced. Contact your Invacare provider.</li> </ul>
8	Motor voltage error	Stops driving	<ul style="list-style-type: none"> <li>The motor or its cabling is defective. Check the cabling for open or short-circuited circuitry.</li> </ul>
9	Miscellaneous internal fault	Stops driving	<ul style="list-style-type: none"> <li>Contact your Invacare provider.</li> </ul>
10	Push/freewheel mode error	Stops moving	<ul style="list-style-type: none"> <li>The scooter has exceeded the permissible maximum speed during pushing or freewheeling. Switch the electronics system off and on again.</li> </ul>

### 5.3 Tightening Torques

**CAUTION!**

**Risk of damage to mobility device due to improperly tightened screws, nuts or plastic connections.**

- Always tighten screws, nuts etc. to the stated tightening torque.
- Only tighten screws or nuts which are not listed here fingertight.

The tightening torques stated in the following list are based on the thread diameter for the nuts and bolts for which no specific values have been determined. All values assume dry and de-greased threads.

Thread	Tightening Torque in Nm $\pm 10\%$
M4	3 Nm
M5	6 Nm
M6	10 Nm
M8	25 Nm
M10	49 Nm
M12	80 Nm
M14	120 Nm
M16	180 Nm

### 5.4 Service plan (1x annually)

Component	Check	Remedy	Notes	✓
<b>Seat</b>	Check welded seams, fixings and upholstery	Tighten screws, replace parts if damaged		
	Check seat suspension	Grease the spring generously, replace parts if damaged	See <i>Replacing seat suspension/spring</i>	
<b>Frames (chassis) / battery mounting</b>	Check fixings, welded seams and battery mounting	Tighten screws, replace parts if damaged		
	Check battery fixing straps			
<b>Wheel suspension and wheels</b>	Check drive wheels for tight fit	Tighten hub nuts, replace if necessary		
	Check front wheels for tight fit, float and side play	Adjust / replace		
	Check pneumatic tire	Repair or replace if damaged	See user manual	
	Check tracking and steering link	Tighten screws		
Check tracking and steering				
<b>Brake</b>	Check brake function in pushing mode	Adjust or replace brake		
<b>Shock absorber</b>	Check shock absorber	Adjust or replace shock absorber		
<b>Drive units, coupling mechanism</b>	Check functions in drive and push modes	Replace motor if necessary		
	Check clutch mechanism	Tighten screws / nuts, adjust or replace		
<b>Lighting</b>	Check function			
	Check cable/plug connections	Replace lightbulbs or cable		

Component	Check	Remedy	Notes	✓
Batteries	Check batteries for damage	Replace batteries	See user manual	
	Check battery voltage	Charge batteries	See user manual	
	Check contacts and terminals	Clean contacts and terminals		
Drive controls	Check status display (flashing)	Evaluate flash code		
	Check fixing	Tighten or replace fixing		
	Check cable, connecting plug	Replace cable, connecting plug		
	Check drive lever function	Replace drive lever		
	Check power supply	Replace cable, connecting plug or console		
Drive program	Check drive program version. New version available?	Update software		
Curve control in bends	Check cable and connecting plug	Adjust or replace sensor on curve control device		
	Check function			
Screws	Check screws for tight fit	Tighten screws if necessary		

## 5.5 Controls

### 5.5.1 Replacing Operating Console



**CAUTION!**

**Risk of burns if power cable is shorted**

- Turn off the power completely before removing any power supply components of mobility device. Therefore take out batteries.
- Avoid bridging of contacts during measurements on live electrical components.



**CAUTION!**

**Risk of damage to operating console/circuit board by instant high current/voltage**

- Unplug battery cable before removing/installing operating console.
- Make sure all pins are correctly connected.



**Risk of Damaging Circuit Board by Electrostatic Discharge**

- Handle circuit boards only in Electrostatic Protected Areas (EPA).



The plugs on the operating console cannot be wrongly connected because all plugs have a different size and only fit in one socket.



- Phillips screwdriver



Setting battery gauge is mandatory when retrofitting operating console.



Setting wheel diameter is mandatory when retrofitting operating console.

1. Remove seat.
2. Remove shroud.
- 3.

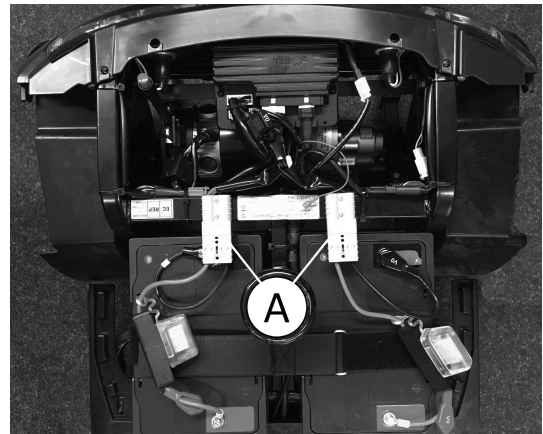

Disconnect battery cable (A).

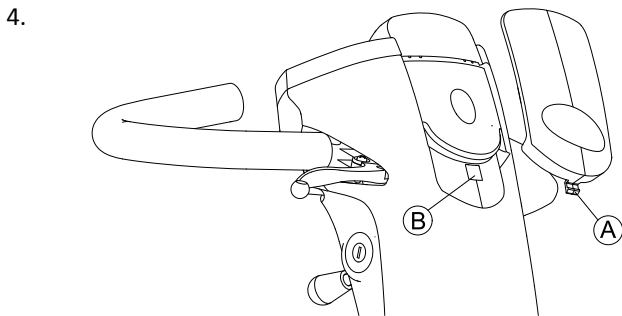

Remove top shroud (A) from steering column (B).

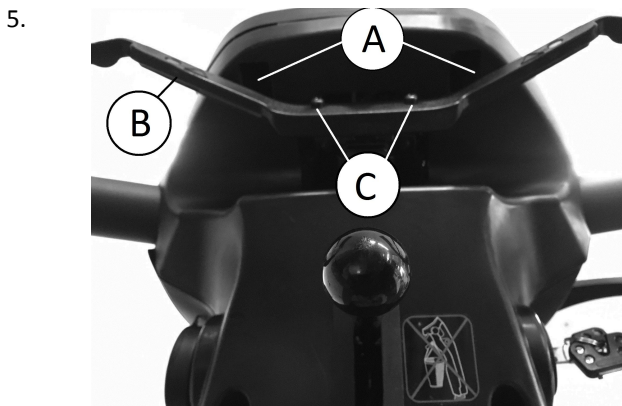

Remove screws (A) below operating console.  
 6. Remove operating console and fold upwards.  
 7. Remove screws (C) on drive lever (B) and remove drive lever.

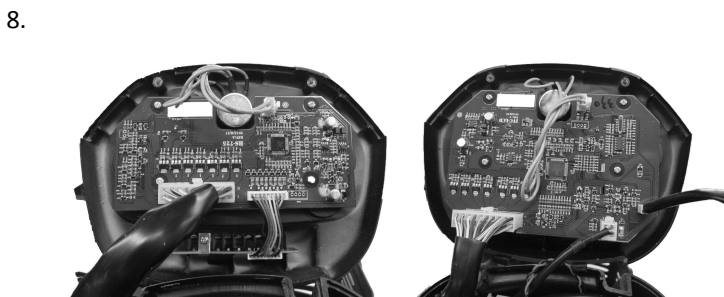

LED  
Fig. 5-1

LCD  
Fig. 5-2

Disconnect plug from operating console circuit board.

9. Replace operating console.
10. Connect plug with circuit board on new operating console.
11. Install parts in reverse order.
12. Test all functions (trial run).

### 5.5.2 Replacing Circuit Board



**CAUTION!**  
**Risk of burning if power cable is shorted**  
 – Turn off power completely before removing any power supply components of mobility device. Therefore take out batteries.  
 – Avoid bridging of contacts during measurements on live electrical components.



**CAUTION!**  
**Risk of damage to operating console/circuit board by instant high current/voltage**  
 – Unplug battery cable before removing/installing circuit board.  
 – Make sure all pins are correctly connected.



**Risk of Damaging Circuit Board by Electrostatic Discharge**  
 – Handle circuit boards only in Electrostatic Protected Areas (EPA).

1. Unplug battery connector.
- 2.



Remove operating console as described in chapter 5.5.1 *Replacing Operating Console*, page 15.

3. Replace circuit board.
4. Make sure all pins are correctly connected.
5. Plug in battery connectors.
6. Install parts in reverse order.
7. Test circuit board function.

### 5.5.3 Replacing Potentiometer



**CAUTION!**  
**Risk of burning if power cable is shorted**  
 – Turn off the power completely before removing any power supply components of the mobility device. Therefore take out batteries.  
 – Avoid bridging of contacts during measurements on live electrical components.



**CAUTION!**  
**Risk of damage to operating console by instant high current/voltage**  
 – Unplug battery cable before removing/installing operating console.  
 – Make sure all pins are correctly connected.



**CAUTION!**  
**Risk of accident**  
 Wrong potentiometer setting can result in dangerous driving situations.  
 – Connect potentiometer to drive lever mounting.



**Risk of Damaging Circuit Board by Electrostatic Discharge**  
 – Handle circuit boards only in Electrostatic Protected Areas (EPA).



- Phillips screwdriver
- 2 mm Allen key
- Digital multimeter



Before replacing the potentiometer check resistance of it. In some cases a defective circuit board produces the same failures.

1. Remove seat.
2. Remove shroud.
- 3.

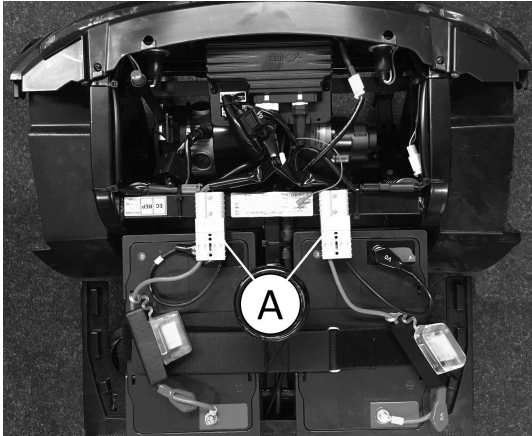

Disconnect battery cable (A).

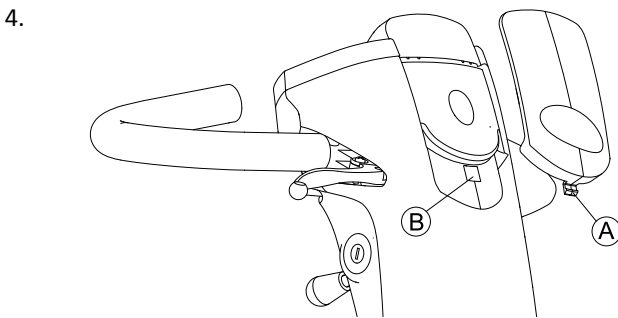

Remove top shroud (A) from steering column (B).



Remove screws (A) below operating console.

6. Remove operating console and fold upwards.
7. Remove screws (C) on drive lever (B) and remove drive lever.
- 8.

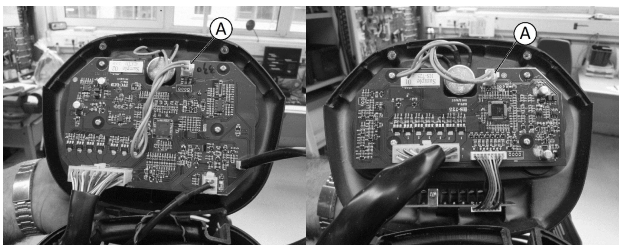

LCD  
Fig. 5-3

LED  
Fig. 5-4

Disconnect potentiometer plug (A) from operating console.

9.

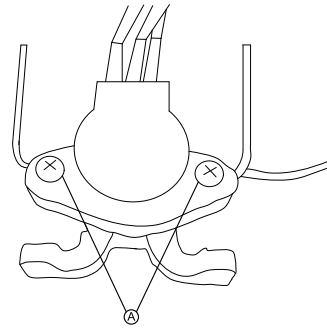

Remove screws (A) on potentiometer.

10. Replace potentiometer.
- 11.

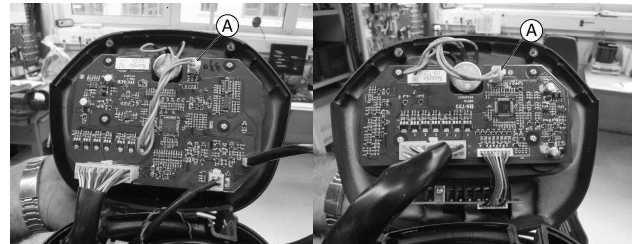

LCD  
Fig. 5-5

LED  
Fig. 5-6

Reconnect potentiometer plug (A) with operating console.

12.

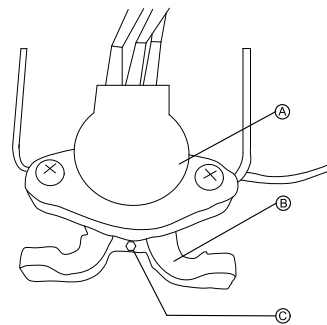

Connect potentiometer (A) and drive lever mounting (B):

- Tighten screw (C).

13. Install parts in reverse order.
14. Test all functions (trial run).

### 5.5.4 Replacing lifter/lifter controls



**CAUTION!**

**Risk of accident**

Accidental rolling can lead to accidents.

– Secure mobility device against rolling away.



When disassembling, note position of small parts such as screws and washers. Put small parts down so that they can be reassembled in right sequence.



- 14 mm wrench
- Phillips screwdriver

1. Secure mobility device against rolling away.
2. Remove seat.



3. Remove shroud.

4.

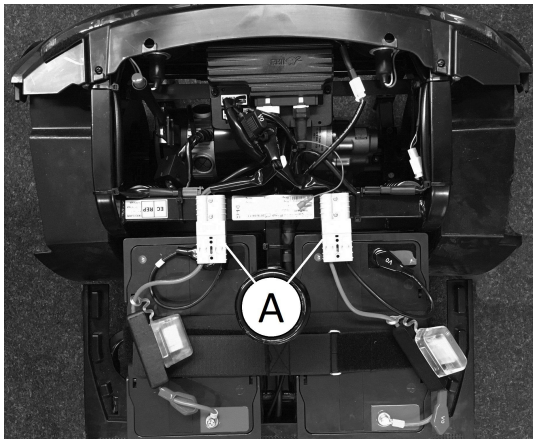

Disconnect battery plugs (A).

### Replacing lifter

1. Remove batteries.
2. Disconnect lifter cable at wiring harness connecting plug in motor enclosure.
- 3.

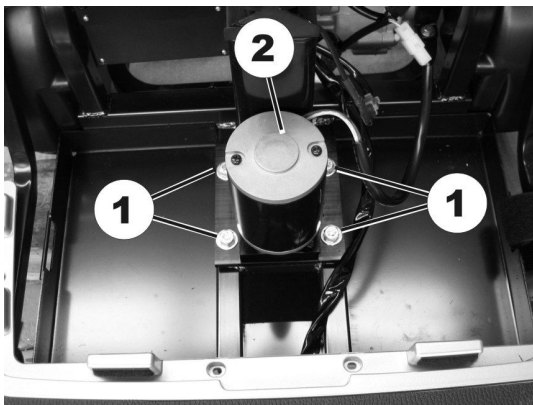

Remove screws (1) on lifter (2).

4. Replace lifter.
5. Install parts in reverse order.
6. Test all functions.

### Replacing lifter controls

1.

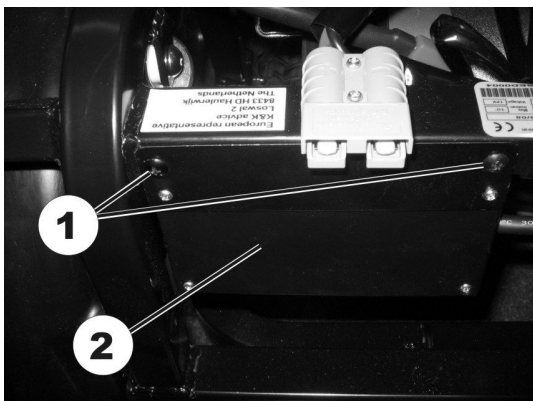

Remove both screws (1) from lifter controls (2).

2. Replace lifter controls (2).
3. Install parts in reverse order.
4. Test all functions.

### Replacing fuses in lifter controls

1. Loosen and remove screws on lifter controls shroud.
- 2.

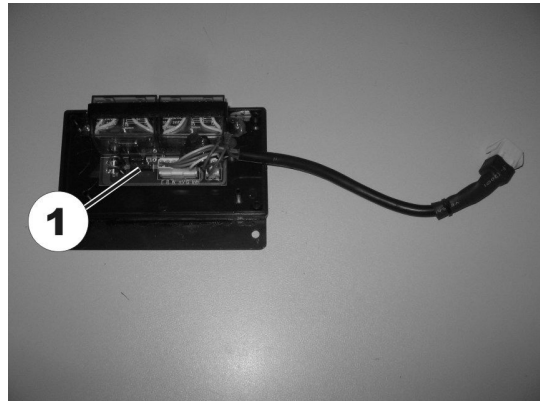

Replace fuse (1).

3. Install parts in reverse order.
4. Test all functions.

### 5.5.5 Replacing power module



#### CAUTION! Risk of accident

When parking mobility device on antitippers it is no longer slowed by motor brake. Mobility device can roll away out of control.

- Place mobility devices' rear frame on a supporting wooden block before you remove wheels.



#### CAUTION! Risk of burning if power cable is shorted

– Turn off power completely before removing any power supply components of mobility device. Therefore take out batteries.

- Avoid bridging of contacts during measurements on live electrical components.



#### CAUTION! Any changes to the drive program can affect the driving characteristics and the tipping stability of the mobility device.

- Changes to drive program may only be carried out by trained Invacare® specialist providers.
- Invacare® can only give a warranty for safe mobility device driving behaviour - especially tipping stability - for unaltered standard drive programs.



#### CAUTION! Risk of accident. Accidental rolling can lead to accidents.

- Secure mobility device against rolling away.



The controls system is supplied with a standard drive program. If you have carried out customer-specific modifications to the drive program, you will have to make these changes again after installing the new power module.



When disassembling, note position of small parts such as screws and washers. Put small parts down so that they can be reassembled in right sequence.

 The plugs on power module cannot be wrongly connected because all plugs have a different size and only fit in one socket.



- 10 mm wrench
- 17 mm wrench
- Rubber hammer
- Phillips screwdriver
- Supporting wooden block
- To adapt the drive program: programming software or hand programming device and controls system installation manual, available from Invacare.

1. Secure mobility device against rolling away.
2. Place supporting wooden block under frames at battery holder height.
3. Remove seat.
4. Remove shroud.
- 5.

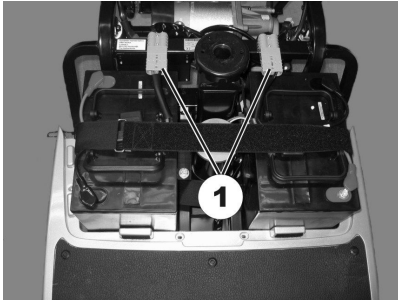

Disconnect battery cable (1).

6. Remove rear wheel fixing screws.
7. Remove rear wheels.
8. Remove drive unit. See 5.10.1 Replacing drive unit, page 30.
9. Remove screws (1) on power module (2).

- Rhino1:

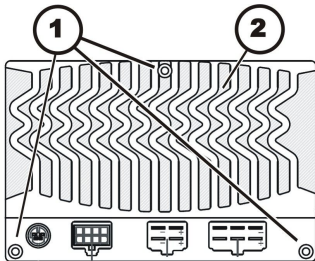

Fig. 5-7 DS112KB02/DS162KD01

- Rhino 2:

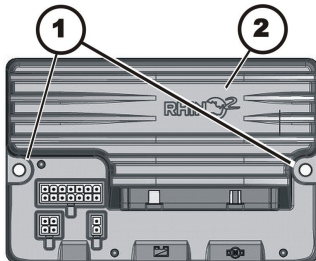

Fig. 5-8 DS120

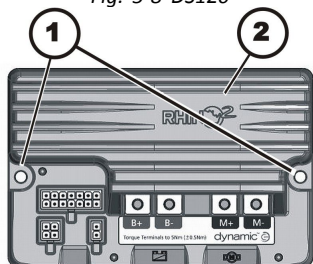
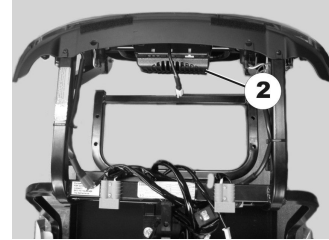

Fig. 5-9 DS160

10.



Replace power module (2).

11. Install parts in reverse order.
12. Load drive program onto power module. See controls software description.
13. Test all functions (trial run).

## 5.6 Shrouds

### 5.6.1 Removing shroud



**CAUTION!**

**Risk of damage to shroud**

- Do not pull shroud straight up to remove.
- Follow instructions below.

1.

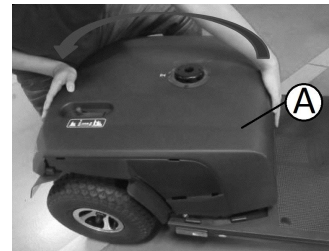

Place one hand at the front, the other at the rear of the shroud A.

2. Lift shroud up from front.

3.



Place hands on left and right side of shroud.

4. Twist and lift to remove shroud completely.

### 5.6.2 Replacing front shroud



- 10 mm socket wrench
- Phillips screwdriver

1. Remove rear shroud. See 5.6.1 *Removing shroud*, page 19.
- 2.

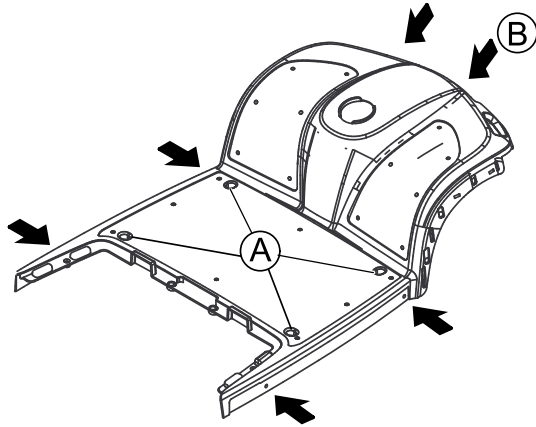

Remove four caps (A).

3. Loosen and remove screws (B).
4. Take off front shroud.
5. Install parts in reverse order.

## 5.7 Lighting unit

### 5.7.1 Replacing headlight

 You can replace headlight without removing the chassis. If, however, the working space is too small, you can remove the chassis as described in chapter 5.8.4 *Replacing steering column*, page 24.

 • Phillips screwdriver

1. Remove seat.
2. Remove shroud.
- 3.

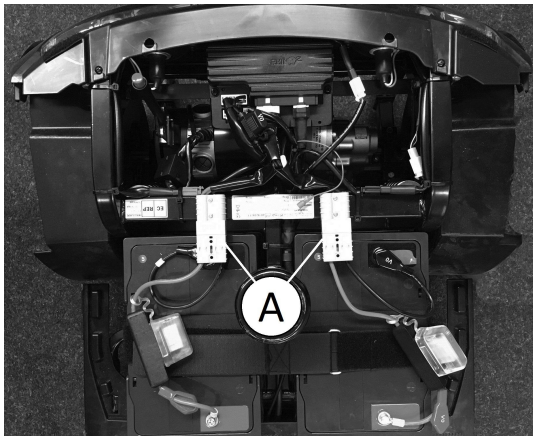

Disconnect battery cable (A).

4. Remove rear steering column shroud. See 5.8.4 *Replacing steering column*, page 24.

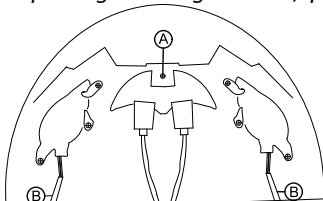

5. Remove screw (A) on headlight under front shroud.

6. Disconnect direction indicator cable (B) at wiring harness behind steering column shroud.

7.

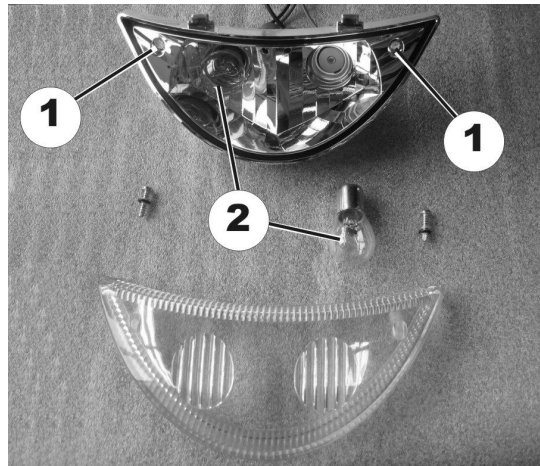

Remove headlight.

8. Remove screws (1) on headlight glass.
9. Remove headlight glass.
10. Replace bulb (2) in headlight.
11. Install parts in reverse order.
12. Test all functions.

### 5.7.2 Replacing front direction indicators

 • Phillips screwdriver

1. Remove seat.
2. Remove shroud.
- 3.

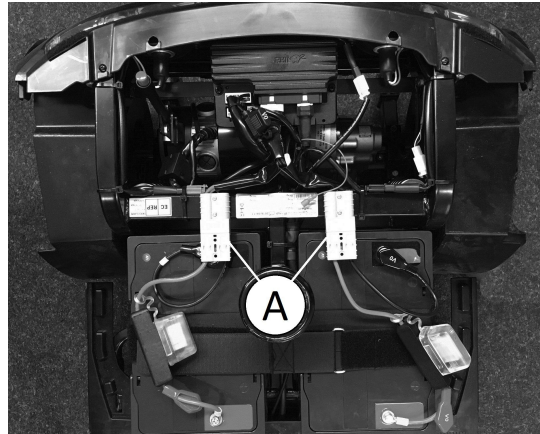

Disconnect battery cable (A).

4.

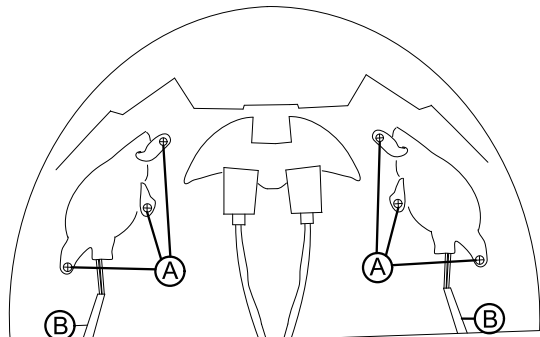

Remove direction indicator screw (A) on housing.

5. Disconnect direction indicator cable (B) from wiring harness.



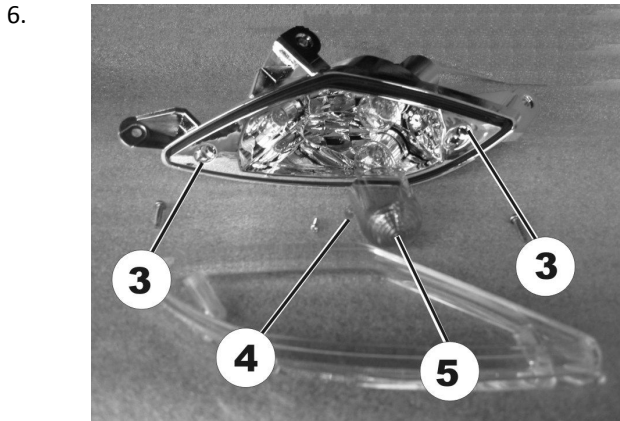

6. Remove screws (3) on indicator glass.
7. Remove indicator glass.
8. Loosen screws (4) on orange-colored cap (5) and remove cap.
9. Replace lightbulb.
10. Install parts in reverse order.
11. Test functions.

### 5.7.3 Replacing center brake light



**CAUTION!**

**Risk of burns if power cable is shorted**

- Turn off the power completely before removing any power supply components of the mobility device. Therefore take out the batteries.
- Avoid bridging of contacts during measurements on live electrical components.



When disassembling, note the position of small parts such as screws and washers. Put small parts down so that they can be reassembled in the right sequence.



- Phillips screwdriver

1. Remove seat.
2. Remove shroud.
- 3.

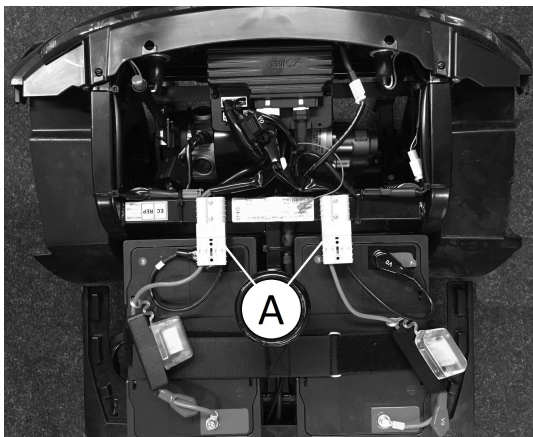

Disconnect battery cable (A).

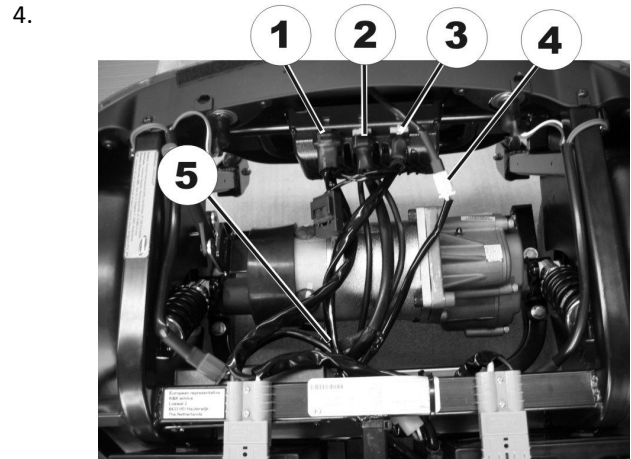

Disconnect plug (4).

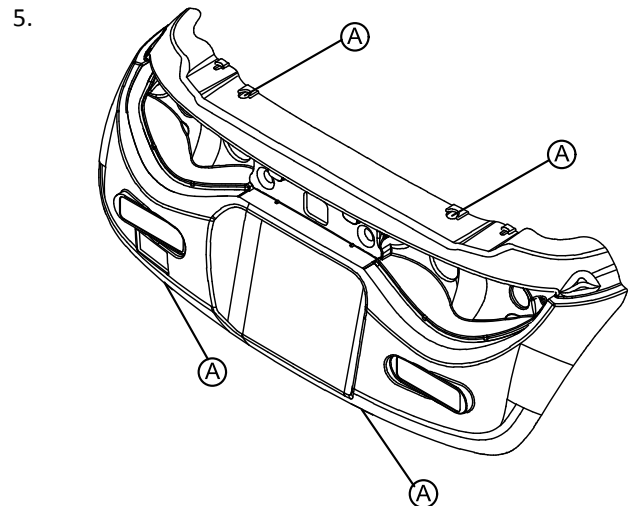

Remove bolts (A) on rear shroud.

6. Lift rear shroud upwards.
- 7.



Remove screws (1) on brake light.

8. Replace brake light.
9. Install parts in reverse order.
10. Test functions (trial run).

### 5.7.4 Replacing rear lights/direction indicators



**CAUTION!**

**Risk of burns if power cable is shorted**

- Turn off the power completely before removing any power supply components of the mobility device. Therefore take out the batteries.
- Avoid bridging of contacts during measurements on live electrical components.

 When disassembling, note the position of small parts such as screws and washers. Put small parts down so that they can be reassembled in the right sequence.

-  • Phillips screwdriver

1. Remove seat.
2. Remove shroud.
- 3.

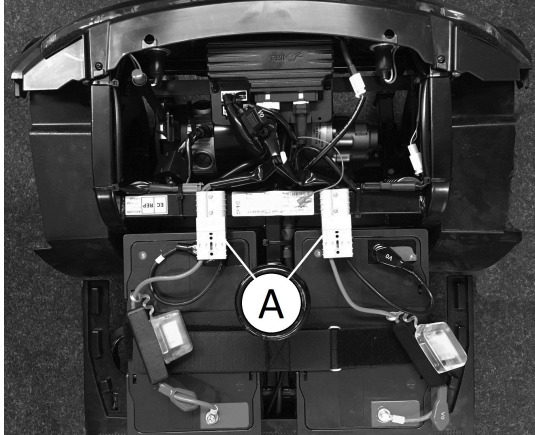

Disconnect battery cable (A).

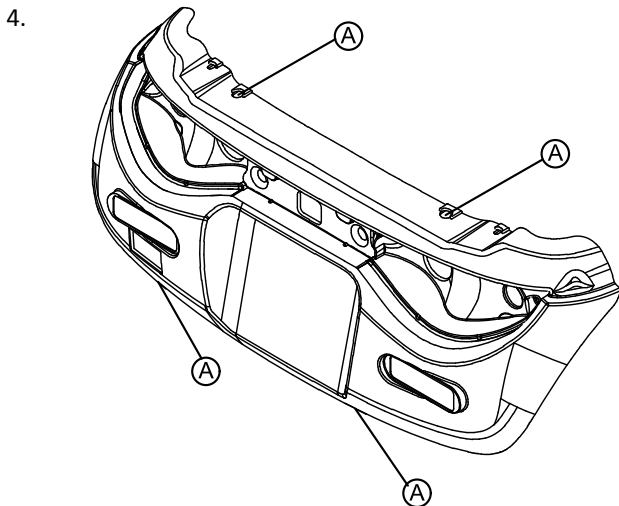

Remove bolts (A) on rear shroud.

5. Lift the rear shroud upwards.
- 6.

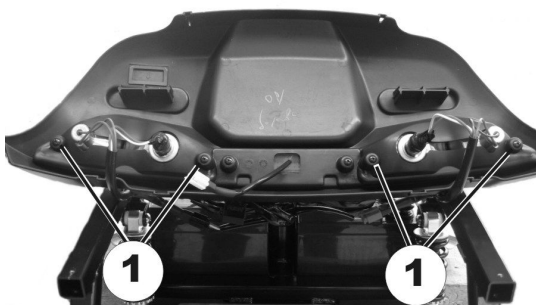

Remove screws (1) on rear light.

7. Remove rear light.
- 8.

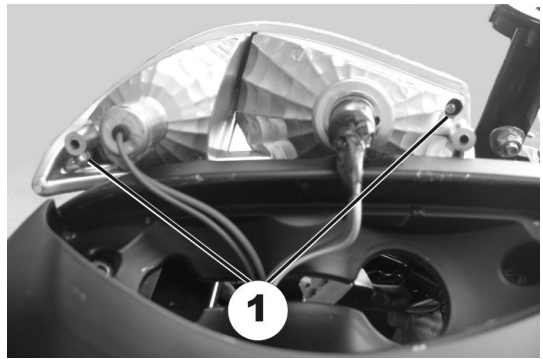

Remove screws (1) on rear light glass.

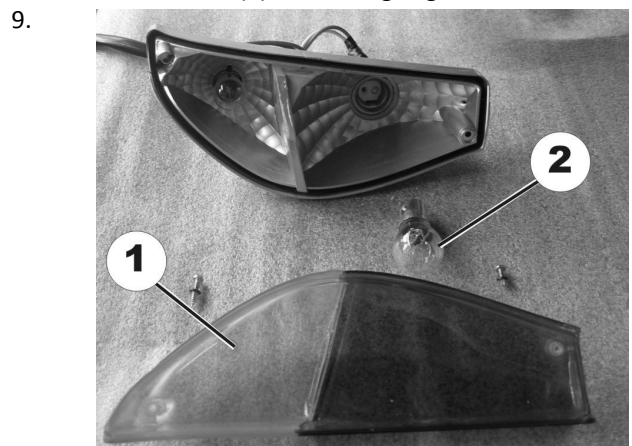

Remove rear light glass (1).

10. Replace lightbulbs (2).
11. Install parts in reverse order.
12. Test function.

## 5.8 Wheels

### 5.8.1 Replacing wheel suspension



**CAUTION!**

**Risk of accident**

Accidental rolling can lead to accidents.  
– Secure scooter against rolling away.



When disassembling, note the position of small parts such as screws and washers. Put small parts down so that they can be reassembled in the right sequence.



- 32 mm wrench
- Phillips screwdriver
- Supporting wooden block

1. Remove seat.
2. Remove shroud.

3.

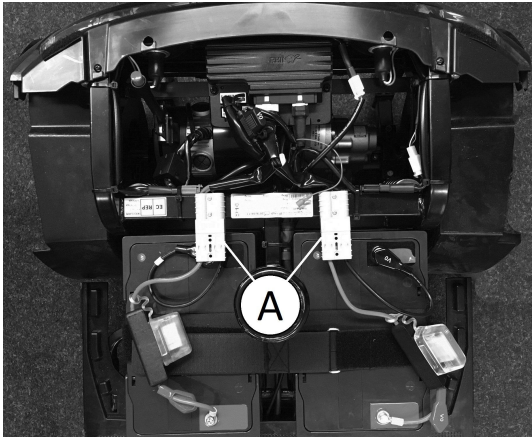

Disconnect battery cable (A).

4. Dismantle steering link and coupling rod. See 5.9.3 *Replacing steering link/coupling rod, page 28.*

5.

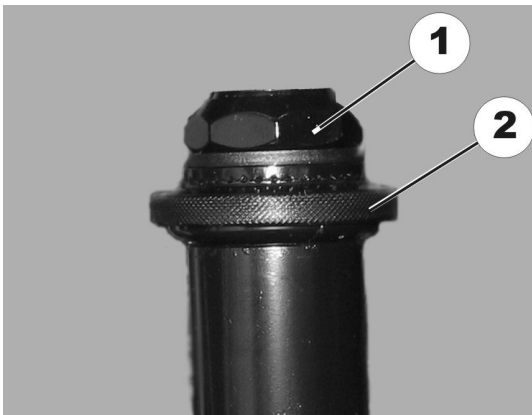

Loosen wheel suspension screw (1).

6. Loosen screw (2).

7. Replace wheel suspension.

8. Install parts in reverse order.

 Tighten screw (1) to 25 Nm.

9. Apply brake, tighten wheel bolts at same time.

10. Adjust tracking. See 5.9.3 *Replacing steering link/coupling rod, page 28.*

11. Test all functions (trial run).

### 5.8.2 Replacing shock absorber



**CAUTION!**  
**Risk of accident**

When parking mobility device on antitippers, mobility device is no longer slowed by motor brake. Mobility device can roll away out of control.

- Place mobility device rear frame on a supporting wooden block before you remove wheels.



**CAUTION!**  
**Risk of accident.**

Accidental rolling can lead to accidents.

- Secure mobility device against rolling away.



When disassembling, note the position of small parts such as screws and washers. Put small parts down so that they can be reassembled in the right sequence.



The drive motor needs to be removed before you can replace the left-hand shock absorber. If the right-hand shock absorber is to be replaced, you do not need to remove the drive motor.



- 10 mm wrench
- 17 mm wrench
- Phillips screwdriver
- 5 mm Allen keys (2x)
- Supporting wooden block

1. Remove wheel (see user manual)
2. Remove mud guard. See 5.10.1 *Replacing drive unit, page 30.*

#### Replacing rear shock absorber

1.

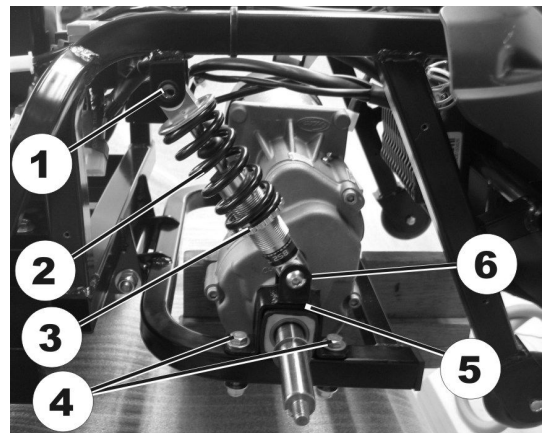

Remove top screw (1) on shock absorber (2).

2. Remove both screws (4) from motor bracket (5).

3. Remove shock absorber (2) with motor bracket (5).

4. Remove bottom screw (6) on shock absorber (2).

5. Replace shock absorber (2).

6. Install shock absorber in reverse order.

7. Use setting screw (3) to set spring hardness.

8. Test all functions (trial run).

#### Replacing front shock absorber

1.

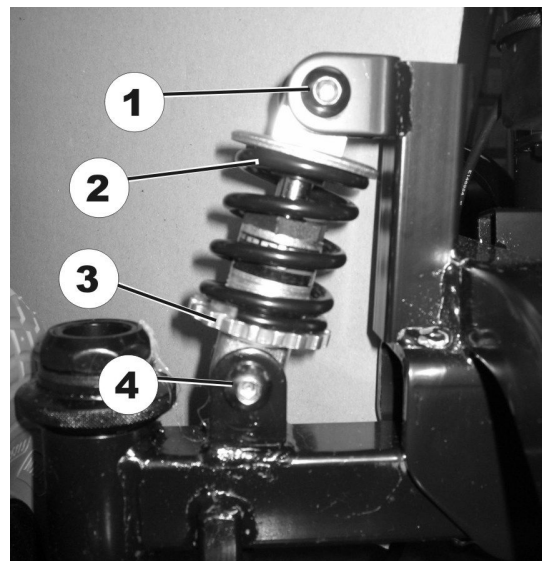

Remove top screw (1) on shock absorber (2).

2. Remove bottom screw (4) on shock absorber (2).

3. Replace shock absorber (2).



4. Install parts in reverse order.
5. Use setting screw (3) to set spring hardness.
6. Test all functions (trial run).

### 5.8.3 Replacing swing arm

-  • 14 mm wrench  
• 5 mm Allen key

1. Remove rear shroud.
2. Remove motor and differential gear. See chapter 4.10.1 Replacing drive unit, page 28.
3. Remove batteries. See user manual.
- 4.

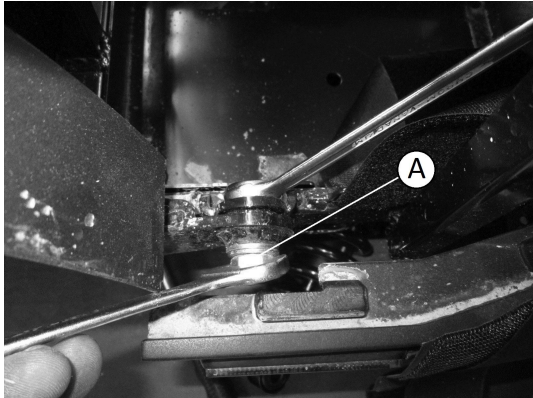

Loosen and remove screw (A) that attaches swing arm to chassis on left and right side of the mobility device.

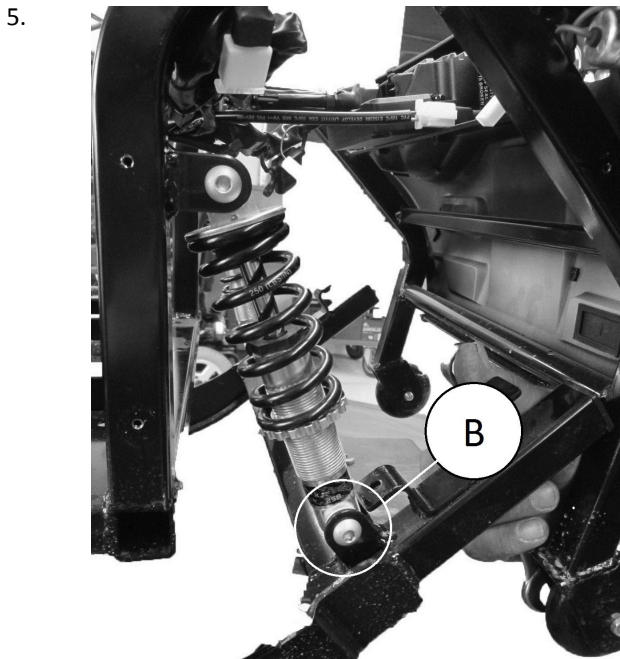

Loosen and remove lower bolt (B) on rear shock absorber on left and right side of mobility device.

-  Be careful not to loose metal bushing (A) in swing arm (B).

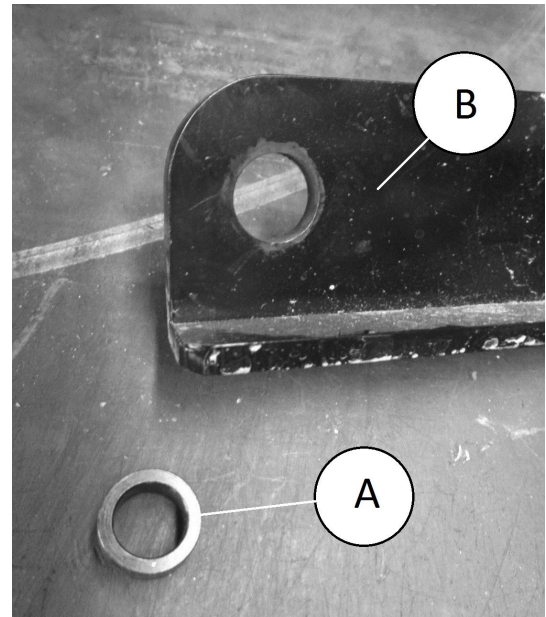

6. Remove and replace swing arm.
- 7.

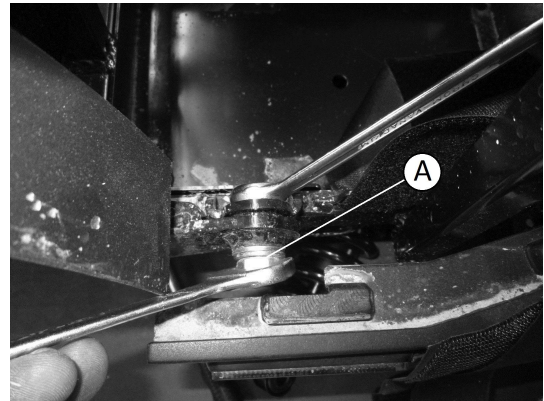

Install parts in reverse order.

-  When reinstalling, tighten screw (A) to 15 Nm.

### 5.8.4 Replacing steering column



**CAUTION!**

**Risk of accident**

Accidental rolling can lead to accidents.

– Secure mobility device against rolling away.



When disassembling, note the position of small parts such as screws and washers. Put small parts down so that they can be reassembled in the right sequence.



- 10 mm wrench
- 13 mm wrench
- 17 mm wrench
- 19 mm wrench
- 32 mm wrench
- Phillips screwdriver
- Supporting wooden block

1. Remove seat.
2. Remove shroud.

3. Disconnect battery cable.
- 4.



Place a supporting wooden block under the front part of the frame so that the front wheel is no longer touching the floor.

**Replacing steering column**

- 1.

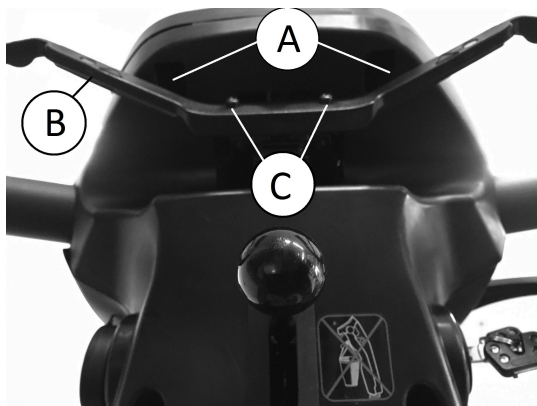

Remove drive lever screws ©.

2. Remove drive lever ©.
3. Loosen and remove screws A on operating console.
4. Remove operating console. See 5.5.1 *Replacing Operating Console, page 15.*
- 5.

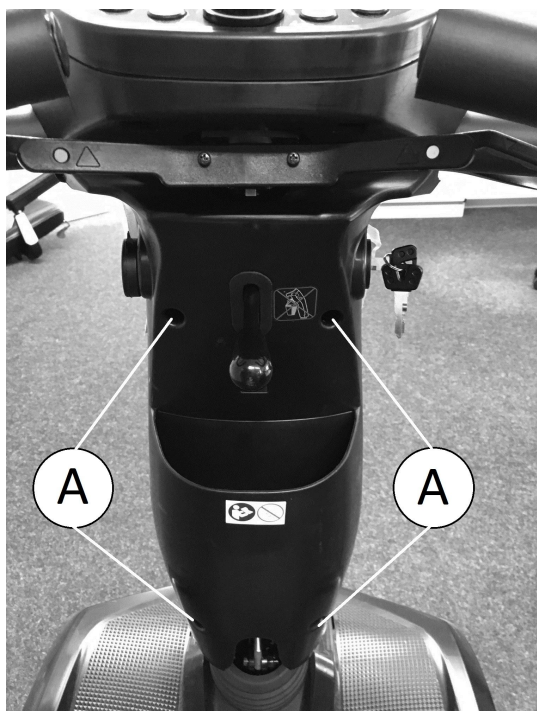

Remove screws A on rear steering column shroud.

6. Remove steering column shroud.

7. Loosen screws on front basket holder.
8. Remove basket holder.
9. Remove spacer bushes.
10. Disconnect cables from wiring harness.
- 11.

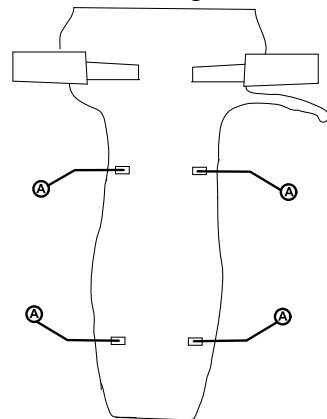

Remove screws A on front steering column shroud.

12. Remove front steering column shroud.
13. Loosen brake cable. See 5.9.1 *Replacing hand brakes, page 27.*
- 14.

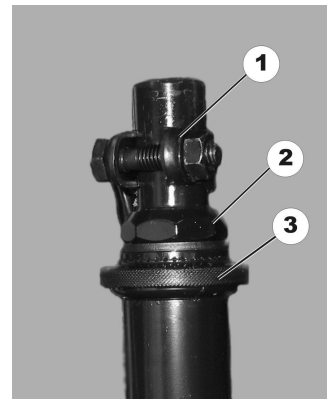

Loosen and remove screw at clamp (1).

15. Loosen and remove fixing bolt for steering column.
16. Pull steering column out upwards.
17. Install parts in reverse order.

Tighten screw (1) to 13 Nm.

18. Apply brake, tighten axle bolts at same time.
19. Test all functions (trial run).

**5.8.5 Replacing Front Wheel Suspension (4-Wheel Version)**



**CAUTION!**  
**Risk of Uncontrolled Movement of Mobility Device**

- Turn off power supply (ON/OFF key).
- Engage drive.
- Before raising mobility device, secure wheels by blocking them with wedges.
- Prevent the mobility device tipping by propping it up on a wooden block which is long and wide enough under the battery case. If the wooden block is too short or too high, the mobility device can still tip.



When removing, take care of small parts such as screws and washers. Put small parts down so that they can be installed in correct sequence.

-  • 10 mm wrench
- 13 mm wrench
- 17 mm wrench
- 19 mm wrench
- 32 mm wrench
- Phillips screwdriver
- Supporting wooden block

**Tightening torques**

Nut	Tightening torque
(A), (C)	10 Nm
(B), (D), (E)	15 Nm



Fig. 5-10

1. Remove seat. See corresponding chapter in user manual.
2. Remove front shroud. See 5.6.2 *Replacing front shroud, page 19*.
3. Unplug battery cable.
4. Place a supporting wooden block under the front part of the frame so that the front wheel is no longer touching the floor.
5. Remove wheels. See 5.8.7 *Repairing tire punctures, page 27*.
- 6.

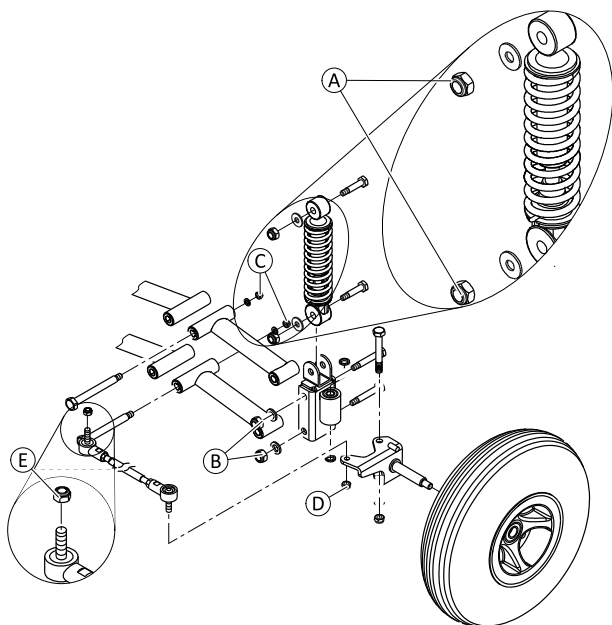



Fig. 5-11

7. Loosen and remove nuts (A).
8. Loosen and remove nuts (D) and (E) that fix two steering links.

9. Loosen and remove nuts (B) on cross members on both sides.
10. Loosen and remove nuts (C) that fix cross members to frame.
11. Replace suspension.
12. Install parts in reverse order. Tighten screws and nuts to prescribed torque. See *Tightening torques, page 26*.
13. Test all functions.

**5.8.6 Replacing and Adjusting Central Rear Shock Absorber**

-  • 17 mm wrench
- 15 mm wrench
- Wooden block
- 45/50 hook wrench
- Vise

 To adjust central rear shock absorber to user weight, Invacare recommends removing central rear shock absorber.

**Removing**

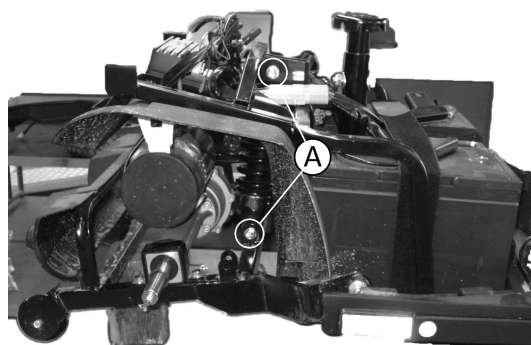

Fig. 5-12

1. Remove wheel (see user manual).
2. Support rear swing arm with wooden block.
3. Loosen and remove screws (A) that hold central shock absorber: First loosen and remove lower screw, then upper screw.
4. Remove central rear shock absorber to the right side.

**Adjusting**

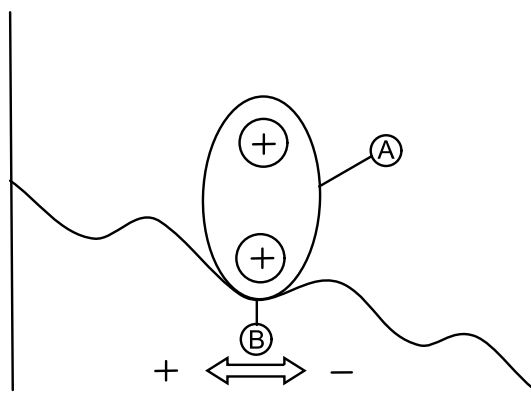



Fig. 5-13

 Presetting of shock absorber is middle setting (B). This setting relates to user weight of 100 kg up to 120 kg. Turning stud (A) clockwise makes spring softer, turning counter-clockwise harder.



1. Place shock absorber in vise.
  2. Preload spring with hook wrench.
-  When preloading, for most users setting the stud **A** to a middle setting **B** is convenient.

### Installing

1. Install parts in reverse order.

## 5.8.7 Repairing tire punctures

### Removing wheel

-  • 17 mm wrench  
• Rubber hammer



1. Raise mobility device and place wooden blocks underneath to support it.
2. Remove wheel locknut (1).
3. Remove wheel by tapping it gently with rubber hammer on the rear face to carefully loosen it from the axle.

 When reinstalling, tighten locknut to 30 Nm.

 **Problems when removing wheel?**  
– It may be necessary to use a special tool. Ask your Invacare provider to help you.

### Repairing flat tire

-  • Inner tube repair set or a new inner tube  
• Talcum powder  
• 12 mm wrench



1. Remove valve cap.
2. Deflate tire by pressing in the center valve pin.

 **CAUTION!**  
**Risk of explosion**  
The wheel explodes if the air pressure has not been released from the wheel before the wheel rim is removed.  
– Always let all the air out of the tire before removing the rim.

3. Loosen and remove 4 screws (1).
4. Remove both wheel rim halves out of tire and remove inner tube.
5. Repair inner tube and refit in wheel, or replace it with new inner tube.

 If the old inner tube has been repaired and is to be used again, and became wet during repair, it is easier to replace it if it is lightly dusted with talcum powder beforehand.

6. Refit wheel rim parts from outside into tire.
7. Pump up tire lightly.
8. Reinsert nuts and bolts which hold the wheel rim together and tighten fully.
9. Make sure that tire is properly located on wheel rim.
10. Inflate tire up to recommended tire pressure.
11. Check to make sure that tire is still located properly on wheel rim.
12. Screw valve cap back on.
13. Locate wheel on drive shaft again.
14. Apply handbrake and hold it there to center brake.
15. Tighten wheel locknut with handbrake applied.



### CAUTION!

**Risk of injury from wheels coming loose**  
If wheels are insufficiently secured during mounting, they can come loose when driving.

- When mounting wheels, tighten bolts with 30 Nm.
- Never use normal nuts instead of self-locking nuts.
- Always use new bolts with an undamaged coating.

## 5.9 Brakes

### 5.9.1 Replacing hand brakes



### CAUTION!

**Risk of accident**

Accidental rolling can lead to accidents.  
– Secure the scooter against rolling away.



When disassembling, note the position of small parts such as screws and washers. Put small parts down so that they can be reassembled in the right sequence.



- 12 mm wrench
- 13 mm wrench
- Philipps screwdriver
- Allen key 5 mm
- Supporting wooden block

1. Remove seat.
2. Remove shroud.
3. Disconnect battery cable.



Place a supporting wooden block under the front part of the frame so that the front wheel is no longer touching the floor.

4. Slacken both brake cables.
5. Disconnect brake cable at affected wheel.
6. Loosen wheel bolt.
7. Pull wheel and brake off shaft.
- 8.
- 9.



Pull brake out of brake drum.

10. Replace brake lining or complete brake.
11. Reassemble wheel and brake.
12. Push wheel and brake onto shaft.
13. Apply brake so that brake shoes can align.
14. Install parts in reverse order.
15. Adjust braking force on wheel using brake lever setting screw.
16. Check braking function while pushing.

### 5.9.2 Replacing brake cable



**CAUTION!**  
**Risk of accident**

Accidental rolling can lead to accidents.  
– Secure mobility device against rolling away.



When disassembling, note position of small parts such as screws and washers. Put small parts down so that they can be reassembled in right sequence.



You do not need to remove wheel to replace brake cable.



- 10 mm wrench
- Phillips screwdriver

1.

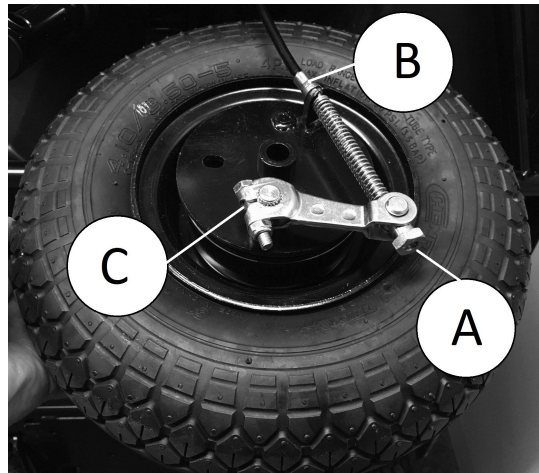

1. Slacken brake cable using setting screw **A**.
2. Disconnect brake cable at wheel **B**.
3. Disconnect brake cable at brake lever on steering column.
4. Route brake cable through shroud.
5. Loosen brake lever screw **C** at wheel.
6. Replace brake cable.
7. Install parts in reverse order.
8. Test braking function while pushing.

### 5.9.3 Replacing steering link/coupling rod



**CAUTION!**  
**Risk of accident**

Accidental rolling can lead to accidents.  
– Secure scooter against rolling away.



When disassembling, note position of small parts such as screws and washers. Put small parts down so that they can be reassembled in right sequence.



- 10 mm wrench
- 12 mm wrench
- 13 mm wrench
- Phillips screwdriver
- Circlip pliers
- Supporting wooden block

1. Remove seat.
2. Remove shroud.
- 3.

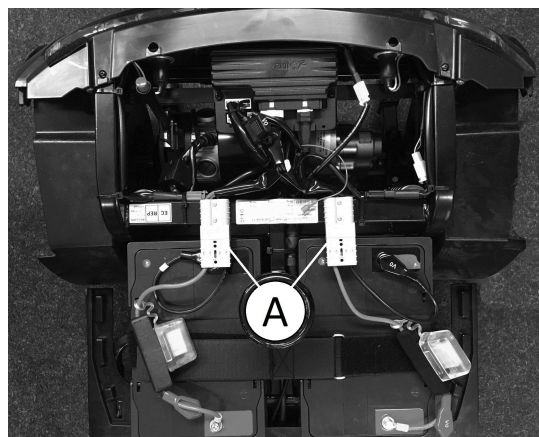

4. Disconnect battery cable **A**.
5. Remove steering column and chassis. See 5.8.4 *Replacing steering column, page 24.*



### Replacing steering link/coupling rod

1.

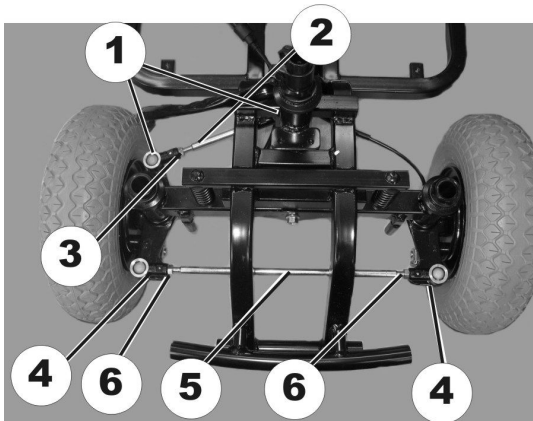

1. Remove circlip (1) on steering link (2).
2. Replace steering link.
3. Adjust length of steering link using setting screws (3).
4. Remove circlip (4) on coupling rod (5).
5. Replace coupling rod.
6. Install parts of steering link and/or coupling rod in reverse order.
7. Test all functions (trial run).

### Adjusting camber

1. Loosen screws (A).
- 2.

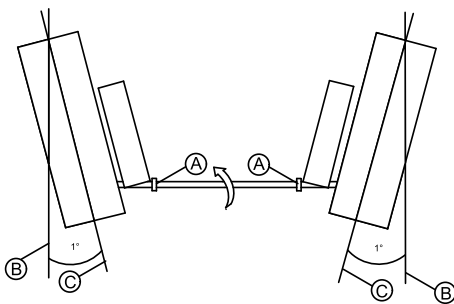

3. Spin steering link up by 0,5 cm. Wheels stand turned inwards by 1° (C) from neutral position (B).
3. Install parts of steering link and/or coupling rod in reverse order.
4. Test all functions (trial run).

### 5.9.4 Replacing curve control device



#### CAUTION! Risk of accident

Accidental rolling can lead to accidents.  
– Secure mobility device against rolling away.



When disassembling, note the position of small parts such as screws and washers. Put small parts down so that they can be reassembled in the right sequence.



- Phillips screwdriver
- 32 mm wrench

1. Remove seat.
2. Remove shroud.

3.

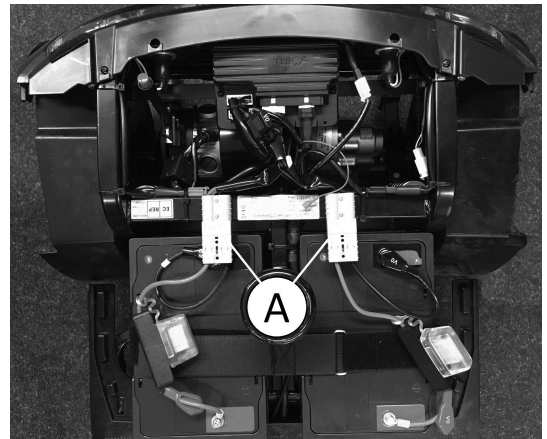

Disconnect battery cable (A).

4.

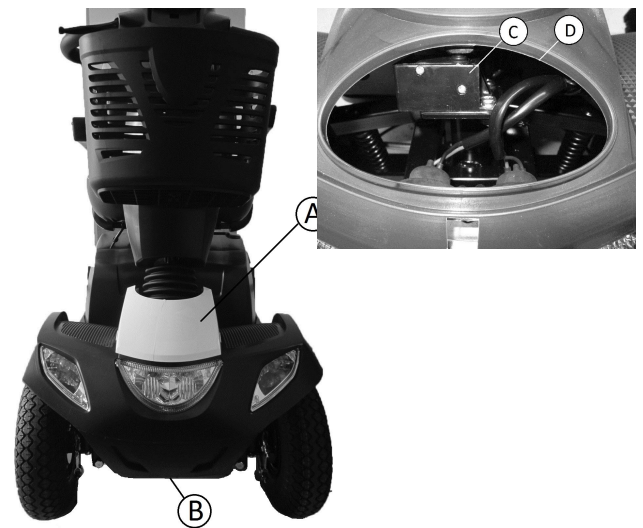

Remove front shroud colored cap (A).

5. You can see curve control device (C) through opening (D).
6. Remove screw (B) that fixes shroud between front wheels.
- 7.

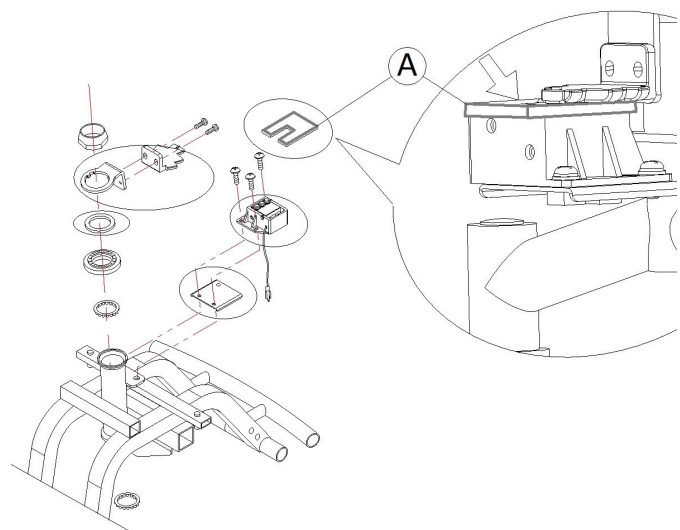

To check position of sensors of curve control device, use measuring gauge (A) supplied in "Bend speed reducer retrofitting kit".

### Replacing sensors (5) without mounting

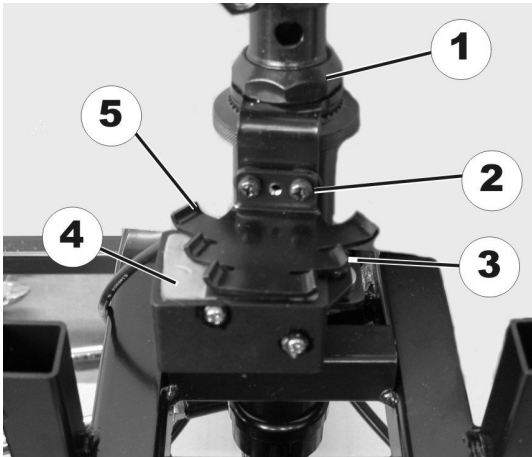

1. Loosen screws (2).
2. Replace sensor.

### Replacing sensors (5) with mounting

1. Loosen fork bolt (1).
2. Replace sensors (5) with mounting.

### Replacing regulating unit (4)

1. Loosen screws.
2. Remove sensor (5).
3. Loosen screws (3).
4. Replace regulating unit (4).

### Adjusting

1. Set steering to straight ahead.
2. Align sensor straight using regulating unit.
3. Take hold of the sensor and tighten the fork screw.

### Check

1. Turn steering completely to right and then left.
2. When steering is turned to its limit, the 3 regulating unit switches should be visible.
3. Install parts in reverse order.
4. Check functions (trial run).

## 5.10 Drive Components

### 5.10.1 Replacing drive unit



**CAUTION!**  
**Risk of accident**

When parking mobility device on antitippers it is no longer slowed by motor brake. Mobility device can roll away out of control.  
– Place mobility device rear frame on a supporting wooden block before you remove wheels.



**CAUTION!**  
**Risk of accident**

Accidental rolling can lead to accidents.  
– Secure mobility device against rolling away.



When disassembling, note the position of small parts such as screws and washers. Put small parts down so that they can be reassembled in the right sequence.



The plugs on the power module cannot be wrongly connected because all plugs have a different size and only fit in one socket.



- 10 mm wrench
- 17 mm wrench
- Oblique pliers
- Rubber hammer
- Phillips screwdriver
- Supporting wooden block
- 5 mm Allen key
- Thread locking adhesive (for example Loctite 243)

1. Secure mobility device against rolling away.
2. Place supporting wooden block under the frame at battery holder height.
3. Remove seat.
4. Remove shroud.
- 5.

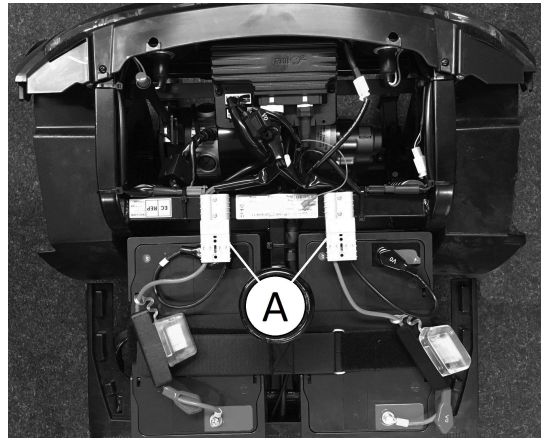

Disconnect battery cable (A).

6. Unscrew rear wheel fixing bolts.
7. Remove rear wheels.
8. Cut cable ties.
- 9.

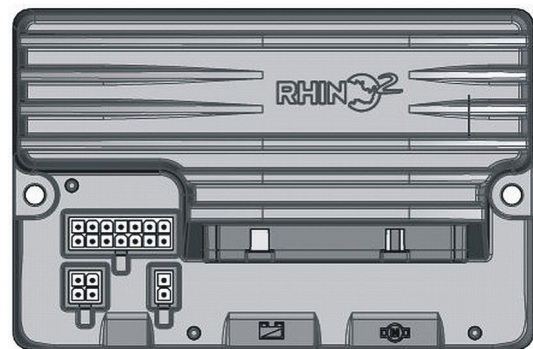

Disconnect plugs from power module.

- Disconnect motor plug.
- Disconnect plug for electromagnetic brake.
- Disconnect speedometer plug.

10.

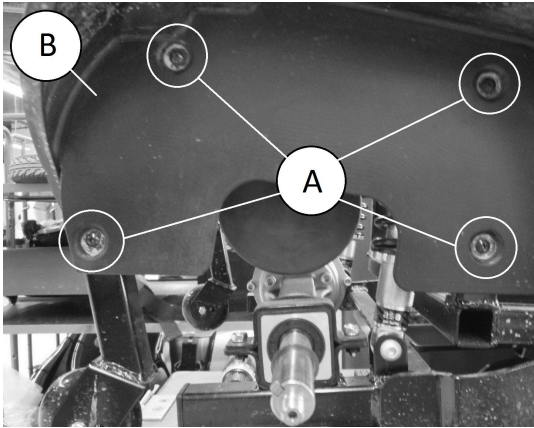

Remove screws Ⓐ on mud guard.

11. Remove mud guard Ⓑ.

12.

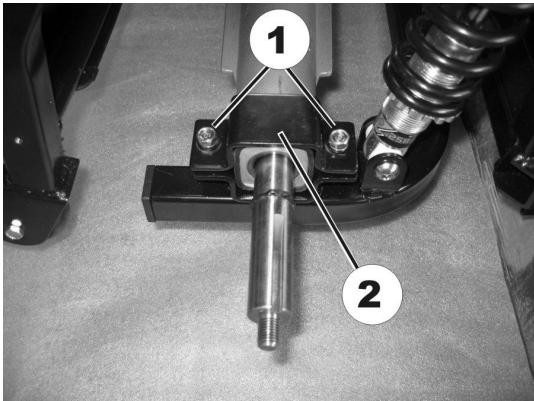

Remove screws (1) on drive holder (2).

13. Remove drive holder (2).

14.

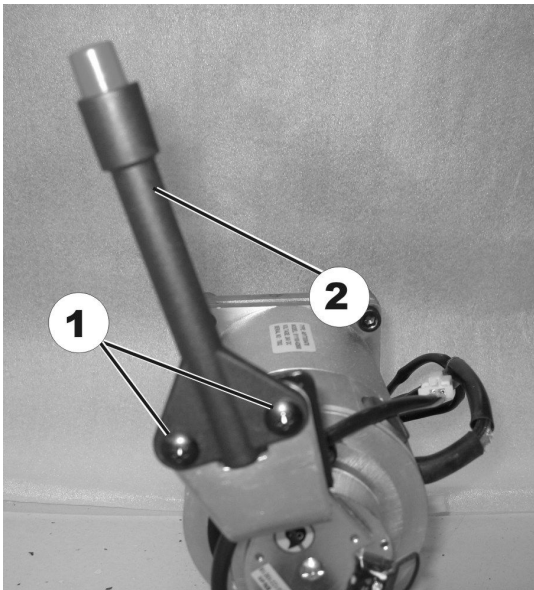

Remove screws (1) on disengaging lever (2).

15. Remove disengaging lever (2).

16. Place supporting wooden block under swing arm.

**Replacing drive motor**

1.

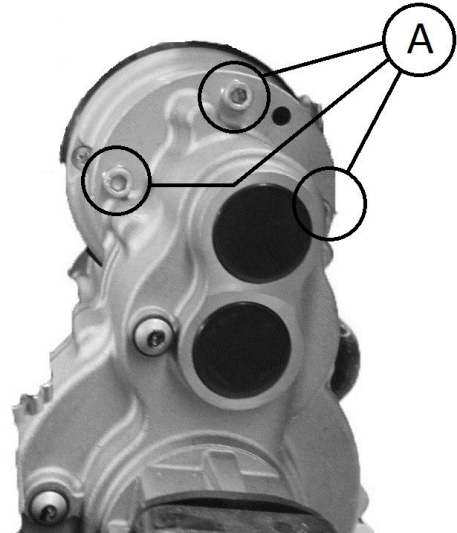

Loosen three Allen screws Ⓐ.

2. Lift motor out of holder and take it out of the frames to the side.

3. Replace motor.

**Replacing drive unit**

1.

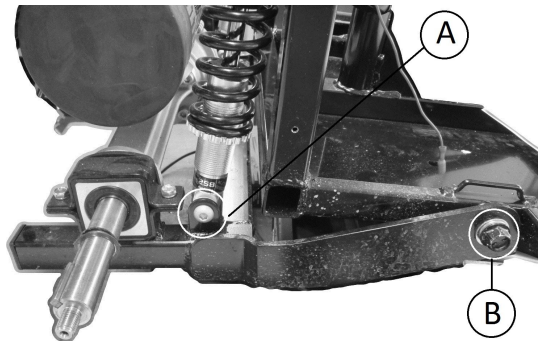

Loosen and remove screw Ⓑ on swing arm. For replacing swing arm, see 5.8.3 *Replacing swing arm*, page 24 .

2. Loosen and remove lower bolt Ⓐ on spring.

3. Lift drive unit out of holder and take it out of the frames to the side.

4. Replace drive unit.

**Installation**

1. Install parts in reverse order.

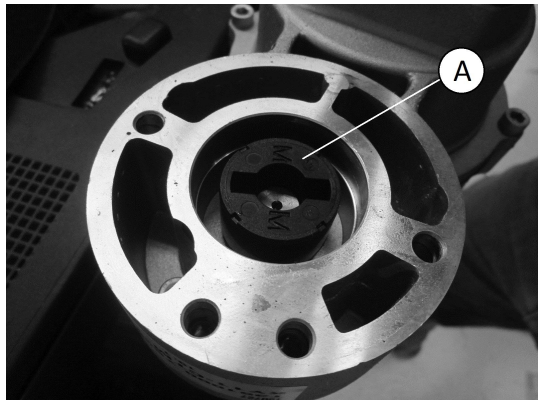

**CAUTION!**

**Reduced function when clutch is mounted incorrectly**

– Make sure to mount clutch Ⓐ with inscription “M” facing motor.





**CAUTION!**  
**No breaking efficiency without feather key**  
 – Make sure to mount feather key (B) on motor shaft (A) when reassembling.

2. Tighten screw (B) on swing arm to 15 Nm.
3. Check all functions (trial run).

### 5.10.2 Replacing carbon brushes



 Always replace all the carbon brushes on both motors.

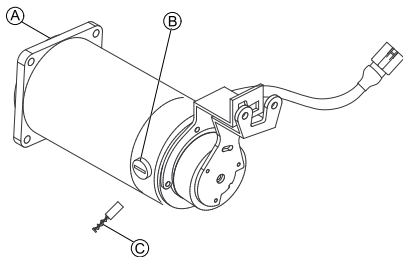

- 5 mm Allen key
- 6 mm Allen key
- 10 mm socket wrench
- 19 mm socket wrench
- Blade screwdriver
- Long wooden blocks, min. 14 x 14 x 30 cm

#### Removing carbon brushes



1. Switch off mobility device.
2. Remove drive wheels.
3. Disengage motor (A) by setting the engaging lever to "Push".
4. Loosen and remove all four plastic caps (B).  
 Note the fixing position and location of the carbon brushes.  
 Used carbon brushes need to be refitted exactly in the same position from which they were taken in order to guarantee optimum contact to the collector.
5. Make a marking on the motor and the carbon brushes in order to guarantee correct installation.
6. Remove carbon brushes completely from mounting (C).
7. Check carbon brush and spring for level of wear, broken components or discolouration.

#### Installing carbon brushes

1. Depending on condition of brush and spring: - either install brushes in exactly the same position from which they were taken or - fit new brushes.
2. Install plastic caps and tighten them firmly.

3. Install drive wheels..



The following procedure is necessary to run carbon brushes in after replacement and thus guarantee maximum performance.



**CAUTION!**

**Risk of accidents**

Injuries to workers, damage to surroundings and mobility device.  
 – Do not leave mobility device unattended during the following procedure.  
 – Secure area.

4. Lift mobility device up on one side and get a second person to place a wooden block around 14 cm high underneath it so that the drive wheel is suspended freely.
5. Repeat on other side of mobility device.
6. Allow motors to run for an hour in forward direction.
7. Allow motors to cool down for 30 minutes.
8. Allow motors to run for an hour in reverse direction.
9. Lift mobility device off wooden blocks.

### 5.11 Seat

#### 5.11.1 Replacing seat suspension/spring



**CAUTION!**

**Risk of accident**

Accidental rolling can lead to accidents.  
 – Secure the scooter against rolling away.



When disassembling, note the position of small parts such as screws and washers. Put small parts down so that they can be reassembled in the right sequence.

The following seat support tubes lengths are available for the seat suspension:

- 508.5 mm
- 533.5 mm
- 558.5 mm



- 17 mm wrench (2x)

1. Secure scooter against rolling away.
2. Remove seat.
- 3.

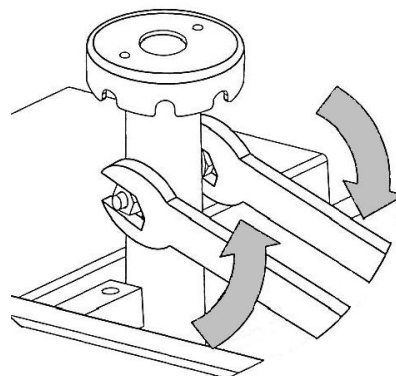

Loosen securing bolt of seat support tube.

4.

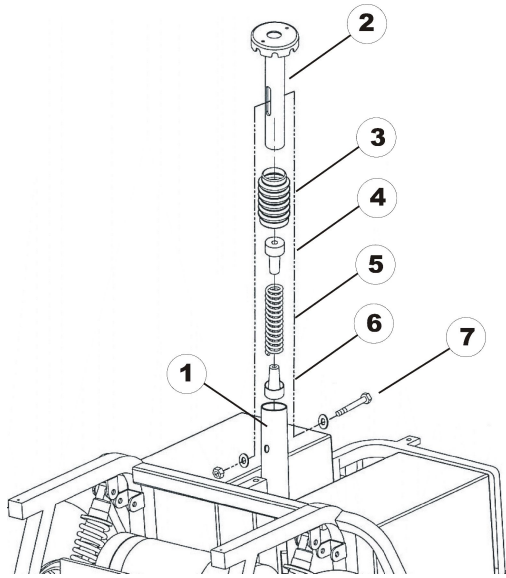

Remove bolt (7), nut and washers.

5. Remove seat support tube (2) from receptacle tube (1).
6. Remove bellows (3) including spring (5) and plastic end pieces (4 and 6).
7. Fit plastic end pieces (4 and 6) to new spring.
8. Grease spring generously. The spring should be covered completely.
9. Assemble bellows (3).
10. Install bellows (3) including the spring (5) and the plastic end pieces (4 and 6).
11. Insert seat support tube (2) into receptacle tube (1) and press down gently.
12. Reposition bolt (7), nut and washers.

13.

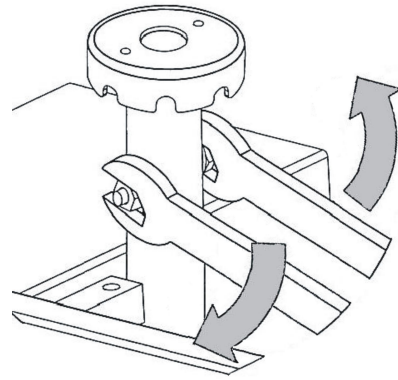

Firmly tighten securing bolt of seat support tube.

14. Reposition seat.

### 5.11.2 Replacing seat support tube



- 17 mm wrench (2x)

1. Remove seat.
2. Remove shroud. See "Removing shroud".
- 3.



Remove securing bolt, nut and washers of seat support tube.

4. Replace seat support tube.
5. Adjust seat height.
6. Reinsert securing bolt, nut and washers and tighten.

---

## 6 Accessories

---

### 6.1 Accessories List

- Mirror (right or left)
- Safety vest
- Warning triangle
- Solid tires (without rim), 13 inch grey or black
- Seat lifter kit, electrical, 12 cm
- Seat suspensions
- Front bumper
- Rear bumper
- Personal key
- Crutch & Cane holder
- Lockable storage box, front
- Lockable storage box, rear, incl. clutch holder bracket
- Rear basket
- Backrest bag
- Hour counter
- Rollator holder incl. crutch holder
- Windscreen
- Seat belt
- Oxygen bottle holder
- Can holder
- Off-board charger kit
- Covers: Storage cover (Full scooter cover), Seat Cover (Rain & Dirt protection)



The mounting instructions for accessories are available at your Invacare provider or directly from Invacare.



## Invacare representatives/distributors

### Australia:

Invacare Australia Pty. Ltd.  
1 Lenton Place, North Rocks NSW  
2151  
Australia  
Phone: 1800 460 460  
Fax: 1800 814 367  
orders@invacare.com.au  
www.invacare.com.au

### United Kingdom:

Invacare Limited  
Pencoed Technology Park, Pencoed  
Bridgend CF35 5AQ  
Tel: (44) (0) 1656 776 222  
Fax: (44) (0) 1656 776 220  
uk@invacare.com  
www.invacare.co.uk

### Canada:

Invacare Canada L.P.  
570 Matheson Blvd East, Unit 8  
CDN Mississauga, On. L4Z 4G4  
Phone: (905) 890 8300  
Toll Free: 800.668.5324  
www.invacare.ca

### Eastern Europe, Middle East & CIS:

Invacare EU Export  
Kleiststraße 49  
D-32457 Porta Westfalica / Germany  
Tel: (49) (0)57 31 754 540  
Fax: (49) (0)57 31 754 541  
webinfo-eu-export@invacare.com  
www.invacare-eu-export.com

### Ireland:

Invacare Ireland Ltd,  
Unit 5 Seatown Business Campus  
Seatown Road, Swords, County Dublin  
Tel : (353) 1 810 7084  
Fax: (353) 1 810 7085  
ireland@invacare.com  
www.invacare.ie

### New Zealand:

Invacare New Zealand Ltd  
4 Westfield Place, Mt Wellington 1060  
New Zealand  
Phone: 0800 468 222  
Fax: 0800 807 788  
sales@invacare.co.nz  
www.invacare.co.nz



### European representative:

EMERGO EUROPE  
Prinsessegracht 20  
2514 AP, The Hague  
The Netherlands



### Manufacturer:

CHIEN TI ENTERPRISE CO. LTD.  
No. 13, Lane 227, Fu Ying Road  
Hsin Chuang, Taipei, Taiwan  
R.O.C.

