

---

# Invacare® ISA™

ISA™ COMPACT, ISA™ STANDARD, ISA™ PLUS, ISA™ XPLUS

## en Mobile Patient Lift User Manual

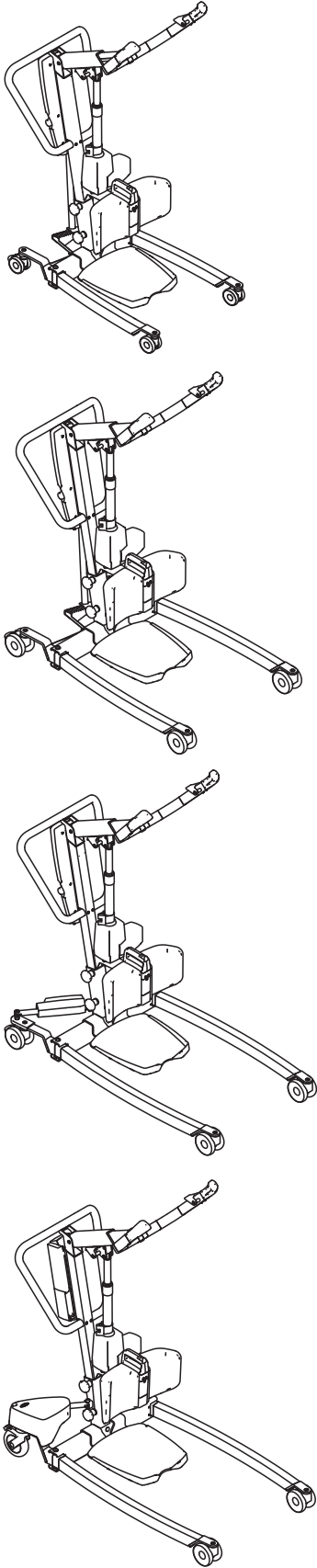

---

This manual **MUST** be given to the user of the product.  
**BEFORE** using this product, this manual **MUST** be read and  
saved for future reference.



**Yes, you can.®**

# Contents

|  |           |
|--|-----------|
| <b>1 General</b>   | <b>3</b>  |
| 1.1 Introduction   | 3         |
| 1.1.1 Symbols in this Document   | 3         |
| 1.2 Service Life   | 3         |
| 1.2.1 Additional information   | 3         |
| 1.3 Limitation of Liability  | 3         |
| 1.4 Warranty Information   | 3         |
| 1.5 Compliance   | 3         |
| 1.5.1 Product-specific standards   | 3         |
| <b>2 Safety</b>  | <b>4</b>  |
| 2.1 General safety information   | 4         |
| 2.1.1 Pinch points   | 5         |
| 2.2 Safety Information on Accessories                                      | 5         |
| 2.3 Safety information on electromagnetic interference                     | 5         |
| 2.4 Labels and symbols on the product                                      | 5         |
| 2.4.1 Label Location   | 5         |
| 2.4.2 Identification label   | 6         |
| 2.4.3 Other Labels and Symbols   | 6         |
| <b>3 Product Overview</b>  | <b>8</b>  |
| 3.1 Intended use   | 8         |
| 3.2 Main parts of the lift   | 8         |
| 3.3 Accessories and Options  | 9         |
| <b>4 Setup</b>   | <b>10</b> |
| 4.1 General safety information   | 10        |
| 4.2 Scope of delivery  | 10        |
| 4.3 Installing the mast to the base  | 10        |
| 4.4 Installing the foot plate  | 11        |
| 4.5 Installing the leg band  | 11        |
| 4.6 Installing the leg support   | 11        |
| 4.7 Installing the lever for manual leg spreader                           | 11        |
| 4.8 Resetting the service counter  | 12        |
| <b>5 Usage</b>   | <b>13</b> |
| 5.1 General safety information   | 13        |
| 5.2 Locking/Unlocking the Rear Castors                                     | 13        |
| 5.3 Raising/Lowering an Electric Lift                                      | 13        |
| 5.4 Closing/Opening Legs   | 13        |
| 5.4.1 Closing/Opening Electric Legs  | 13        |
| 5.4.2 Closing/Opening legs manually  | 13        |
| 5.5 Adjusting the lifting arm to patient body height                       | 13        |
| 5.6 Adjusting the height of the leg support                                | 14        |
| 5.7 Using the leg band   | 14        |
| 5.8 Emergency Functions  | 15        |
| 5.8.1 Performing an emergency stop   | 15        |
| 5.8.2 Activating an emergency lowering (CBJ Home control unit)             | 15        |
| 5.8.3 Activating an emergency lowering (CBJ Care, CBJ1, CBJ2 control unit) | 15        |
| 5.8.4 Activating an emergency lifting (CBJ Care, CBJ1 control unit)        | 15        |
| 5.8.5 Activating a mechanical emergency lowering                           | 15        |
| 5.9 Charging the battery   | 16        |
| 5.9.1 CBJ Home control unit  | 16        |
| 5.9.2 CBJ Care, CBJ1, CBJ2 control unit                                    | 16        |
| 5.9.3 Optional hand control  | 17        |
| 5.9.4 Optional battery charger   | 17        |
| <b>6 Patient Transfer</b>  | <b>19</b> |
| 6.1 General safety information   | 19        |
| 6.2 Attaching the sling to the lift  | 20        |
| 6.3 Transferring a patient   | 21        |
| <b>7 Transportation and Storage</b>  | <b>22</b> |
| 7.1 General information  | 22        |
| 7.2 Disassembling the lift   | 22        |
| <b>8 Maintenance</b>   | <b>23</b> |
| 8.1 General maintenance information  | 23        |
| 8.2 Daily inspections  | 23        |
| 8.2.1 Daily Inspection Checklist   | 23        |
| 8.3 Cleaning and Disinfection  | 23        |
| 8.3.1 General Safety Information   | 23        |
| 8.3.2 Cleaning Intervals   | 23        |
| 8.3.3 Cleaning instructions  | 23        |
| 8.3.4 Disinfection Instructions  | 24        |
| 8.4 Service Interval   | 24        |
| <b>9 After Use</b>   | <b>25</b> |
| 9.1 Disposal   | 25        |
| 9.2 Reconditioning   | 25        |
| <b>10 Troubleshooting</b>  | <b>26</b> |
| 10.1 Identifying faults and possible solutions                             | 26        |
| <b>11 Technical Data</b>   | <b>28</b> |
| 11.1 Maximum safe working load   | 28        |
| 11.2 Dimensions and Weights  | 28        |
| 11.3 Electrical System   | 29        |
| 11.4 Environmental conditions  | 30        |
| 11.5 Materials   | 30        |
| 11.6 Operating forces of controls  | 30        |
| <b>12 Electromagnetic Compatibility</b>                                    | <b>31</b> |
| 12.1 General EMC information   | 31        |
| 12.2 Electromagnetic emission  | 31        |
| 12.3 Electromagnetic Immunity  | 31        |
| 12.4 EMC test specifications   | 32        |

# 1 General

## 1.1 Introduction

This user manual contains important information about the handling of the product. To ensure safety when using the product, read the user manual carefully and follow the safety instructions.

Only use this product if you have read and understood this manual. Seek additional advice from a healthcare professional who is familiar with your medical condition and clarify any questions regarding the correct use and necessary adjustment with the healthcare professional.

Note that there may be sections in this document, which are not relevant to your product, since this document applies to all available models (on the date of printing). If not otherwise stated, each section in this document refers to all models of the product.

The models and configurations available in your country can be found in the country-specific sales documents.

Invacare reserves the right to alter product specifications without further notice.

Before reading this document, make sure you have the latest version. You find the latest version as a PDF on the Invacare website.

If you find that the font size in the printed document is difficult to read, you can download the PDF version from the website. The PDF can then be scaled on screen to a font size that is more comfortable for you.

For more information about the product, for example product safety notices and product recalls, contact your Invacare distributor. See addresses at the end of this document.

In case of a serious incident with the product, you should inform the manufacturer and the competent authority in your country.

### 1.1.1 Symbols in this Document

Symbols and signal words are used in this document and apply to hazards or unsafe practices which could result in personal injury or property damage. See the information below for definitions of the signal words.



#### **WARNING!**

Indicates a hazardous situation that could result in serious injury or death if it is not avoided.



#### **CAUTION!**

Indicates a hazardous situation that could result in minor or slight injury if it is not avoided.



#### **NOTICE!**

Indicates a hazardous situation that could result in damage to property if it is not avoided.



#### **Tips and Recommendations**

Gives useful tips, recommendations, and information for efficient, trouble-free use.

#### **Other Symbols**

(Not applicable for all manuals)



#### **UK Responsible Person**

Indicates if a product is not manufactured in the UK.



#### **Triman**

Indicates recycling and sorting rules (only relevant for France).

## 1.2 Service Life

The expected service life of this product is eight years when used daily and in accordance with the safety instructions, maintenance intervals and correct use, stated in this manual. The effective service life can vary according to frequency and intensity of use.

### 1.2.1 Additional information

The expected service life is based on an estimated average of 4 lifting cycles per day.

## 1.3 Limitation of Liability

Invacare accepts no liability for damage arising from:

- Non-compliance with the user manual
- Incorrect use
- Natural wear and tear
- Incorrect assembly or set-up by the purchaser or a third party
- Technical modifications
- Unauthorised modifications and/or use of unsuitable spare parts

## 1.4 Warranty Information

We provide a manufacturer's warranty for the product in accordance with our General Terms and Conditions of Business in the respective countries.

Warranty claims can only be made through the provider from whom the product was obtained.

## 1.5 Compliance

Quality is fundamental to the company's operation, working within the disciplines of ISO 13485.

This product features the CE mark, in compliance with the Medical Device Regulation 2017/745 Class I.

This product features the UKCA mark, in compliance with Part II UK MDR 2002 (as amended) Class I.

We are continuously working towards ensuring that the company's impact on the environment, locally and globally, is reduced to a minimum.

We only use REACH compliant materials and components.

We comply with the current environmental legislations WEEE and RoHS.

### 1.5.1 Product-specific standards

The product has been tested and conforms to ISO 10535 (Hoists for the transfer of persons with disabilities) and all related standards.

For further information about local standards and regulations, contact your local Invacare representative. See addresses at the end of this document.

## 2 Safety

### 2.1 General safety information

This section of the manual contains general safety information about your product. For specific safety information, refer to the appropriate section of the manual and procedures within that section.



**WARNING!**

**Risk of injury or damage**

- Do not use this product or any available optional equipment without first completely reading and understanding these instructions and any additional instructional material such as user manuals or instruction sheets supplied with this product or optional equipment. If you are unable to understand the warnings, cautions or instructions, contact a healthcare professional, Invacare provider or qualified technician before attempting to use this product.
- Do not make any unauthorized alterations or modifications to the product.



**WARNING!**

**The maximum safe working load must not be exceeded**

- Do not exceed the maximum safe working load of this product or used accessories like slings, spreader bars etc. See documentation or the labelling for the stated maximum safe working load.
- The component with the lowest load limit determines the maximum safe working load of the entire system.



**WARNING!**

**Risk of injury or damage**

Improper use of this product may cause injury or damage.

- Do not attempt any transfer without approval of the patient's healthcare professional.
- Read the instructions in this user manual and observe trained personnel performing transfer procedures. Then practice transfers under supervision and with a capable person acting as a patient.
- Special care must be taken with people with disabilities who cannot cooperate while being transferred.
- Do not use the lift as a transport device. It is intended to transfer an individual from one resting surface to another.



**WARNING!**

**Risk of injury or damage**

Inappropriate handling of cables can cause electrical shock and product failure.

- Do not kink, shear or otherwise damage the cables of the product.
- Make sure that no cables are jammed or damaged when the product is used.
- Make sure the wiring is correct and connections are proper.
- Do not use unauthorized equipment.



**WARNING!**

**Risk of injury or damage**

Excessive moisture will damage the product and may cause electrical shock.

- The patient lift can be used in a bath or shower area but must NOT be used under the shower. The patient must be transferred to a shower chair or use other means for showering.
- If the patient lift is used in a moisture environment, ensure that the patient lift is wiped clean of any moisture after use.
- Do not plug or unplug the power cable in a moisture environment or with wet hands.
- Do not store the product in a damp area or damp condition.
- Periodically inspect all components of the product for signs of corrosion or damage. Replace parts that are corroded or damaged.
- See *11.4 Environmental conditions, page 33*



**WARNING!**

**Risk of injury or damage**

Ignition sources can cause burns or fire.

- Patient transfer must be performed with a safety space between the lift and possible ignition sources (heater, stove, fireplace, etc.)
- The patient and assistants must not smoke during transfer.
- The sling must not be placed over heat sources (heater, stove, fireplace, etc.)



**WARNING!**

**Risk of injury or damage**

To avoid injury or damage when operating the product:

- Close supervision is necessary when the product is used near children or pets.
- Do not let children play with the product.



**CAUTION!**

**Risk of injury or damage**

The product can get hot when exposed to sunlight or other heat sources.

- Do not expose the product to direct sunlight for prolonged periods.
- Keep the product away from heat sources.



**NOTICE!**

Accumulation of lint, dust and other dirt can impair the product.

- Keep the product clean.

### 2.1.1 Pinch points

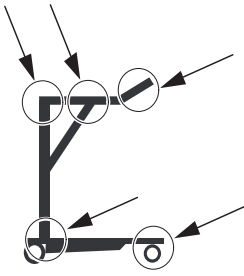

**WARNING!**  
**Risk of Injury**

Pinch points are present in several locations on the lift and fingers could be pinched.

- Always keep hands and fingers clean of moving parts.

### 2.2 Safety Information on Accessories



**WARNING!**  
**Risk of Injury**

Non-original or incorrect accessories may affect the function and safety of this product.

- Due to regional differences, refer to your local Invacare website or catalogue for available accessories or contact your Invacare provider.
- See the manual delivered with the accessory for further information and instructions.
- Use only original accessories for the product in use. Under certain circumstances, the use of slings from other manufacturers is possible. See additional information in this section.



**CAUTION!**  
**Compatibility of Slings with Attachment System**

Invacare uses a common attachment system based on hooks and loops. Loops on the slings are attached to hooks on spreader bars (coat hanger style). Therefore, suitable slings of other manufacturers can be used on this lift as well.

- Use only slings with loop attachments that are suitable for spreader bars (coat hanger style) with hooks.
- Do not use slings designed for "Keyhole or Clip Attachment Systems" or "Tilting Frame Systems".

To select the appropriate sling, a risk assessment must be performed by a healthcare professional. The risk assessment must consider:

- The patient's weight, size, physical ability and medical condition.
- The type of transfer and the environment.
- The compatibility to the other lifting equipment used.

## 2.3 Safety information on electromagnetic interference



**WARNING!**  
**Risk of malfunction due to electromagnetic interference**

Electromagnetic interference between this product and other electrical equipment can occur and disturb the electrical adjustment functions of this product. To prevent, reduce or eliminate such electromagnetic interference:

- Only use original cables, accessories and spare parts, to not increase electromagnetic emission or reduce electromagnetic immunity of this product.
- Do not use portable radio frequency (RF) communications equipment closer than 30 cm to any part of this product (including cables).
- Do not use this product near active high-frequency surgical equipment and the RF shielded room of a system for magnetic resonance imaging, where the intensity of electromagnetic disturbances is high.
- If disturbances occur, increase the distance between this product and the other equipment or switch it off.
- Refer to the detailed information and follow the guidance in chapter 12 *Electromagnetic Compatibility*, page 31



**WARNING!**  
**Risk of malfunction**

Electromagnetic interference may cause improper operation.

- Do not use this product adjacent to or stacked with other electrical equipment. If such use is necessary this product and the other equipment must be closely observed to verify that they are operating normally.

## 2.4 Labels and symbols on the product

### 2.4.1 Label Location

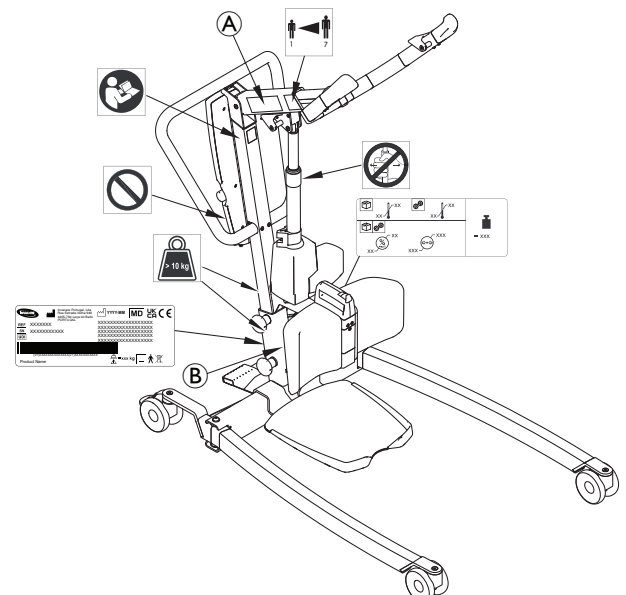

|   |   |
|---|---|
| A | Name and safe working load of lift – text depending on model          |
| B | Safe working load of lift – text depending on model (fixed mast only) |

For more information on the labels see the following information.

### 2.4.2 Identification label



The identification label contains the main product information, including technical data.

| Symbols |                             |
|---------|-----------------------------|
|         | Medical device              |
|         | European Conformity         |
|         | UK Conformity Assessed      |
|         | Manufacturer                |
|         | Date of manufacture         |
|         | Max. safe working load      |
|         | Universal Device Identifier |
|         | Serial number               |
|         | Reference number            |
|         | Class II equipment          |
|         | Type B applied part         |
|         | WEEE conform                |

For more information about technical data, see *11 Technical Data, page 28*

### 2.4.3 Other Labels and Symbols



Read the user manual before using this product and follow all instructions for safety and use.



Do not apply any side forces to the actuator (e.g. by using it as a push bar) as this might result in damage and malfunction.





Do not remove this label and manipulate the underlying screw as this might impair the safety of the product.

The warranty of the product is voided if this label is removed or broken.

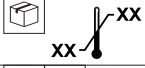
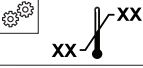

Individual part weighs more than 10 kg.

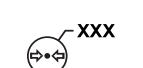
|  |   |   |
|--|---|---|
|  |  |  |
|  |  |   |

|  |  |
|--|--|
|  | Total weight of the product with the maximum safe working load applied |
|  | Temperature limit  |
|  | Humidity limitation  |
|  | Atmospheric pressure limitation  |
|  | Transport and storage conditions                                       |
|  | Operation conditions   |

Abbreviations for technical data:

- I<sub>in</sub> = Incoming Current
- U<sub>in</sub> = Incoming Voltage
- Int. = Intermittence
- AC = Alternating Current
- Max = maximum
- min = minute

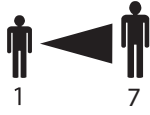

Lifting arm adjustment in correlation to the body height of the patient.

See *5.5 Adjusting the lifting arm to patient body height*, page 13



## 3 Product Overview

### 3.1 Intended use

The stand assist patient lift is a battery-powered transfer device and is intended to transfer and position an individual from one seating surface to another. For example:

- Between the bed and a wheelchair
- To and from the toilet
- Rehabilitation, assisting a patient from a seated position to a standing position

The maximum safe working load is stated in *11 Technical Data, page 28*

The stand assist patient lift is designed to be used indoors on a level surface, in hospitals, nursing facilities and domestic areas. The stand assist patient lift can be turned (rotated) in place for transfers with limited floor space.

A healthcare professional or private person who has received proper training is the intended operator of this product.

### Intended Users

The intended user is partially immobile weight-bearing patients.

### Indications

The stand assist lift is intended to transfer and position partially immobile weight-bearing patients.

### Contraindications

The stand assist lift is contraindicated for patients who:

- are not cooperative;
- are not able to understand and follow instructions;
- do not have head and neck control;
- do not have reasonable trunk stability.

Some slings designed for the stand assist lift are contraindicated for patients who cannot support the majority of their weight. Refer to the sling user manual for more information.

### 3.2 Main parts of the lift

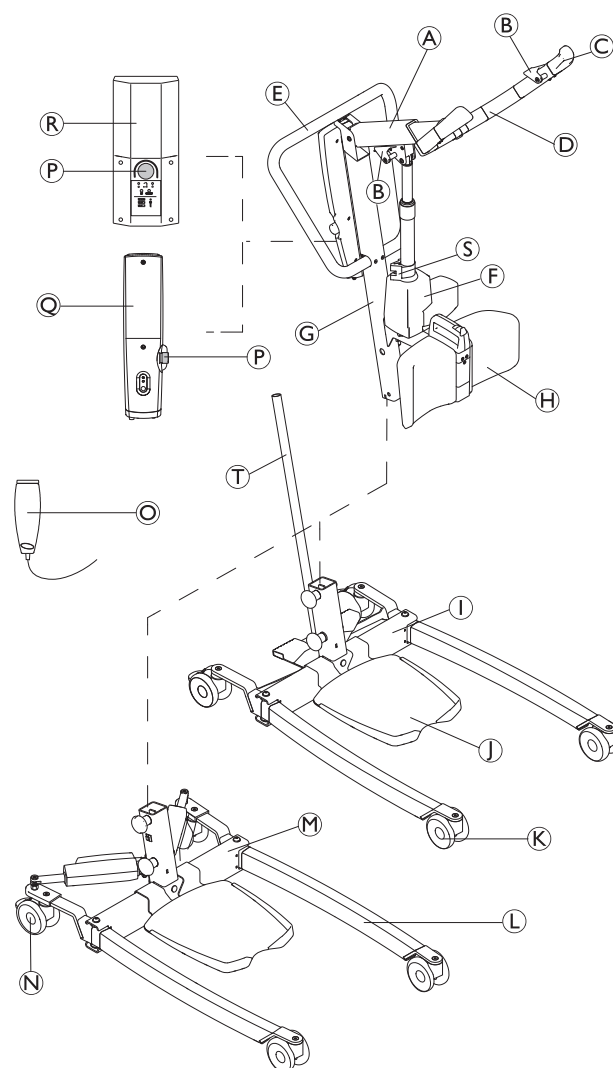

|     |   |
|-----|---|
| (A) | Boom  |
| (B) | Hook for sling  |
| (C) | Hand grip   |
| (D) | Lifting arm   |
| (E) | Push bar  |
| (F) | Lifting actuator  |
| (G) | Mast  |
| (H) | Leg support (fixed or swiveling)  |
| (I) | Base with foot pedal for manual leg spreader                                      |
| (J) | Foot plate (high, low or inclined)  |
| (K) | Front Castors   |
| (L) | Leg   |
| (M) | Base with actuators for electrical leg spreader — with or without actuator covers |
| (N) | Rear castors with brake   |
| (O) | Hand control  |
| (P) | Emergency Stop  |
| (Q) | CBJ Home control unit with integrated battery                                     |



|   |   |
|---|---|
| ® | CBJ Care, CBJ1 or CBJ2 control unit with detachable battery |
| Ⓢ | Mechanical emergency lowering                               |
| Ⓣ | Lever for manual leg spreader                               |

### 3.3 Accessories and Options

 Due to regional differences, refer to your local Invacare website or catalog for details about available accessories or contact your Invacare provider.

- Lever for manual leg spreader
- Protective covers for legs
- Leg band
- Wall charger for a detachable battery
- Extra battery
- Extra foot plate (high, low or inclined)

Sling models with loop attachments, suitable for hooks as attachment points:

- Invacare® Stand Assist sling (Europe) / Invacare® Standup sling (APAC): 2–point attachment with back support only.
- Invacare® Transfer Stand Assist sling: 4–point attachment with back and leg support.

## 4 Setup

### 4.1 General safety information



**WARNING!**

- Check all parts for shipping damage before use, see 8.2 Daily inspections, page 23.
- In case of damage, do not use the equipment. Contact your Invacare provider for further instructions.



**WARNING!**

**Risk of Injury**

- Improper assembly may cause injury or damage.
- Use only Invacare parts in the assembly of this patient lift.
  - After each assembly, check that all fittings are properly tightened and all parts have the correct function
  - Do not overtighten the mounting hardware. This may damage the mounting brackets.



There are no tools required to assemble the patient lift. If there are any issues or questions during assembly, contact your Invacare provider.

### 4.2 Scope of delivery

The items included in your package depend on the models and configurations available in your country. See 1.1 Introduction, page 3

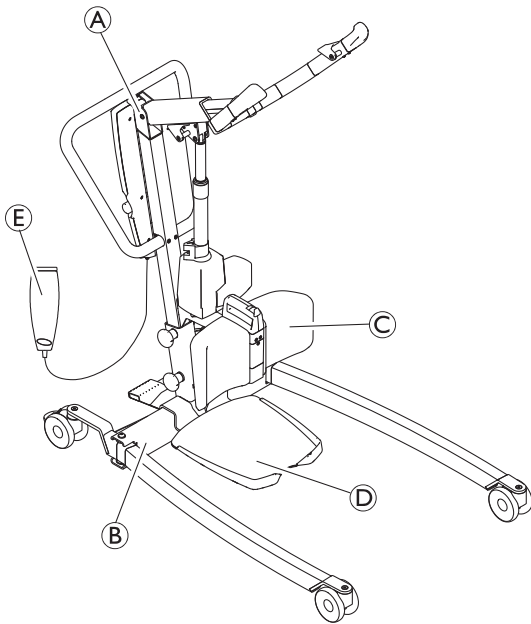

|     |  |
|-----|--|
| (A) | Mast / boom assembly (1 piece) — incl. control unit and actuator |
| (B) | Base with or without actuators (1 piece)                         |
| (C) | Leg support  |
| (D) | Foot plate   |
| (E) | Hand control (1 piece)   |
|     | Mains cable (1 piece)  |
|     | User Manual (1 piece)  |

|  |   |
|--|---|
|  | Battery (1 or 2 pieces)* – CBJ Care, CBJ1 and CBJ2 only |
|  | Lever for manual leg spreader (1 piece)*                |
|  | Leg band (1 piece)*                                     |
|  | Sling (1 piece)*  |

\* Depends on model and/ or configuration



If the lift is delivered with a sling, refer to the user manual of the sling for use, application, maintenance and washing instructions.

### 4.3 Installing the mast to the base



**WARNING!**

**Risk of injury or damage**

- The maximum safe working load stated on the boom and on the base must be the same.
- Always compare the maximum safe working load values stated on the base and on the boom.

1.

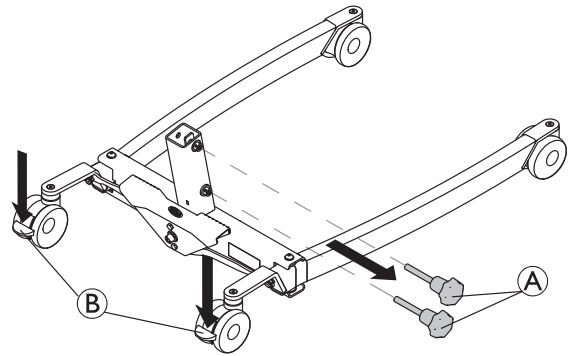

Lock both rear castors (B) and rotate the hand screws anti-clockwise (A) to remove them from the base

2.

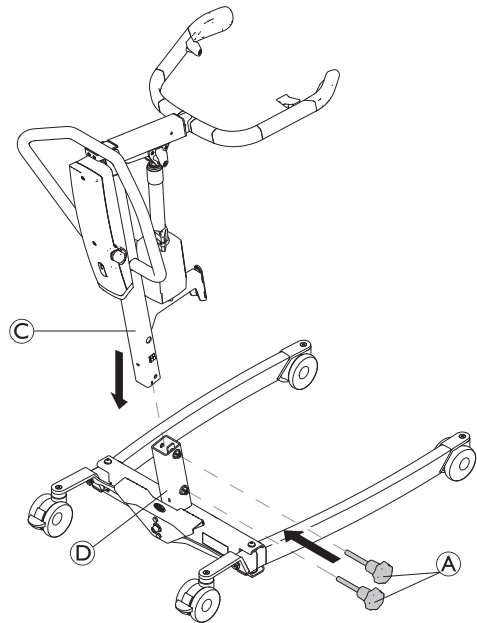

With the boom pointing in forward direction, lower the mast (C) into the support of base (D) and reinstall the hand screws (A) to fix the mast (C) to the base.

## 4.4 Installing the foot plate

1.

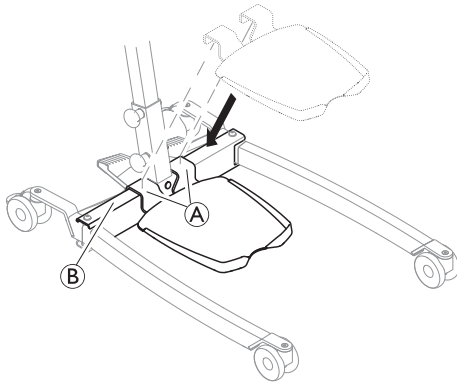

Lower the foot plate onto the base until the brackets **A** are fully seated on tube **B**.

## 4.5 Installing the leg band

(optional)

1.

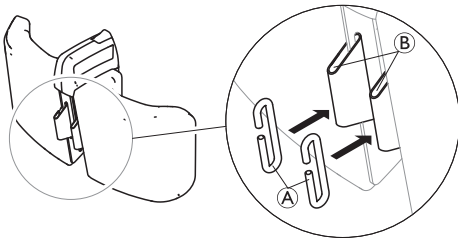

Thread the two hooks **A** into lugs **B** on the back side of the leg support.

2.

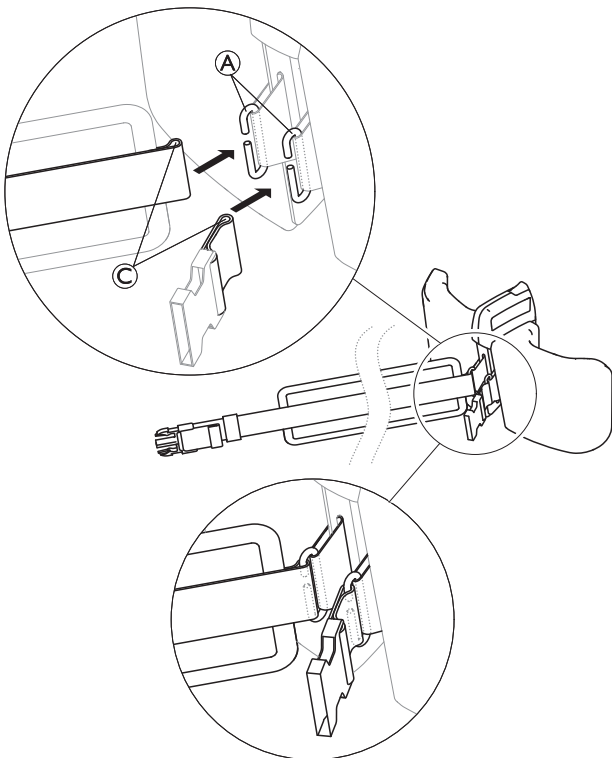

Thread the loops **C** of the two leg band parts into the hooks **A**.

## 4.6 Installing the leg support

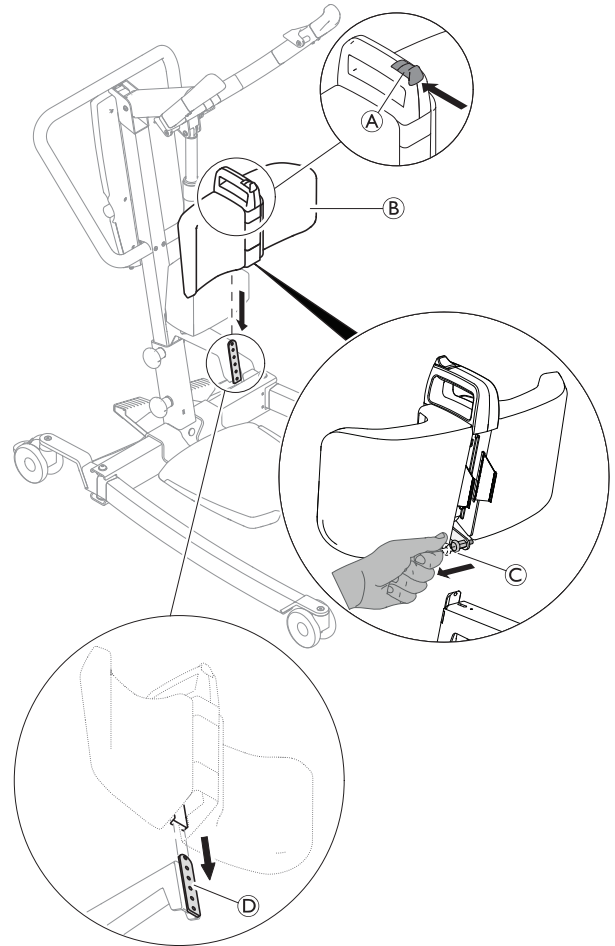

1. Push and hold the button **A** on the leg support **B**.
2. Pull and hold the spring loaded plunger pin **C** on the back of the leg support **B**.
3. Slide the guide bar on the back of the leg support **B** onto its mounting plate **D** on the mast.

## 4.7 Installing the lever for manual leg spreader

 2 x 13 mm wrench

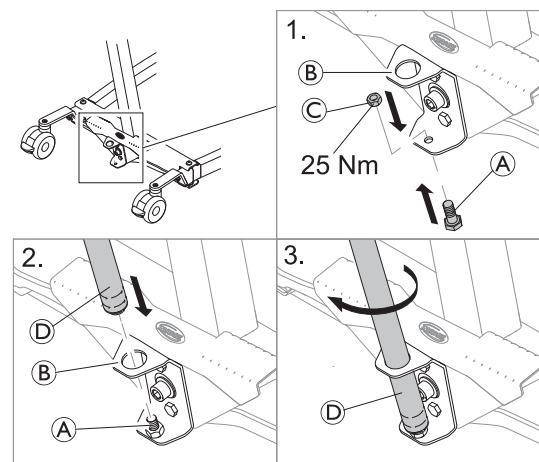

1. Insert the bolt **A** from below into the lower hole of the bracket **B** and fix it with the nut **C**.
2. Insert the threaded end of lever **D** into the upper hole of bracket **B** onto the fixed bolt **A**.
3. Turn the lever **D** clockwise to screw it onto the bolt.

## 4.8 Resetting the service counter

(CBJ Care control unit only)



### NOTICE!

If the service light is flashing yellow during daily usage or after a reassembly, the lift requires service.  
— Contact your Invacare provider for service.

After the initial assembly of the lift, the service counter needs to be reset before using the lift.

To perform the initial reset of the service counter:

1. Locate the hand control.
2. Press and hold the **UP** button and the **DOWN** button at the same time for five seconds.
3. A sound is heard once the service counter is reset.

## 5 Usage

### 5.1 General safety information



#### WARNING!

##### Risk of injury or damage

Before using the lift with a patient, refer to the following safety information and instructions:

- 2 Safety, page 4
- 6 Patient Transfer, page 19

### 5.2 Locking/Unlocking the Rear Castors



#### WARNING!

##### Risk of Injury or Damage

The lift could tip and endanger the patient and assistants.

- Invacare recommends that the rear castors be left unlocked during lifting procedures to allow the patient lift to stabilize itself when the patient is initially lifted from a chair, bed or any stationary object.
- Invacare recommends locking the rear castors of the lift only when positioning or removing the sling from around the patient.

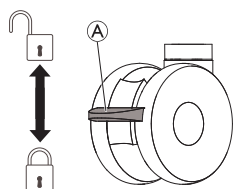

- To lock the castor, push down pedal (A) with the foot.
- To unlock the castor, push up pedal (A) with the foot.

### 5.3 Raising/Lowering an Electric Lift

The hand control is used to raise or lower the lift.



#### WARNING!

##### Risk of Injury or Damage

Damage to parts of the lift (hand control, castors, etc.) caused by impact with walls or other stationary objects may cause damage to the product and lead to injury.

- DO NOT raise the boom manually.
- ALWAYS use the hand control to raise the boom.

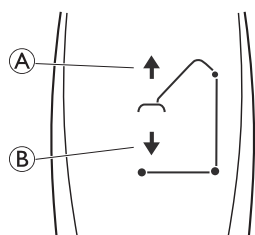

1. To raise the lift — Press and hold the UP (A) button to raise the boom and the patient.
2. To lower the lift — Press and hold the DOWN (B) button to lower the boom and the patient.

ⓘ Release the button to stop raising or lowering the lift.

### 5.4 Closing/Opening Legs



#### WARNING!

##### Risk of Injury

The lift could tip and endanger the patient and assistants.

- The legs of the lift must be in the maximum open position for optimum stability and safety. If it is necessary to close the legs of the lift to manoeuvre the lift under a bed, close the legs of the lift only as long as it takes to position the lift over the patient and lift the patient off the surface of the bed. When the legs of the lift are no longer under the bed, return the legs of the lift to the maximum open position.

#### 5.4.1 Closing/Opening Electric Legs

The hand control is used to open or close the legs of the base.

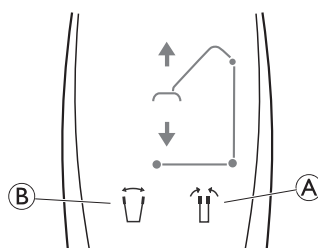

1. To close the legs, press and hold the legs closed button (A).
2. To open the legs, press and hold the legs open button (B).

ⓘ The legs will stop moving when the button is released.

#### 5.4.2 Closing/Opening legs manually

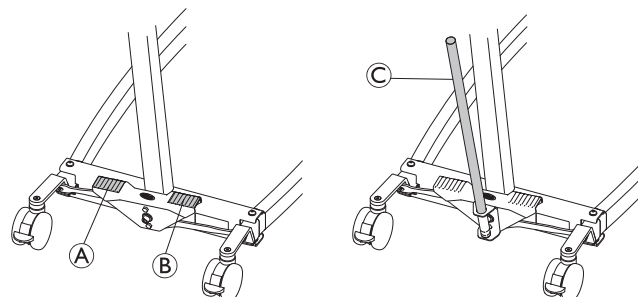

The manual leg spreader is operated by two pedals (A and B) or by the lever (C).

1. To open the legs, press the right pedal (B) with a foot.
2. To close the legs, press the left pedal (A) with a foot.

With the lever:

1. To open the legs, pull the lever (C) to the right.
2. To close the legs, push the lever (C) to the left.

### 5.5 Adjusting the lifting arm to patient body height



#### CAUTION!

##### Risk of injury or damage

A wrong boom position may cause the lifting arm to suddenly slide in or out when released.

- Always adjust the lifting arm when unloaded and with the boom in horizontal position.

The main adjustment criteria is the patients body height, but the correct setting also depends on other factors such as length of the sling loops, patient condition and preference.

The following guidelines are based on average values and deviations can and do occur:

- Position 1 (fully shortened): patient height from about 140 cm and taller.
- Position 4: patient height from about 170 cm and taller.
- Position 7 (fully extended): patient height up to about 200 cm.

**! NOTICE!**  
An individual trial fitting is strongly recommended to determine a correct and safe setting for each patient.

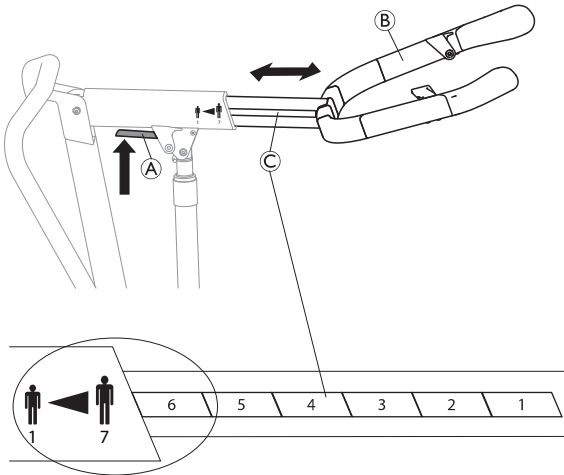

- Push and hold the red lever **A** on the boom upwards.
- Adjust the length of the lifting arm **B** to one of the nine available positions indicated on the scale **C**, by placing the desired position field before the edge of the boom.
- Release the lever **A** and slightly move the lifting arm **B** back and forth until an audible click is heard and it is locked into position.

## 5.6 Adjusting the height of the leg support

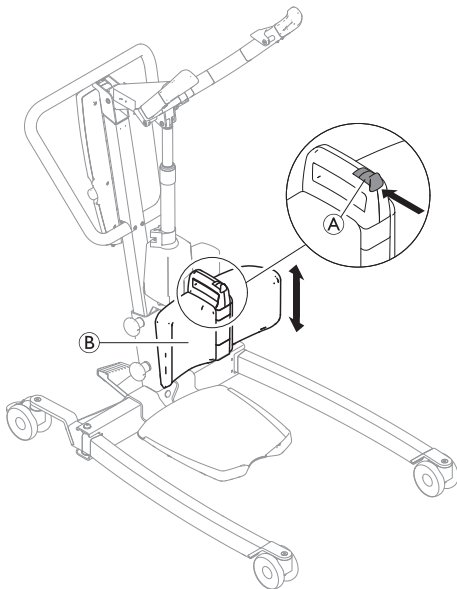

1. Push and hold the button **A** on the leg support **B**.
2. Slide the leg support **B** up or down.
3. When the desired height is reached, release the button **A** and slightly move the leg support **B** up or down until an audible click is heard and the leg support **B** is locked into one of the 6 available height positions.

## 5.7 Using the leg band

1.

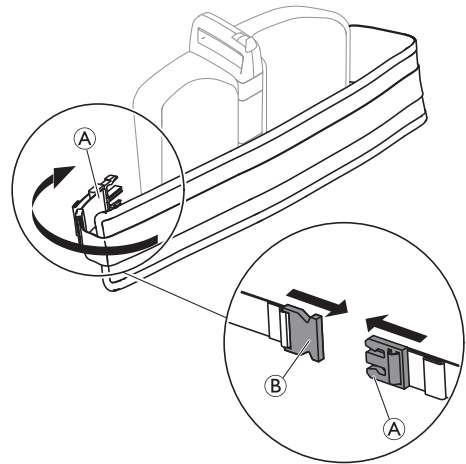

To apply the leg band, wrap the long padded part around the leg support and the patient's lower legs and push the catch **A** into the buckle clasp **B** on the back side of the leg support.

2.

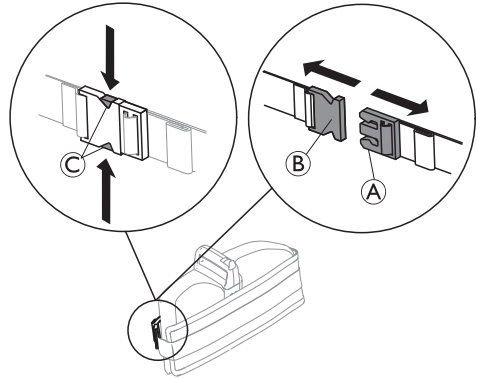

To open, press the release mechanism **C** and pull the catch **A** out of the buckle clasp **B**.

3.

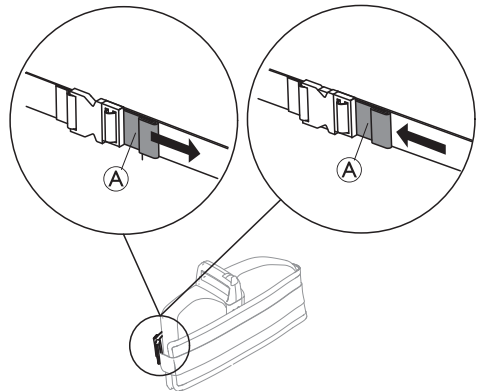

To adjust the length of the leg band, either pull on the lug **A** to shorten or push the lug **A** towards the buckle to lengthen.

**i** When there is no patient in the lift, wrap the leg band around the leg support, close and shorten it to tighten.

## 5.8 Emergency Functions

### 5.8.1 Performing an emergency stop

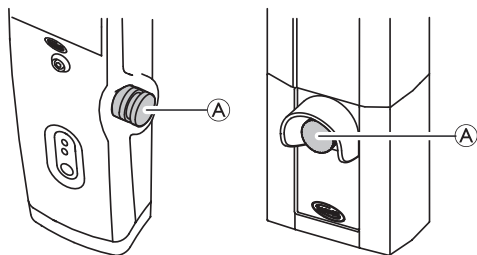

1. Press the red emergency button **A** on the control unit to stop the boom and patient from raising or lowering.
2. To reset, rotate the emergency button clockwise.

### 5.8.2 Activating an emergency lowering (CBJ Home control unit)

If the hand control fails, the boom can be lowered by using the circular switch for emergency release.

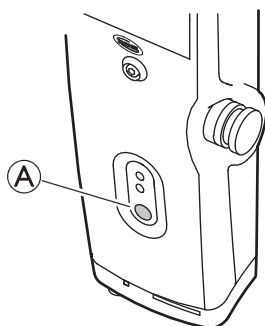

1. Lower the boom by pressing and holding button **A** at the front of the control unit.
2. Stop lowering the boom by releasing the button.

### 5.8.3 Activating an emergency lowering (CBJ Care, CBJ1, CBJ2 control unit)

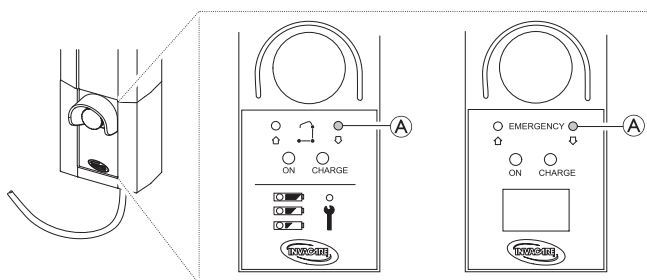

If the hand control fails, the boom can be lowered by using the circular switch for emergency release. Use a sharp object, such as a pencil to press the button.

1. Lower the boom by pressing and holding button **A** at the front of the control unit.
2. Stop lowering the boom by releasing the button.

### 5.8.4 Activating an emergency lifting (CBJ Care, CBJ1 control unit)

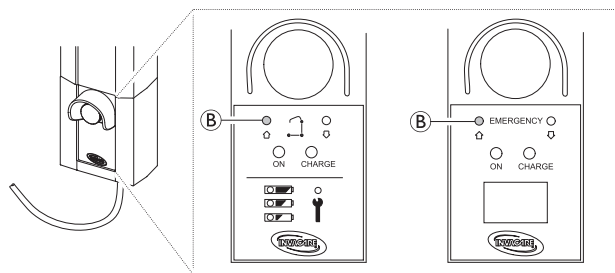

If the hand control fails, the boom can be raised by using the circular switch for emergency lifting. Use a sharp object, such as a pencil to press the button.

1. Raise the boom by pressing and holding button **B** at the front of the control unit.
2. Stop raising the boom by releasing the button.

### 5.8.5 Activating a mechanical emergency lowering

If the emergency lowering on the control unit is not working, a mechanical emergency lowering is available as a back-up. This may happen in case of partial or total power failure, or if the battery runs down during use.



#### WARNING!

#### Risk of Injury or Damage

Repeated mechanical emergency lowering leads to a high increase of the lowering speed.

- Only use the mechanical emergency lowering as a back-up when the emergency lowering on the control unit is not working.
- Do not use the mechanical emergency lowering repeatedly in close succession.
- Always lower the patient onto a supporting surface like a bed or a chair.
- After a mechanical emergency lowering was required, the lift must be checked to resolve the malfunction of the control unit.

1. Locate the red emergency grip **A** at the bottom of the actuator piston.
2. Slowly pull up the red emergency grip **A** and hold it in position when a safe lowering speed is reached.
3. If no lowering occurs with a fully pulled emergency grip **A**, push down on the boom at the same time.

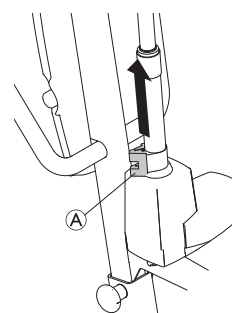

The effective lowering speed is depending on the patient weight. If the speed is too low or too high, it can be adapted to the patient weight. Adjusting the lowering speed:

1. Locate the screw in the bottom hole of the red emergency grip **A**.
2. Turn the screw counter-clockwise to increase the speed.
3. Turn the screw clockwise to decrease the speed.



## 5.9 Charging the battery

### ! NOTICE!

- Make sure the emergency stop is not activated while charging the battery.
- Make sure that charging takes place in a room with good air ventilation.
- Electrical functions are not working when the lift is connected to power supply.
- Do not attempt to use the lift if the battery housing is damaged.
- Replace a damaged battery housing before further use.
- Do not move the lift without unplugging from the power outlet.

It is recommended to charge the battery daily to ensure optimal use of the lift and prolong the life of the battery. Furthermore, it is recommended to charge the battery before first use.

### 5.9.1 CBJ Home control unit

The control unit is equipped with a sound signal. A beep indicates that the battery has low capacity, but lowering the patient is still possible. It is recommended to charge the batteries as soon as the sound signal is heard.

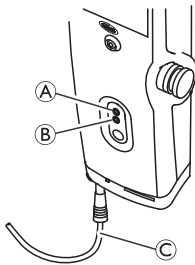

1. Plug the power cord © into a power outlet.

**i** The battery will charge in approximately 4 hours. The charger stops automatically when the batteries are fully charged. The upper yellow diode ① will flash during charging, and switch to continuous light when fully charged. The lower green diode ② will light continuously while the control unit is connected to the mains, and lights up when any button on the hand control is pressed or when the electric emergency lowering is activated.

2. Disconnect the power cord from the power outlet after the battery has been fully charged.

3. Store the power cord around the two cable management supports ⑤:

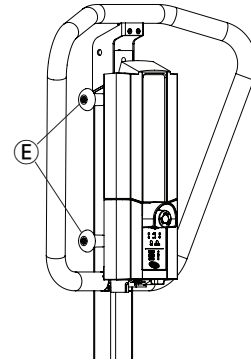

### 5.9.2 CBJ Care, CBJ1, CBJ2 control unit

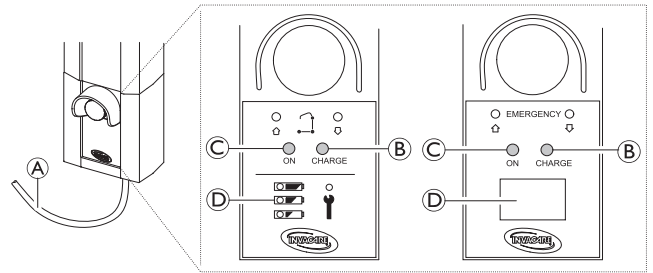

The control unit is equipped with a sound signal. A beep indicates that the battery has low capacity, but lowering the patient is still possible. It is recommended to charge the batteries as soon as the sound signal is heard.

1. Plug the power cord ① into a power outlet.

**i** The battery will charge in approximately 4 hours. The charger stops automatically when the batteries are fully charged. The right yellow diode ② will light continuously during charging, and switch off when fully charged. The left green diode ③ will light continuously while the control unit is connected to the mains.

2. Disconnect the power cord ① from the power outlet after the battery has been fully charged.
3. Store the power cord around the two cable management supports ⑤:

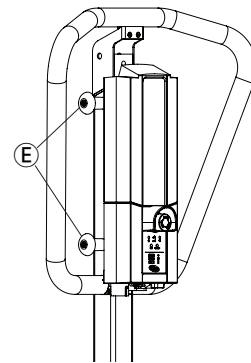



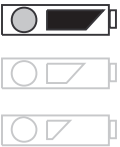
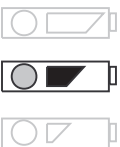
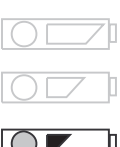
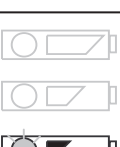

## Battery Indicator

The control unit may be equipped with a battery indicator , indicating the remaining battery capacity.

### CBJ Care



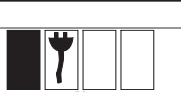

| Battery Indicator Type   | Battery State             | Description   |
|--|---------------------------|---|
|   | Full Charge               | The battery is OK — no need for charging (100–50%). The top LED is GREEN.   |
|   | Partial Charge            | The battery needs to be charged (50–25%). The middle LED is YELLOW.   |
|   | Low Charge                | The battery needs to be charged (Less than 25%). Acoustic signal when a button is pressed. The bottom LED is YELLOW.      |
|  | Low Charge (LED flashing) | The battery needs to be charged. Some of the functionality of the lift is lost and it is only possible to lower the boom. |

### CBJ1 and CBJ2 with LCD

| Battery Indicator Type   | Battery State        | Description   |
|--|----------------------|---|
|  | Full Charge (100%)   | The battery is OK — no need for charging (100%).  |
|  | Partial Charge (75%) | The battery is OK — no need for charging (75%).   |
|  | Partial Charge (50%) | The battery needs to be charged (50%).  |
|  | Low Charge (25%)     | The battery needs to be charged (25%). Acoustic signal when a button is pressed.  |
|  | Low Charge (0%)      | The battery needs to be charged. Some of the functionality of the lift is lost and it is only possible to lower the boom. |

## 5.9.3 Optional hand control

For CBJ Care an optional hand control with battery indicator is available.

| Battery Indicator Type  | Battery State             | Description   |
|---|---------------------------|---|
|  | Full Charge               | The battery is OK — no need for charging (100–50%). The right LED is GREEN.   |
|  | Partial Charge            | The battery needs to be charged (50–25%). The middle LED is YELLOW.   |
|  | Low Charge                | The battery needs to be charged (Less than 25%). Acoustic signal when a button is pressed. The left LED is YELLOW.        |
|  | Low Charge (LED flashing) | The battery needs to be charged. Some of the functionality of the lift is lost and it is only possible to lower the boom. |

## 5.9.4 Optional battery charger

(for control units with detachable battery only)

 The procedure of removing or installing the battery is the same for the control unit and the charger.

### Removing the battery

1.

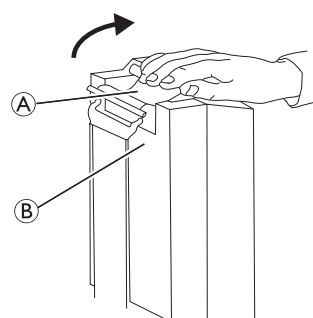

2.

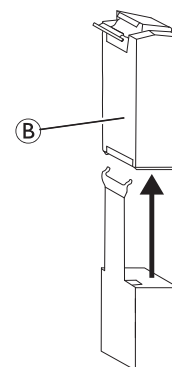

- Lift up on the handle **A** on the back of the battery **B**.
- Lift the battery up and out away from the control unit or charger.

## Installing the battery



### CAUTION!

Installing the battery improperly may cause injury or damage.

- Make sure there is an audible click when installing the battery on the control unit or charger to confirm proper installation.

1. Place the battery **B** on the control unit or charger as shown and make sure there is an audible click.

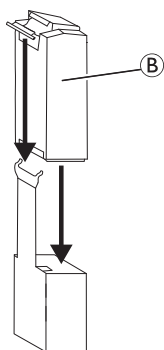

When the battery is placed on the charger, the charge LED will illuminate. When charging is complete, charge LED will switch off.

A battery needing to be fully recharged will take approximately four hours.

## 6 Patient Transfer

### 6.1 General safety information



#### WARNING!

##### Risk of Injury or Damage

Improper use of this product may cause injury or damage.

- Before transferring to a stationary object (wheelchair, bed, commode or other surface) check that the weight capacity can withstand the patient's weight.
- If applicable the brakes of the stationary object (wheelchair, bed etc.) must be applied before lowering the patient onto or lifting the patient off.
- When using the lift in conjunction with beds or wheelchairs, be aware of the position of the lift in relationship to those other devices so that the lift does not become entangled.
- Before positioning the legs of the patient lift under a bed, make sure that the area is clear of any obstructions.



#### WARNING!

##### Risk of Injury or Damage

Improper use of this product may cause injury or damage.

- Use the push bars on the mast at all times to push or pull the lift.
- Avoid using the lift on an incline. Invacare recommends that the product only be used on a flat surface.
- During transfer, with the patient suspended in a sling attached to the lift, DO NOT roll lift over uneven surfaces that could cause the lift to tip over.
- During transfer, with the patient suspended in a sling keep the legs at the maximum open position for optimum stability. If it becomes necessary to move through a narrow passage, close the legs only as long as required and return to maximum open position as soon as possible.



#### WARNING!

##### Risk of Injury or Damage

Damage to parts of the lift (hand control, castors, etc.) caused by impact with the floor, walls or other stationary objects may cause damage to the product and lead to injury.

- DO NOT allow parts of the lift to impact the floor, walls or other stationary objects.
- ALWAYS store the hand control properly when not in use.



#### WARNING!

##### Risk of Injury

Injury to the patient and/or assistant may occur:

- Always be aware of the position of the lifting arm and the patient.
- Always be aware of the position of the foot plate, especially the patient's position on the foot plate.
- Before positioning the legs of the lift around the patient, make sure that the patient's feet are out of the way of the foot plate.
- Always ensure that the foot plate and/or patient's feet are dry before performing a transfer.



#### WARNING!

##### Risk of Entrapment or Strangulation

The hand control cord can cause injury if improperly positioned and secured.

- ALWAYS be aware of the location of the hand control cord in relation to the patient and caregivers.
- DO NOT allow the hand control cord to become entangled around the patient and caregivers.
- The hand control must be secured properly. ALWAYS store the hand control properly when not in use.



#### WARNING!

##### Risk of Entrapment or Strangulation

Items in the patient's surroundings can cause entrapment strangulation during lifting. To avoid entrapment or strangulation:

- Before lifting, check that the patient is completely free of his/her surroundings.



#### WARNING!

##### Risk of Entrapment

There is a risk of entrapment between the spreader bar hooks and the sling.

- Use caution when lifting.
- NEVER put hands or fingers on or near the hooks when lifting.
- Ensure the patient's hands and fingers are away from the hooks before lifting.



#### WARNING!

##### Risk of injury

Injury to the patient and/or assistant may occur:

- If lifting arm and/or leg support is not adjusted correctly to the patient height.
- If the lifting arm adjustment is not locked, damaged or with worn parts.



#### NOTICE!

All transfer procedures described in the following can be performed by one (1) assistant. However, Invacare recommends that the procedures are performed by two (2) assistants whenever possible.



Only lift the patient as high as required. A lower center of gravity provides better stability, makes the patient feel more secure and the lift easier to move.

## 6.2 Attaching the sling to the lift



### WARNING! Risk of Injury

- Usage of wrong or damaged slings can cause the patient to fall or cause injury to assistants.
- Use an Invacare approved sling that is recommended by the individual's doctor, nurse or medical assistant for the comfort and safety of the individual being lifted.
  - Invacare slings and patient lift accessories are specifically designed to be used in conjunction with Invacare patient lifts.
  - After each laundering (in accordance with instructions on the sling), inspect sling(s) for wear, tear, and loose stitching.
  - Bleached, torn, cut, frayed, or damaged slings are unsafe and could result in injury. Discard immediately.
  - DO NOT alter slings.



### WARNING! Risk of Injury

- Improperly attached or adjusted slings can cause the patient to fall or cause injury to assistants.
- Be sure to check the sling attachments each time the sling is removed and replaced, to ensure that it is properly attached before the patient is removed from a stationary object (bed, chair or commode).
  - DO NOT use any kind of plastic back incontinence pad or seating cushion between patient and sling material that may cause the patient to slide out of the sling during transfer.
  - Position the patient in the sling as directed by the instructions provided with the sling.
  - Adjustments for patient safety and comfort should be made before moving the patient.

The loops of the sling may be equipped with color coded straps providing different length, to place the patient in various positions. Match the corresponding colors on each side of the sling for an even lift of the patient.

### Invacare® Stand Assist sling



### WARNING! Risk of Injury

- Using a Stand Assist sling the patient must be able to support the majority of their own weight.
- Make sure the bottom edge of the Stand Assist sling is placed on the lower back of the patient and the patient's arms are outside of the sling.
- The belt must be snug to prevent the patient from sliding out of the sling.

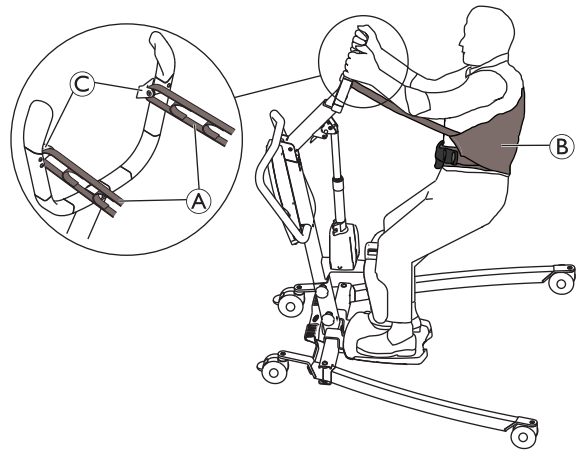

1. Place the loops (A) of the sling (B) over the hooks (C) on the lifting arm.

### Invacare® Transfer Stand Assist sling



### WARNING! Risk of Injury

- Make sure the bottom edge of the Transfer Stand Assist sling is placed at the base of the patient's spine and the patient's arms are outside of the sling.
- Do not raise the patient to a full standing position using the Transfer Stand Assist sling.

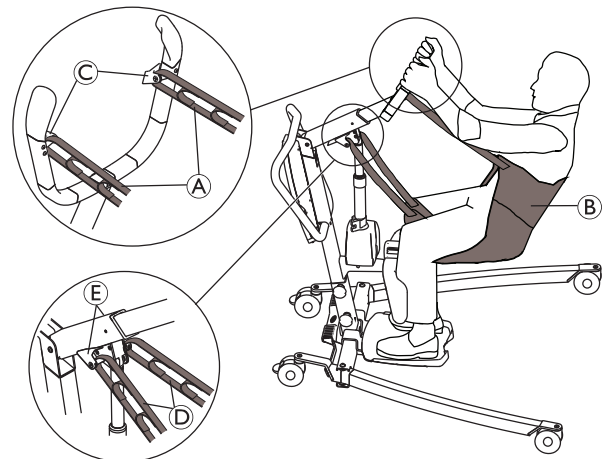

1. Place the upper loops (A) of the sling (B) over the hooks (C) on the lifting arm.
2. Place the lower loops (D) of the sling (B) over the hooks (E) on the boom.

## 6.3 Transferring a patient

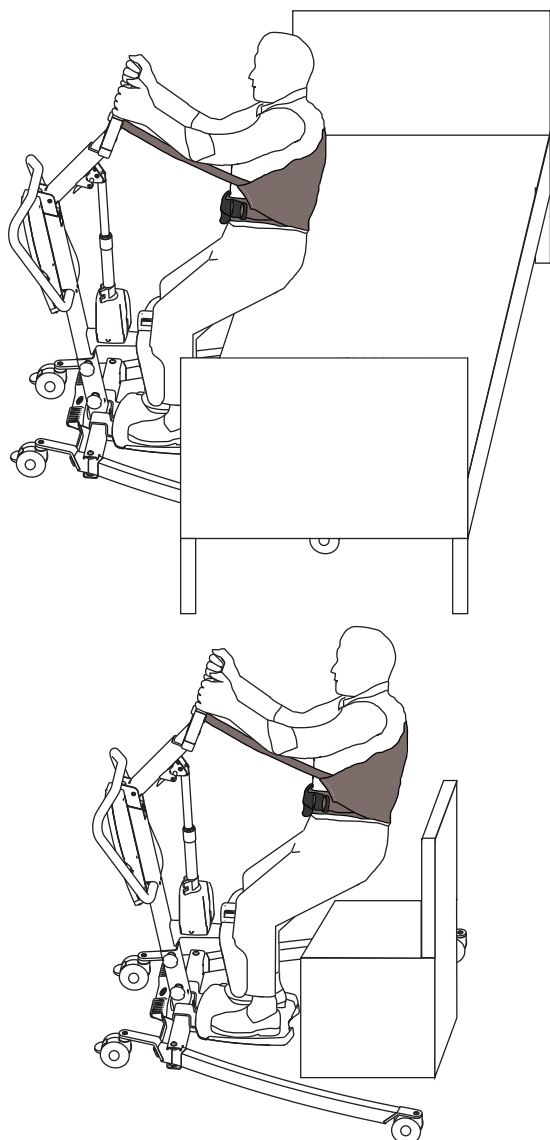

### Lifting from a seating surface

1. Before proceeding, review the information and observe all warnings indicated in *2 Safety, page 4* and *6 Patient Transfer, page 19*.
2. If applicable, ensure the brakes of the stationary object (e.g. bed, wheelchair etc.) are applied.
3. Position the sling around the patient. Refer to your sling user manual.
4. Adjust the lifting arm to the patient height, if required. See *5 Usage, page 13*.
5. Unlock the rear castors of the lift. See *5 Usage, page 13*.
6. Open the legs of the lift to maximum. See *5 Usage, page 13*.
7. Use the push bar to move the lift into position.
  - For transferring a patient from a bed the legs of the lift are placed under the bed
  - For transferring a patient from a wheelchair, commode, chair etc. the legs of the lift are placed on each side of the stationary object.
8. Instruct the patient to place their feet onto the foot plate and their lower legs against the leg support. Assist the patient if necessary and ensure proper placement of the feet on the foot plate

9. Ensure the upper edge of the leg support cushion is placed about 2 fingers below the kneecaps (patella) of the patient. Adjust the height of the leg support if necessary. See *5 Usage, page 13*.
10. If applicable, adjust and apply the leg band around the patients lower legs. See *5 Usage, page 13*.
11. Lower the patient lift for easy attachment of the sling. See *5 Usage, page 13*.
12. Lock the rear castors of the lift. See *5 Usage, page 13*
13. Attach the sling. See *6.2 Attaching the sling to the lift, page 20*.
14. Unlock the rear castors of the lift. See *5 Usage, page 13*.
15. Instruct the patient to hold onto the hand grips on both sides of the lifting arm.
16. Instruct the patient to lean back into the sling.
17. Press the UP arrow button on the hand control to raise the patient above the stationary object. See *5 Usage, page 13*.
18. Before moving the patient, check again to make sure that the sling is properly connected to the hooks of the lifting arm. If any attachments are not properly in place, lower the patient back onto the stationary object and correct the problem.
19. Using the push bar, move the lift away from the stationary object.

### Lowering to a seating surface

1. Before proceeding, review the information and observe all warnings indicated in *2 Safety, page 4* and *6 Patient Transfer, page 19*.
2. Ensure the patient is raised high enough to clear the surface to be transferred to. Raise the patient and/or lower the stationary object if applicable.
3. If applicable, ensure the brakes of the stationary object (e.g. bed, wheelchair etc.) are applied.
4. Position the patient as far over the seating surface as possible.
  - For transferring a patient to a bed the legs of the lift are placed under the bed
  - For transferring a patient to a wheelchair, commode, chair etc. the legs of the lift are placed on each side of the stationary object.
5. Press the DOWN arrow button and lower the patient onto the seating surface. See *5 Usage, page 13*.
6. Lock the rear castors of the lift. See *5 Usage, page 13*.
7. Unhook the sling from all attachment points on the stand assist lift.
8. If applicable, remove the leg band from around the patients lower legs. See *5 Usage, page 13*.
9. Instruct the patient to lift their feet off of the foot plate. Assist the patient if necessary.
10. Unlock the rear castors of the lift. See *5 Usage, page 13*.
11. Move the lift away from the stationary object.
12. Remove the sling from around the patient.



The patient can remain in the Invacare® Stand Assist sling while using the commode. In this case the sling must not be placed around the patient again before lifting from the commode.

---

## 7 Transportation and Storage

---

### 7.1 General information

During transportation, or when the patient lift is not to be used for some time, the emergency stop button should be pushed in.

A disassembled lift can be located in the packaging box, for transportation and storage.

The patient lift must be stored at normal room temperature. If it is stored in a damp, cold or wet environment then the motor and other mounting parts may be prone to corrosion. See *11.4 Environmental conditions, page 30*.

### 7.2 Disassembling the lift

1. Remove the leg spreader lever if attached.
2. Lower the boom and close the legs completely.
3. Activate the emergency stop button and apply castor brakes.
4. Adjust the lifting arm to minimum length. See *5.5 Adjusting the lifting arm to patient body height, page 13*.
5. Reverse the procedure described in *4.6 Installing the leg support, page 11*
6. Reverse the procedure described in *4.3 Installing the mast to the base, page 10*.
7. Reverse the procedure described in *4.4 Installing the foot plate, page 11*.



## 8 Maintenance

### 8.1 General maintenance information



#### WARNING!

##### Risk of injury or damage

- Do not perform any maintenance or service procedures while the product is in use.

Follow the maintenance procedures described in this manual to keep your product in continuous service.

Further maintenance and inspection procedures, to be performed by a qualified technician, are described in the service manual of this product. Service manuals can be obtained from Invacare.

### 8.2 Daily inspections



#### WARNING!

##### Risk of injury or damage

Damaged or worn parts can affect the safety of the lift.

- The patient lift should be checked each time it is used.
- Do not use the lift if damage is found or you question the safety of any part of the lift. Contact your Invacare provider immediately and ensure the lift is not used until repairs are made.

#### 8.2.1 Daily Inspection Checklist

- Visually inspect the patient lift. Check all parts for external damage or wear.
- Check all hardware, attachment points and stressed parts, such as slings, hooks and any pivot points for signs of wear, cracking, fraying, deformation or deterioration.
- Verify that the hand control is functional (lifting and leg movements).
- Charge the battery every day the lift is used.
- Check the emergency stop function.
- Check the service light (CBJ Care control unit only).



The service light is indicated by a wrench symbol on the control unit and if applicable on the hand control.

- If the service light is flashing yellow the lift requires service. Do not use the lift and contact your Invacare provider for service.
- If the service light is not flashing the lift is ready for use.

### 8.3 Cleaning and Disinfection

#### 8.3.1 General Safety Information



#### CAUTION!

##### Risk of Contamination

- Take precautions for yourself and use appropriate protective equipment.



#### CAUTION!

##### Risk of Electric Shock and Product Damage

- Switch off the device and disconnect from mains, if applicable.
- When cleaning electronic components consider their protection class regarding water ingress.
- Make sure that no water splashes to the plug or the wall outlet.
- Do not touch the power socket with wet hands.



#### NOTICE!

Wrong fluids or methods can harm or damage the product.

- All cleaning agents and disinfectants used must be effective, compatible with one another and must protect the materials they are used to clean.
- Never use corrosive fluids (alkalines, acid etc.) or abrasive cleaning agents. We recommend an ordinary household cleaning agent such as dishwashing liquid, if not specified otherwise in the cleaning instructions.
- Never use a solvent (cellulose thinner, acetone etc.) that changes the structure of the plastic or dissolves the attached labels.
- Always make sure that the product is completely dried before taking into use again.



For cleaning and disinfection in clinical or long-term care environments, follow your in-house procedures.

#### 8.3.2 Cleaning Intervals



#### NOTICE!

Regular cleaning and disinfection enhance smooth operation, increases the service life and prevents contamination.

Clean and disinfect the product:

- regularly while in use;
- before and after any service procedure;
- when it has been in contact with any body fluids;
- before using it for a new user.

#### 8.3.3 Cleaning instructions



#### NOTICE!

- The product does not tolerate cleaning in automatic washing systems, with high-pressure cleaning equipment or steam.

#### Cleaning the lift

Method: Wipe off with a damp cloth or soft brush.

Max. temperature: 40 °C

Solvent/chemicals: Ordinary household cleaning agent and water.

Drying: Wipe dry with a soft cloth.

#### Cleaning the sling

Refer to the washing instructions on the sling and to the sling manual for cleaning details.

### 8.3.4 Disinfection Instructions

#### In Domestic Care

- Disinfectant: We recommend using an alcohol-based surface disinfectant (with 70-90% alcohol).

 Read the instructions on the label of your disinfectant. It provides information on the activity spectrum (bacteria, fungi and/or viruses), material compatibility and the correct exposure time.

1. Ensure the surfaces are cleaned before disinfection.
2. Moisten a soft cloth and wipe-disinfect all accessible surfaces and keep them moistened for the exposure time stated on the label of the disinfectant.
3. Allow the product to air-dry.

#### In Institutional Care

Follow your in-house disinfection procedures and only use the disinfectants and methods specified therein.

### 8.4 Service Interval

**WARNING!****Risk of injury or damage**

Service must be performed only by a qualified technician.

- Contact your Invacare provider for service.

Service must be performed at least every 12 months unless otherwise stated in local requirements.

## 9 After Use

### 9.1 Disposal

**WARNING!****Environmental Hazard**

Device contains batteries.

This product may contain substances that could be harmful to the environment if disposed of in places (landfills) that are not appropriate according to legislation.

- DO NOT dispose of batteries in normal household waste.
- DO NOT throw batteries into a fire.
- Batteries **MUST** be taken to a proper disposal site. The return is required by law and free of charge.
- Only dispose of discharged batteries.
- Cover terminals of lithium batteries prior to disposal.
- For information on the battery type see battery label or chapter 11 *Technical Data*, page 28.

Be environmentally responsible and recycle this product through your recycling facility at its end of life.

Disassemble the product and its components, so the different materials can be separated and recycled individually.

The disposal and recycling of used products and packaging must comply with the laws and regulations for waste handling in each country. Contact your local waste management company for information.

### 9.2 Reconditioning

This product is suitable for reuse. To recondition the product for a new user, carry out the following actions:

- Cleaning and disinfection
- Inspection according to service plan

For detailed information about inspection, cleaning and disinfection, consult the user manual and service manual for this product.

Make sure that the user manual is handed over with the product. If any damage or malfunction is detected, do not reuse the product.

## 10 Troubleshooting

### 10.1 Identifying faults and possible solutions

| Symptoms  | Faults   | Solution   |
|---|--|--|
| Patient lift feels loose.   | Mast/ Base joint loose.  | Retighten the Mast / Base connection. See 4.3 <i>Installing the mast to the base, page 10</i>            |
|   | Manual leg spreader mechanism loose  | Contact your Invacare provider.  |
| Castors/ Brakes noisy or stiff.   | Fluff or debris in bearings.   | Clean castors from fluff and debris.   |
|   | Castors / brakes are damaged   | Contact your Invacare provider   |
| Noisy or dry sound from pivots.   | Pivots are worn or damaged   | Contact your Invacare provider.  |
| Electric actuator fails to raise or lower the boom or legs fail to open or close when button is pressed | Hand control or actuator connector loose.                                    | Connect hand control or actuator connector. Ensure connectors are seated properly and fully connected.   |
|   | Battery low.   | Charge the battery. See 5.9 <i>Charging the battery, page 16.</i>  |
|   | Emergency stop button is pressed in.   | Rotate the emergency stop button clockwise until it pops out.  |
|   | Battery not connected properly to control unit.                              | Reconnect the battery to the control unit. See 5.9.4 <i>Optional battery charger, page 17.</i>           |
|   | The connecting terminals are damaged.  | Contact your Invacare provider.  |
|   | Power cord connected to power outlet.  | Disconnect power cord from power outlet.   |
|   | Boom or leg actuator is damaged  | Contact your Invacare provider.  |
|   | Max. load is exceeded  | Reduce the load (and the lift will function normally).   |
| Unusual noise from actuator.  | Actuator is damaged  | Contact your Invacare provider.  |
| Boom will not lower when activating the manual emergency release  | Boom requires a minimum weight load to lower from the uppermost position.    | Pull down slightly on the boom.  |
| The control unit emits a beeping sound during lifting, and the motor stops.                             | Max. load is exceeded  | Reduce the load (and the lift will function normally).   |
| Battery does not charge   | Power cord is not properly connected to the control unit/and or power outlet | Ensure connectors are seated properly and fully connected. See 5.9 <i>Charging the battery, page 16.</i> |
|   | Power cord is damaged  | Contact your Invacare provider.  |
| Lifting arm can not be adjusted   | The red lever on the boom is not pushed and held upwards                     | See 5.5 <i>Adjusting the lifting arm to patient body height, page 13</i>                                 |
|   | Lifting arm is already at the maximum or minimum position                    | See 5.5 <i>Adjusting the lifting arm to patient body height, page 13.</i>                                |
|   | The adjustment mechanism is damaged  | Contact your Invacare provider   |
|   | Boom is in wrong position  | Move the boom to horizontal position. See 5.3 <i>Raising/Lowering an Electric Lift, page 13.</i>         |

| Symptoms                                     | Faults   | Solution   |
|--|--|--|
| Leg support can not be installed or adjusted | The release handle not pushed and held upwards   | See 4.6 <i>Installing the leg support, page 11.</i>  |
|  | The adjustment mechanism is damaged              | Contact your Invacare provider   |
|  | Leg band is clogging the back of the leg support | Clear the back of the leg support  |
| Mast can not be assembled on the base        | Boom pointing in the wrong direction             | Bring the boom in correct position. See 4.3 <i>Installing the mast to the base, page 10.</i> |
| Lift does not roll                           | The castors are locked                           | Unlock the castors. See 5.2 <i>Locking/Unlocking the Rear Castors, page 13</i>               |

†† Contact your Invacare provider if the above does not solve your problems.

## 11 Technical Data

### 11.1 Maximum safe working load

|  | ISA™ COMPACT | ISA™ STANDARD | ISA™ PLUS | ISA™ XPLUS |
|---|--------------|---------------|-----------|------------|
| Max. Safe Working Load (patient + sling)  | 140 KG       | 160 kg        | 180 kg    | 200 kg     |

### 11.2 Dimensions and Weights

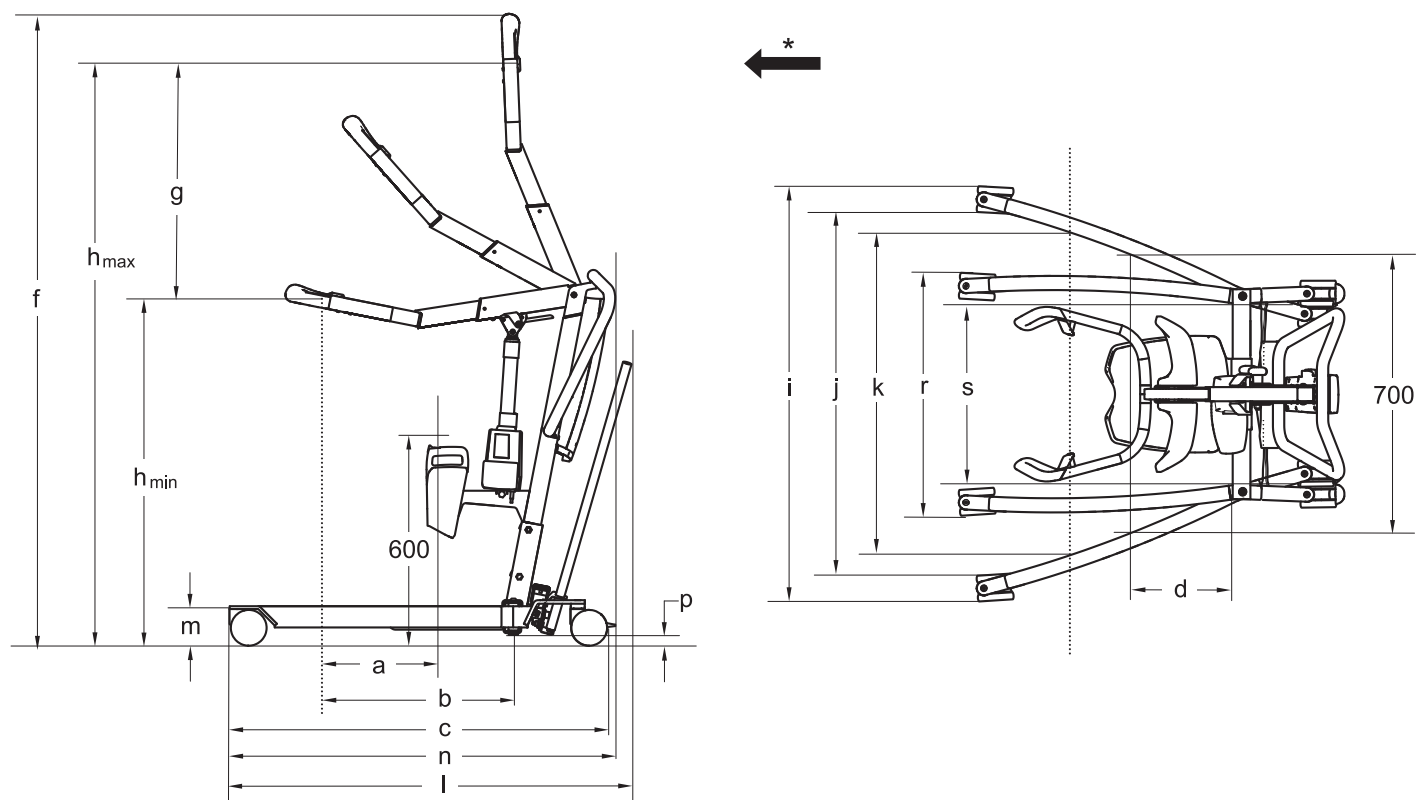

\* Forward direction

| Dimensions [mm]                                   | ISA™ COMPACT | ISA™ STANDARD | ISA™ PLUS   | ISA™ XPLUS  |
|---|--------------|---------------|-------------|-------------|
| Front / rear castor diameter                      | 100 / 100    | 100 / 100     | 100 / 100   | 100 / 125   |
| Max. reach at 600 mm (a)*                         | 130 - 250    | 130 - 250     | 130 - 250   | 130 - 250   |
| Max. reach from base (b)*                         | 360 - 480    | 360 - 480     | 360 - 480   | 360 - 480   |
| Base length (c)                                   | 925          | 1080          | 1220        | 1280        |
| Total length without lever (n)                    | 925          | 1090          | 1230        | 1280        |
| Total length with lever (l)*                      | 980 - 1000   | 1145          | 1290        | N/A         |
| Reach from base with legs spread to 700 mm (d)    | 420          | 225           | 225         | 225         |
| Max. height (f)*                                  | 1675 - 1785  | 1675 - 1785   | 1675 - 1785 | 1675 - 1785 |
| Lifting range (g)*                                | 530 - 660    | 530 - 660     | 530 - 660   | 530 - 660   |
| Min. height at Sling Hook-up (h <sub>min</sub> )* | 965 - 980    | 965 - 980     | 965 - 980   | 965 - 980   |
| Max. height at Sling Hook-up (h <sub>max</sub> )* | 1495 - 1640  | 1495 - 1640   | 1495 - 1640 | 1495 - 1640 |
| Total width (legs open), external measure (i)     | 885          | 1110          | 1170        | 1170        |
| Total width (legs open), internal measure(j)      | 735          | 960           | 1020        | 1020        |
| Total width (legs closed), external measure (r)   | 535          | 635           | 640         | 640         |
| Min. internal width (s)                           | 380          | 495           | 495         | 495         |

| Dimensions [mm]                      | ISA™ COMPACT | ISA™ STANDARD | ISA™ PLUS | ISA™ XPLUS |
|--------------------------------------|--------------|---------------|-----------|------------|
| Internal width at maximum reach (k)* | 640 - 725    | 775 - 870     | 775 - 870 | 775 - 870  |
| Turning diameter                     | 1060         | 1260          | 1400      | 1430       |
| Height to upper edge of legs (m)     | 115          | 115           | 115       | 115        |
| Min. free height (p)                 | 35           | 35            | 35        | 35         |

\*Range depending on fully shortened to fully extended position of lifting arm

| Weights – Main Parts [kg]                                 | ISA™ COMPACT | ISA™ STANDARD | ISA™ PLUS | ISA™ XPLUS |
|---|--------------|---------------|-----------|------------|
| Total weight*   | 43 - 45      | 48 - 50       | 49 - 51   | 52         |
| Weight, mast with CBJ Home                                | 19           |               |           | n/a        |
| Weight, mast with CBJ1 / 2 / Care incl. lead acid battery | 20           |               |           |            |
| Weight manual leg section                                 | 15           | 20            | 21        | n/a        |
| Lever for manual leg spreader                             | 1            |               |           | n/a        |
| Weight electrical leg section                             | n/a          | 20            | 21        | 23         |
| Leg support   | 5            |               |           |            |
| Foot plate (high, low and inclined)                       | 4            |               |           |            |

\* Range depending on configuration

### 11.3 Electrical System

|                                  | ISA™ COMPACT   | ISA™ STANDARD                                      | ISA™ PLUS  | ISA™ XPLUS                     |
|----------------------------------|--|--|--|--------------------------------|
| Voltage output                   | 24 V DC  |  |  |                                |
| Voltage supply                   | 100 – 240 V AC, 50/60 Hz   |  |  |                                |
| Maximum current input            | 280 mA (for CBJ Home) / 400 mA (for CBJ2)                                | 280 mA (for CBJ Home) / 400 mA (for CBJ1 and CBJ2) | 280 mA (for CBJ Home) / 400 mA (for CBJ1, CBJ2 and CBJ Care) | 400 mA (for CBJ1 and CBJ care) |
| Protection class (entire device) | IPX4 - The system is protected against water splashed from any direction |  |  |                                |
| Insulation class                 | Class II equipment   |  |  |                                |



|   | ISA™ COMPACT  | ISA™ STANDARD   | ISA™ PLUS  | ISA™ XPLUS                        |
|---|---|---|--|-----------------------------------|
| Type B Applied Part                     | Applied part complying with the specified requirements for protection against electrical shock according to IEC60601-1. |   |  |                                   |
| Sound level                             | 45 – 50 dB(A)   |   |  |                                   |
| Working ability                         | 82 full lifts (with battery between 100% – 50% of full capacity)  |   |  |                                   |
| Intermittent (periodic motor operation) | 10%, max. 2 min/18 min  |   |  |                                   |
| Battery specifications                  | 2 x 12 V / 2.9 Ah   |   |  |                                   |
| Battery type                            | Lead acid (service free, sealed)  |   |  |                                   |
| Manual emergency lowering               | Yes(at bottom of actuator)  |   |  |                                   |
| Electric emergency lowering / lifting   | Yes / No (for CBJ2 and CBJ Home)  | Yes / Yes (for CBJ1) Yes / No (for CBJ2 and CBJ Home) | Yes / Yes (for CBJ1 and CBJ Care) Yes / No (for CBJ2 and CBJ Home) | Yes / Yes (for CBJ1 and CBJ care) |
| Power Consumption                       | while charging: max. 19 W<br>in standby: max. 2.5 W   |   |  |                                   |
| Lifting Speed - without load*           | 38 – 51 mm/s  |   |  |                                   |
| Lifting Speed - with 80 kg person       | 36 – 46 mm/s  |   |  |                                   |

\* Range depending on fully shortened to fully extended position of lifting arm

## 11.4 Environmental conditions

|                      | Storage and transportation | Operation       |
|----------------------|----------------------------|-----------------|
| Temperature          | -10 °C to +50 °C           | +5 °C to +40 °C |
| Relative humidity    | 20% to 80%, not condensing |                 |
| Atmospheric pressure | 700 hPa to 1060 hPa        |                 |



Allow the product to reach operation temperature before usage:

- Warming up from minimum storage temperature might take more than 30 minutes.
- Cooling down from maximum storage temperature might take more than 5 minutes.

## 11.5 Materials

| Component                      | Material              |
|--------------------------------|-----------------------|
| Base, legs, mast and boom      | Steel (powder-coated) |
| Boom connector, bolts and nuts | Steel, zinc-plated    |
| Hand grips                     | TPE                   |
| Sling hooks                    | TPU                   |
| Leg support cushion            | Selfskin PU           |
| Foot plate cover               | PVC, PU               |

| Component   | Material                                   |
|---|--|
| Actuator housing, hand control, mast protector, castors and other plastic parts | Material according to marking (PA, PP, PE) |
| Leg band  | PA, PES, PVC, PU                           |

All components of the product are either corrosion resistant or corrosion protected.

## 11.6 Operating forces of controls

| Control   | Operating force |
|---|-----------------|
| Buttons on control unit                         | 4 N             |
| Buttons on hand control                         | 4 N             |
| Foot pedal on ISA™ COMPACT with 100 mm castors* | 270 N           |
| Leg spreader lever on ISA™ COMPACT              | 64 N            |
| Leg spreader lever on ISA™ STANDARD             | 70 N            |
| Leg spreader lever on ISA™ PLUS                 | 85 N            |

\* For all other models and castor sizes, a lever for the manual leg spreader is mandatory.

## 12 Electromagnetic Compatibility

### 12.1 General EMC information

Medical Electrical Equipment needs to be installed and used according to the EMC information in this manual.

This product has been tested and found to comply with EMC limits specified by IEC/EN 60601-1-2 for Class B equipment.

Portable and mobile RF communications equipment can affect the operation of this product.

Other devices may experience interference from even the low levels of electromagnetic emissions permitted by the above standard. To determine if the emission from this product is causing the interference, run and stop running this product. If the interference with the other device operation stops, then this product is causing the interference. In such rare cases, interference may be reduced or corrected by the following:

- Reposition, relocate, or increase the separation between the devices.

### 12.2 Electromagnetic emission

#### Guidance and manufacturer's declaration

This product is intended for use in the electromagnetic environment specified below. The customer or the user of this product should assure that it is used in such an environment.

| Emissions test  | Compliance | Electromagnetic environment - guidance   |
|---|------------|--|
| RF emissions<br>CISPR 11  | Group I    | This product uses RF energy only for its internal function. Therefore, its RF emissions are very low and are not likely to cause any interference in nearby electronic equipment.  |
| RF emissions<br>CISPR 11  | Class B    | This product is suitable for use in all establishments including domestic establishments and those directly connected to the public low-voltage power supply network that supplies buildings used for domestic purposes. |
| Harmonic<br>emissions IEC<br>61000-3-2                            | Class A    |  |
| Voltage<br>fluctuations<br>/flicker<br>emissions IEC<br>61000-3-3 | Complies   |  |

### 12.3 Electromagnetic Immunity

#### Guidance and manufacturer's declaration

This product is intended for use in the electromagnetic environment specified below. The customer or the user of this product should assure that it is used in such an environment.

| Immunity test                                       | Test / Compliance level  | Electromagnetic environment – guidance   |
|---|--|--|
| Electrostatic<br>discharge (ESD)<br>IEC 61000-4-2   | ± 8 kV contact<br>± 2 kV, ± 4 kV, ± 8 kV, ± 15 kV<br>air   | Floors should be wood, concrete or ceramic tile. If floors are covered with synthetic material, the relative humidity should be at least 30 %. |
| Electrostatic<br>transient / burst<br>IEC 61000-4-4 | ± 2 kV for power supply lines;<br>100 kHz repetition frequency<br>± 1 kV for input / output lines;<br>100 kHz repetition frequency | Mains power quality should be that of a typical commercial or hospital environment.  |
| Surge<br>IEC 61000-4-5                              | ± 1 kV line to line<br>± 2 kV line to earth  | Mains power quality should be that of a typical commercial or hospital environment.  |

| Immunity test  | Test / Compliance level   | Electromagnetic environment – guidance  |
|--|---|---|
| Voltage dips, short interruptions and voltage variations on power supply input lines<br>IEC 61000-4-11 | < 0% $U_T$ for 0,5 cycle at 45° steps<br>0% $U_T$ for 1 cycles<br>70% $U_T$ for 25 / 30 cycles<br>< 5% $U_T$ for 250 / 300 cycles | Mains power quality should be that of a typical commercial or hospital environment. If the user of this product requires continued operation during power mains interruptions, it is recommended that the product is powered from an un-interruptible power supply or a battery.<br><br>$U_T$ is the a. c. mains voltage prior to application of the test level.  |
| Power frequency (50/60 Hz) magnetic field<br>IEC 61000-4-8   | 30 A/m  | Power frequency magnetic fields should be at levels characteristic of a typical location in a typical commercial or hospital environment.   |
| Conducted RF<br>IEC 61000-4-6  | 3 V<br>150 kHz to 80 Mhz  | Field strengths from fixed transmitters, such as base stations for radio (cellular/cordless) telephones and land mobile radios, amateur radio, AM and FM radio broadcast and TV broadcast cannot be predicted theoretically with accuracy. To assess the electromagnetic environment due to fixed RF transmitters, an electromagnetic site survey should be considered. If the measured field strength in the location in which this product is used exceeds the applicable RF compliance level above, this product should be observed to verify normal operation. If abnormal performance is observed, additional measures may be necessary, such as reorienting or relocating this product. |
|  | 6 V<br>in ISM & amateur radio bands   |   |
| Radiated RF<br>IEC 61000-4-3   | 10 V/m<br>80 Mhz to 2,7 GHz   | Interference may occur in the vicinity of equipment marked with the following symbol: <br><br>Portable and mobile RF communications equipment should be used no closer than 30 cm to any part of this product including cables.  |
|  | 385 MHz - 5785 MHz test specifications for immunity to RF wireless communication equipment refer to table 9 of IEC 60601-1-2      |   |

 These guidelines may not apply in all situations. Electromagnetic propagation is affected by absorption and reflection from structures, objects and people.

## 12.4 EMC test specifications

IEC 60601-1-2 — Table 9

| Test Frequency (MHz) | Band a) (MHz) | Service a)  | Modulation                                    | Immunity test level (V/m) |
|----------------------|---------------|---|---|---------------------------|
| 385                  | 380 - 390     | TETRA 400   | Pulse modulation <sup>b)</sup> 18 Hz          | 27                        |
| 450                  | 430 - 470     | GMRS 460, FRS 460   | FM <sup>c)</sup> ± 5 kHz deviation 1 kHz sine | 28                        |
| 710<br>745<br>788    | 704 - 787     | LTE Band 13, 17   | Pulse modulation <sup>b)</sup> 217 Hz         | 9                         |
| 810<br>870<br>930    | 800 - 960     | GSM 800/900, TETRA 800, iDEN 820, CDMA 850, LTE Band 5          | Pulse modulation <sup>b)</sup> 18 Hz          | 28                        |
| 1720<br>1845<br>1970 | 1700 - 1990   | GSM 1800; CDMA 1900; GSM 1900; DECT; LTE Band 1, 3, 4, 25; UMTS | Pulse modulation <sup>b)</sup> 217 Hz         | 28                        |
| 2450                 | 2400 - 2570   | Bluetooth, WLAN, 802.11, b/g/n, RFID, 2450, LTE, Band 7         | Pulse modulation <sup>b)</sup> 217 Hz         | 28                        |

| Test Frequency (MHz) | Band a) (MHz) | Service a)     | Modulation                 | Immunity test level (V/m) |
|----------------------|---------------|----------------|----------------------------|---------------------------|
| 5240<br>5500<br>5785 | 5100 - 5800   | WLAN 802.11a/n | Pulse modulation b) 217 Hz | 9                         |

 If necessary to achieve the immunity test level, the distance between the transmitting antenna and the Medical Electrical Equipment or System may be reduced to 1 m. The 1 m test distance is permitted by IEC 61000-4-3.

a) For some services, only the uplink frequencies are included.

b) The carrier shall be modulated using a 50 % duty cycle square wave signal.

c) As an alternative to FM modulation, 50 % pulse modulation at 18 Hz may be used because while it does not represent actual modulation, it would be worst case.





**United Kingdom & Ireland:**

Invacare Limited  
Pencoed Technology Park, Pencoed  
Bridgend CF35 5AQ  
Tel: (44) (0) 1656 776 200  
uk@invacare.com  
www.invacare.co.uk

**Belgium & Luxemburg:**

Invacare nv  
Autobaan 22  
B-8210 Loppem  
Tel: (32) (0)50 83 10 10  
Fax: (32) (0)50 83 10 11  
marketingbelgium@invacare.com  
www.invacare.be

**Danmark:**

Invacare A/S  
Sdr. Ringvej 37  
DK-2605 Brøndby  
Tel: (45) (0)36 90 00 00  
Fax: (45) (0)36 90 00 01  
denmark@invacare.com  
www.invacare.dk

**Deutschland:**

Invacare GmbH  
Am Achener Hof 8  
D-88316 Isny  
Tel: (49) (0)7562 700 0  
kontakt@invacare.com  
www.invacare.de

**Österreich:**

Invacare Austria GmbH  
Herzog-Odilo-Straße 101  
A-5310 Mondsee  
Tel: (43) 6232 5535 0  
Fax: (43) 6232 5535 4  
info-austria@invacare.com  
www.invacare.at

**Schweiz / Suisse / Svizzera:**

Invacare AG  
Neuhofweg 51  
CH-4147 Aesch BL  
Tel: (41) (0)61 487 70 80  
Fax: (41) (0)61 488 19 10  
switzerland@invacare.com  
www.invacare.ch

**España:**

Invacare S.A.  
Avenida del Oeste, 50 – 1<sup>a</sup>-1a  
Valencia-46001  
Tel: (34) 972 493 214  
contactsp@invacare.com  
www.invacare.es

**France:**

Invacare Poirier SAS  
Route de St Roch  
F-37230 Fondettes  
Tel: (33) (0)2 47 62 64 66  
contactfr@invacare.com  
www.invacare.fr

**Italia:**

Invacare Mecc San s.r.l.,  
Via dei Pini 62,  
I-36016 Thiene (VI)  
Tel: (39) 0445 38 00 59  
servizioclienti@invacare.com  
www.invacare.it

**Nederland:**

Invacare BV  
Galvanistraat 14-3  
NL-6716 AE Ede  
Tel: (31) (0)318 695 757  
nederland@invacare.com  
www.invacare.nl

**Norge:**

Besøksadresse:  
(Office addresses)  
Invacare AS  
Brynsveien 16  
0667 Oslo  
Tel: (47) 22 57 95 00  
norway@invacare.com  
www.invacare.no

**Norge:**

Vareleveringsadresse:  
(Storage / Technical dep)  
Østensjøveien 19  
0661 Oslo  
eknisk@invacare.com  
www.invacare.no

**Portugal:**

Invacare Lda  
Rua Estrada Velha, 949  
P-4465-784 Leça do Balio  
Tel: (351) (0)225 193 360  
portugal@invacare.com  
www.invacare.pt

**Suomi:**

Camp Mobility  
Patamäenkatu 5, 33900 Tampere  
Puhelin 09-35076310  
info@campmobility.fi  
www.campmobility.fi

**Sverige:**

Invacare AB  
Fagerstagatan 9  
S-163 53 Spånga  
Tel: (46) (0)8 761 70 90  
Fax: (46) (0)8 761 81 08  
sweden@invacare.com  
www.invacare.se

**Australia:**

Invacare Australia Pty. Ltd.  
Unit 18/12 Stanton Road,  
Seven Hills, NSW 2147,  
Australia  
Phone: 1800 460 460  
Fax: 1800 814 367  
orders@invacare.com.au  
www.invacare.com.au

**EU Export:**

Invacare Poirier SAS  
Route de St Roch  
F-37230 Fondettes  
Tel: (33) (0)2 47 62 69 80  
serviceclient\_export@invacare.com  
www.invacare.eu.com

**New Zealand:**

Invacare New Zealand Ltd  
4 Westfield Place, Mt Wellington  
1060  
New Zealand  
Phone: 0800 468 222  
Fax: 0800 807 788  
sales@invacare.co.nz  
www.invacare.co.nz



Invacare UK Operations Limited  
Unit 4, Pencoed Technology Park,  
Pencoed  
Bridgend CF35 5AQ  
UK



Invacare Portugal, Lda  
Rua Estrada Velha 949  
4465-784 Leça do Balio  
Portugal

