

Invacare® NordBed™ Kid

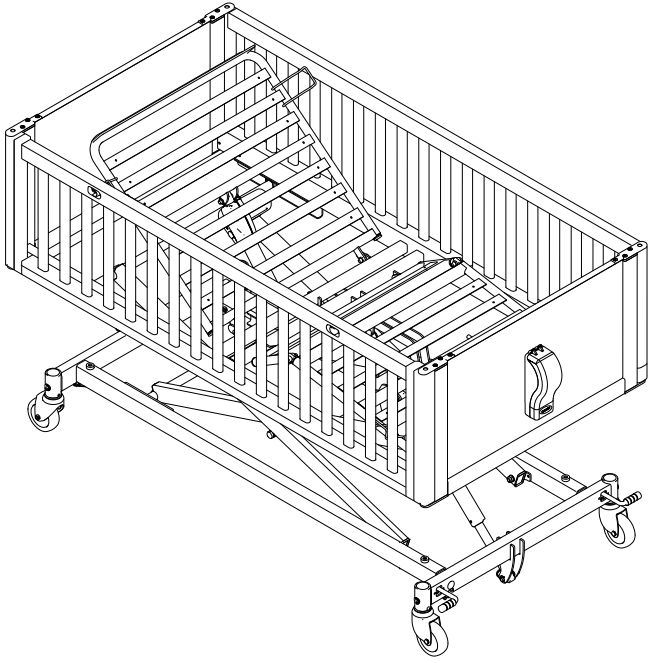

en Children's Bed
Service Manual

PROVIDER: Keep this manual.
The procedures in this manual MUST be performed by a qualified technician.



Yes, you can.®

©2022 Invacare Corporation

All rights reserved. Republication, duplication or modification in whole or in part is prohibited without prior written permission from Invacare. Trademarks are identified by ™ and ®. All trademarks are owned by or licensed to Invacare Corporation or its subsidiaries unless otherwise noted.

Making Life's Experiences Possible is a registered trademark in the U.S.A.

Contents

1 General	4
1.1 Introduction	4
1.2 Symbols in this Document	4
2 Safety	5
2.1 General Safety Information	5
2.2 Main Parts of the Bed	5
3 Setup	6
3.1 General safety information	6
3.2 Installing Bed Ends	6
3.3 Installing side rails	7
3.3.1 Installing the Fixed Side Rail	7
3.3.2 Installing the Lowering Side Rail	7
3.3.3 Installing the Side Rail with Foldable Doors	8
3.4 Adjusting Bed Ends	8
4 Transportation and Storage	10
4.1 Dismounting the Mattress Support Platform	10
4.2 Mounting the Mattress Support Platform	11
5 Servicing	12
5.1 General servicing information	12
5.1.1 Checklist - Maintenance	12
5.2 Inspection after relocation - Prepare for new user	12
5.2.1 Checklist - After relocation	12
5.3 Cleaning and Disinfection	12
5.3.1 General safety information	12
5.3.2 Cleaning Intervals	13
5.3.3 Cleaning Instructions	13
5.3.4 Disinfection Instructions	13
5.3.5 Lubrication	13
5.4 Control Unit	13
5.4.1 Resetting the control unit	14

1 General

1.1 Introduction

This document contains important information about assembly, adjustment and advanced maintenance of the product. To ensure safety when handling the product, read this document and the user manual carefully and follow the safety instructions.

Find the user manual on Invacare’s website or contact your Invacare representative. See addresses at the end of this document.

Invacare reserves the right to alter product specifications without further notice.

Before reading this document, make sure you have the latest version. You find the latest version as a PDF on the Invacare website.

For pre-sale and user information, see the user manual.

For more information about the product, for example product safety notices and product recalls, contact your Invacare representative. See addresses at the end of this document.

1.2 Symbols in this Document

Symbols and signal words are used in this document and apply to hazards or unsafe practices which could result in personal injury or property damage. See the information below for definitions of the signal words.



WARNING

Indicates a hazardous situation that could result in serious injury or death if it is not avoided.



CAUTION

Indicates a hazardous situation that could result in minor or slight injury if it is not avoided.



NOTICE

Indicates a hazardous situation that could result in damage to property if it is not avoided.



Tips and Recommendations

Gives useful tips, recommendations and information for efficient, trouble-free use.

Other Symbols



UK Responsible Person

Indicates if a product is not manufactured in the UK.



Triman

Indicates recycling and sorting rules (only relevant for France).

2 Safety

2.1 General Safety Information



WARNING!

Risk of injury or damage to property

- The procedures in this manual must only be performed by a qualified technician.
- Use only original accessories and spare parts.
- Do not handle this product or any available optional equipment without first completely reading and understanding these instructions and any additional instructional material such as user manuals, installation manuals or instruction sheets supplied with this product or optional equipment.
- After each assembly, check that all fittings are properly tightened and that all parts have the correct function.



WARNING!

Risk of contamination

- Clean and disinfect the product before servicing.



NOTICE!

Assembly of accessories might not be described in this service manual. Refer to the manual, delivered with the accessory.

- Additional manuals can be ordered from Invacare. See addresses at the end of this document.
- Due to regional differences, refer to your local Invacare catalog or website for available accessories or contact your local Invacare representative. See addresses at the end of this document.



NOTICE!

Some replacement parts are only available as a kit. Always use the complete new kit when replacing a part.

- Spare parts can be ordered from Invacare. Refer to your local Invacare website to access the electronic spare parts catalogue (ESPC).



NOTICE!

Refer to the user manual of this product for information on

- Technical data
- Product components
- Labels
- Additional safety instructions



The information contained in this document is subject to change without notice.

2.2 Main Parts of the Bed

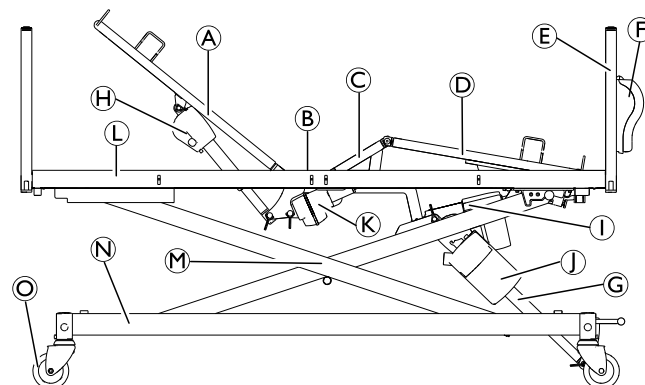

Parts of standard bed:

- Ⓐ Back section
- Ⓑ Seat section
- Ⓒ Thigh section
- Ⓓ Leg section
- Ⓔ Bed end
- Ⓕ Hand Control Box
- Ⓖ Height adjustment actuator
- Ⓗ Back section actuator
- Ⓘ Leg section actuator
- Ⓝ Control unit
- Ⓚ Thigh section actuator
- Ⓛ Mattress support platform
- Ⓜ Lifting mechanism
- Ⓝ Base frame
- Ⓞ Castor

Hand Control (not shown)

Side rails (not shown)

3 Setup

3.1 General safety information



WARNING!

Risk of injury or damage

Damaged parts may affect the safety of the product.

- Check all parts for shipping damage before use.
- In case of damage, do not use the product and contact your Invacare provider for further instructions.

3.2 Installing Bed Ends



Allen key (3 mm, 4 mm)

1.

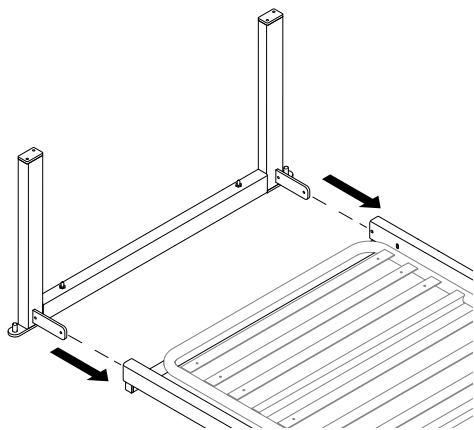

Insert the connectors of the bed end frame into the lateral square tubes of the mattress support platform.

2.

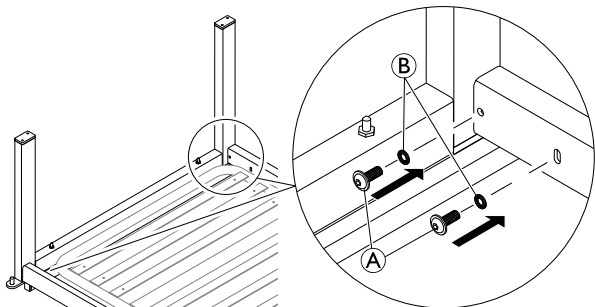

On both sides of the bed insert the screws (A) with their washers (B) and tighten them until the bed end frame is stable but still slightly adjustable in angle.



Do not completely tighten screws (A) in this step. See step 4.

3.

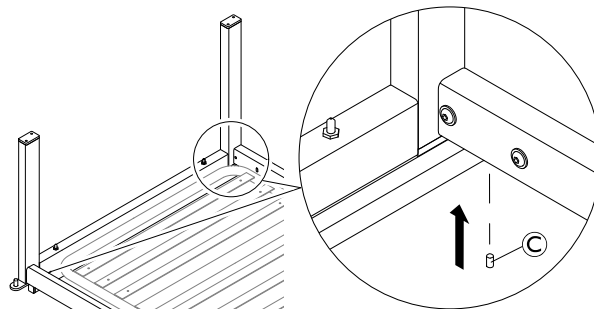

Position the bed end frame at an 90° angle to the mattress support platform and on both sides of the bed insert the grub screw (C) until feeling a resistance.



The grub screws (C) are used to adjust the angle between the bed end frame and the mattress support platform for proper fitting and function of the side rails. See 3.4 *Adjusting Bed Ends*, page 8.

4. Tighten the screws (A) on both sides of the bed.

5.

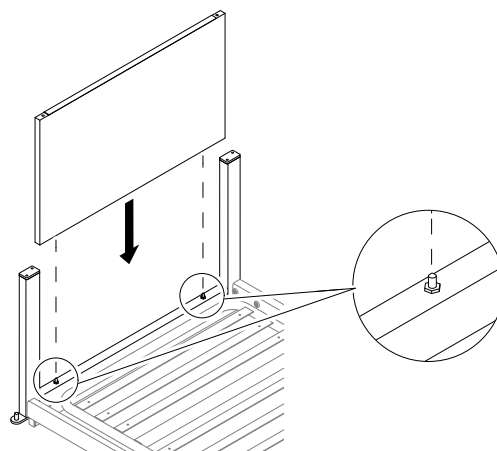

NOTICE!

The bed end board with the hand control box attached must be placed at the foot end of the bed with the hand control box facing to the outside.

Insert the bed end board into the bed end frame onto the 2 pins.

6.

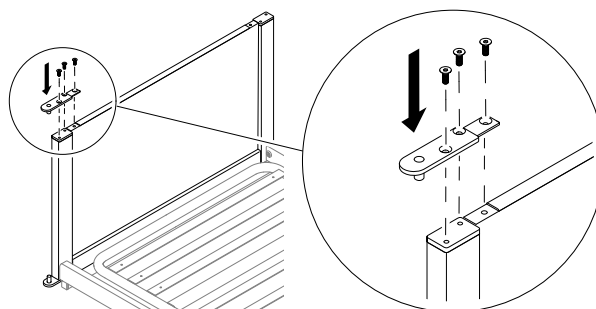

On one side of the bed temporarily install the plate to fix the bed end board to the bed end frame until a side rail has been mounted in the other side of the bed.



This is a temporary solution to hold the bed end board in place. As soon as side rail has been installed on the other side of the bed this plate can be removed again for the installation of the second side rail.

7. Repeat steps 1 to 4 on the other end of the bed.

3.3 Installing side rails



WARNING!

Risk of personal damage

There is a risk of entrapment or squeezing, while assembling or disassembling the side rail.

- Pay attention to your fingers.
- Follow instructions carefully.
- After each assembly, check that all fittings are properly tightened and that the side rail has the correct function.

3.3.1 Installing the Fixed Side Rail



Allen key (4 mm)

Mounting

1.

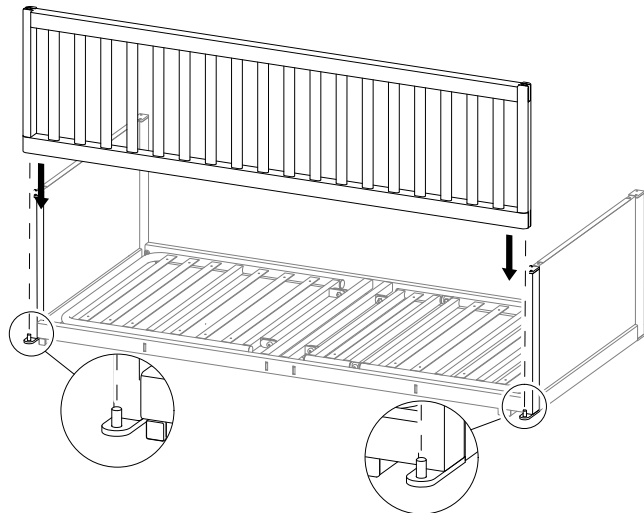

Place the side rail onto the pins on the bed end frames.



If the side rail does not fit onto the pins, an adjustment of the bed ends is required. See 3.4 *Adjusting Bed Ends*, page 8

2.

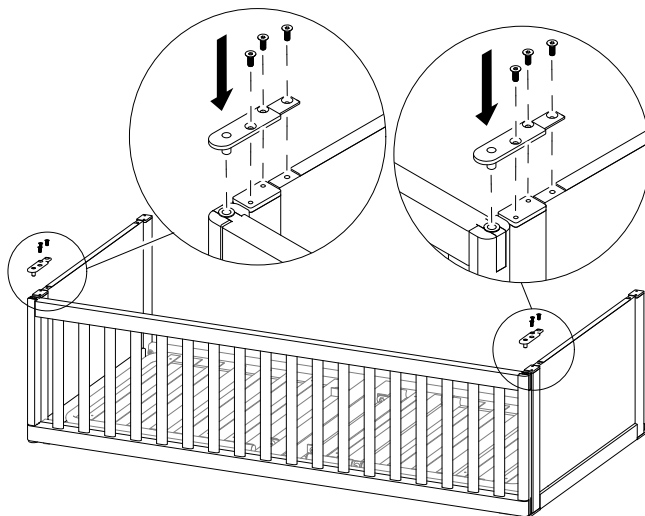

On both ends of the bed, fix the side rail and bed end boards with the plate and the three screws.

3. Check the side rail for proper fitting and adjust the bed ends if required. See 3.4 *Adjusting Bed Ends*, page 8

Dismounting

Follow step 1 and 2 for mounting in reversed order.

3.3.2 Installing the Lowering Side Rail



Allen key (4 mm)

Mounting

1.

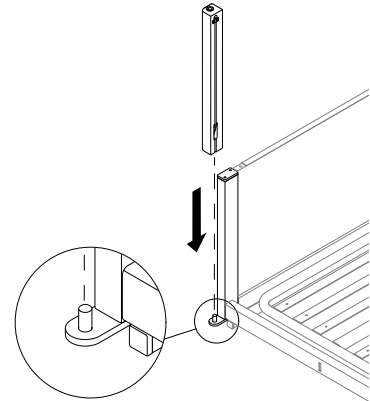

Place the pillar onto the pin on the bed end frames with the guideway facing towards the other end of the bed.

2.

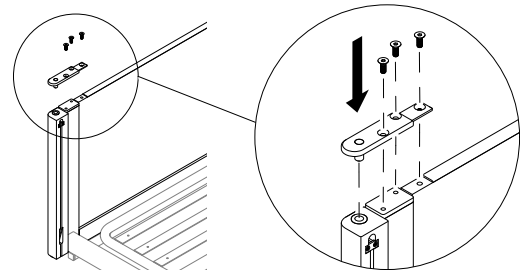

Fix the pillar and bed end board with the plate and the three screws.

3. Repeat step 1 and 2 on the other end of the bed.

4. Raise the bed to the highest position.

5.

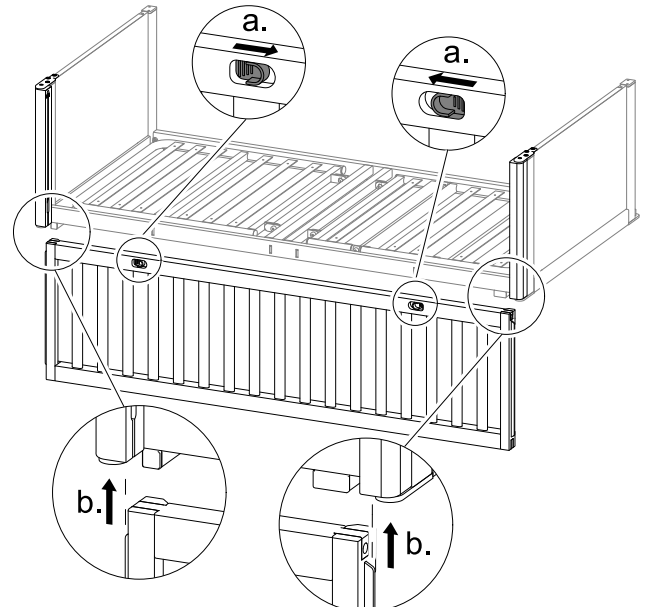

Push and hold the two latches towards each other and slide the side rail into the guideways of the pillars from below.

6. Check the side rail for proper fitting and function and adjust the bed ends if required. See 3.4 *Adjusting Bed Ends*, page 8

Dismounting

Raise the bed to its highest position and follow step 1, 2 and 5 for mounting in reversed order on both ends of the bed.

3.3.3 Installing the Side Rail with Foldable Doors

 Allen key (2.5 mm, 4 mm)

- !** **NOTICE!**
- The side rail must be mounted and dismounted in its locked folded state.
 - The four small wedges and the center wedge must always be mounted on the same side of the bed as the side rail with foldable doors.

Mounting

1.

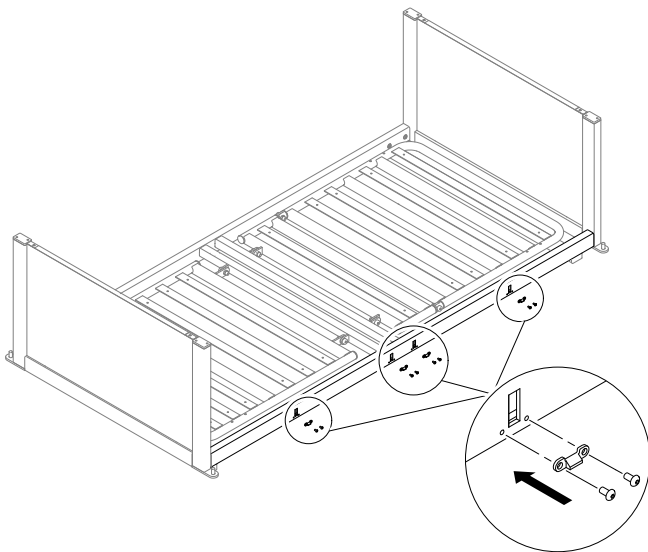

Fix a small wedge with two screws below each of the four slots on the lateral square tube of the mattress support platform.

2.

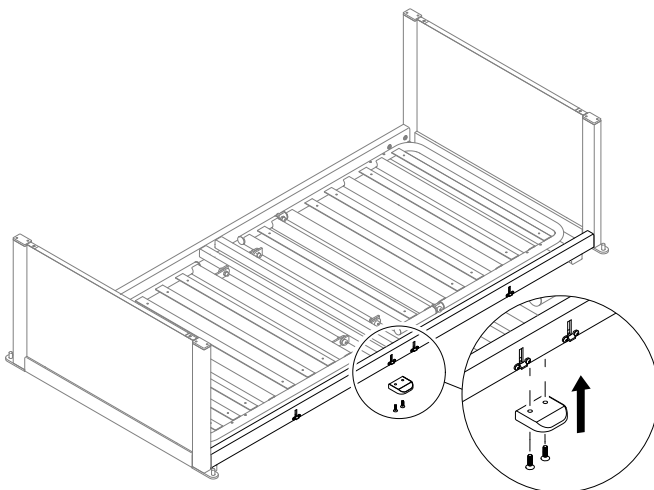

Fix the center wedge with two screws to the underside of lateral square tube of the mattress support platform.

3.

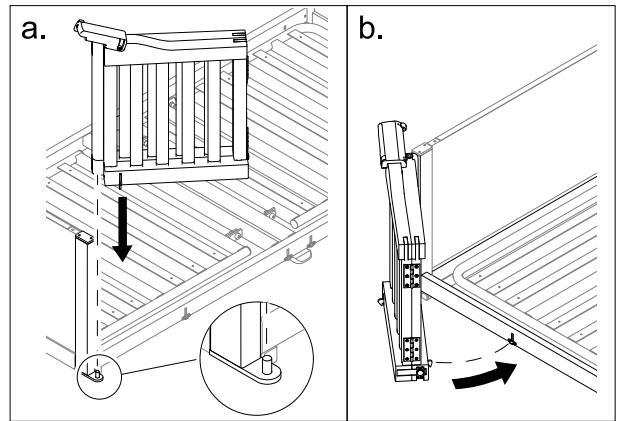

Place the side rail onto the pin on the bed end frame and close it, so it engages to the lateral square tube of the mattress support platform with an audible click.

4.

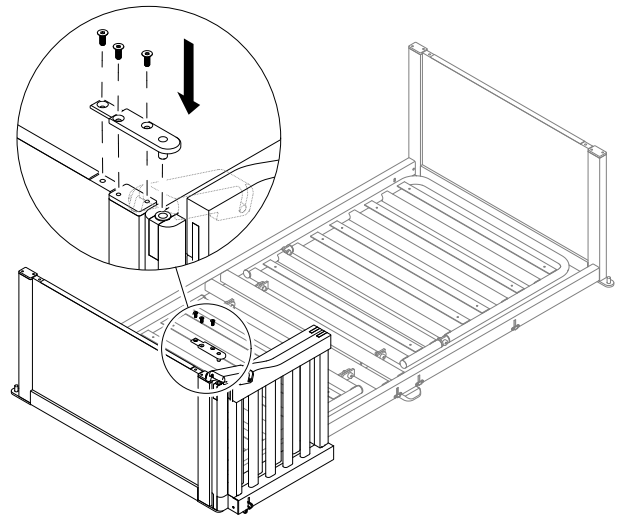

Fix the side rail and bed end boards with the plate and the three screws.

- Repeat step 3 and 4 on the other end of the bed.
- Check the side rail for proper fitting and function and adjust the bed ends if required. See [3.4 Adjusting Bed Ends, page 8](#)

Dismounting

Follow step 1 to 4 for mounting in reversed order on both ends of the bed.

3.4 Adjusting Bed Ends

 Allen key (3 mm, 4 mm)

During the installation of the side rails it might be required to adjust the angle between the bed end frame and the mattress support platform for proper fitting and function of the side rails.

1.

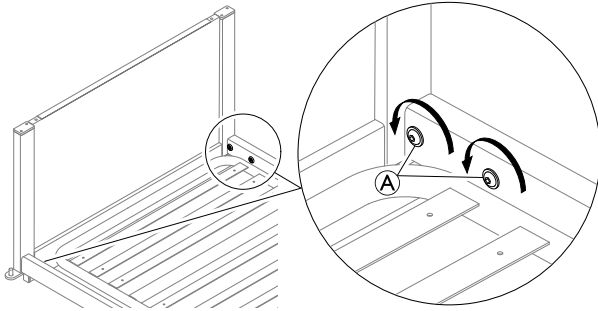

Slightly loosen screws **A** in each corner so the bed end frames are still stable but slightly adjustable in angle.

2.

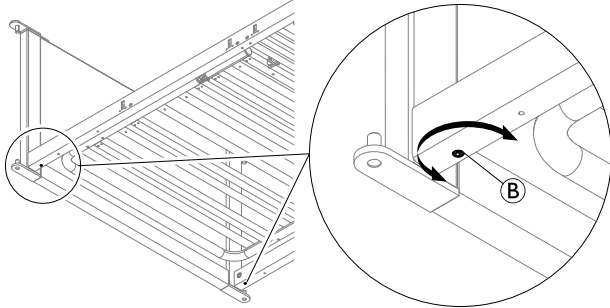

If required use the grub screws **B** to adjust the angle of the bed end frames until the side rails fit and function properly.

3.

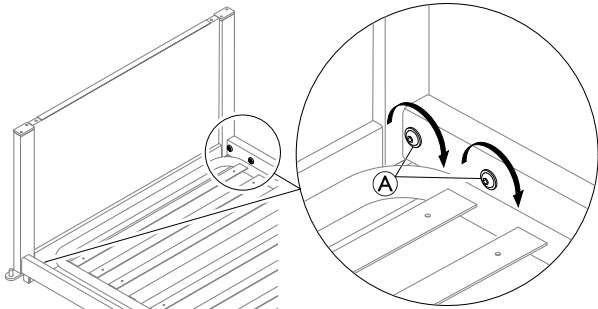

Completely tighten screws **A** in each corner of the bed.

4 Transportation and Storage

4.1 Dismounting the Mattress Support Platform

! NOTICE!
 Before dismounting
 – Ensure the brakes are engaged.
 – At least two persons are needed to dismount the mattress support platform as it must be supported in both ends.

1. Raise the bed to its highest position and unplug the bed from the mains.
- 2.

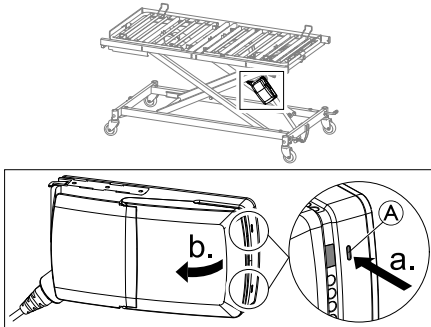

Press in the two latches **A** on the control unit with a pointed object (e.g. screwdriver) and open the lid.

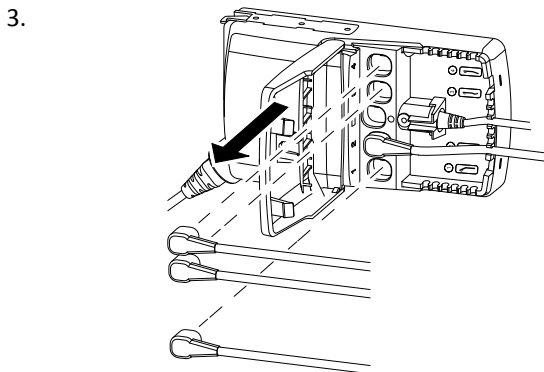

Unplug the cables of the mattress sections actuators from the control unit and close the lid of the control unit.

i The number of actuator cables to unplug depends on the configuration of the bed. Do not unplug the cable of the height adjustment actuator and the hand control. See 5.4 Control Unit, page 13.

4. Connect the bed to the mains and lower it to its lowest position.

5.

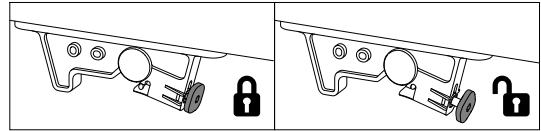
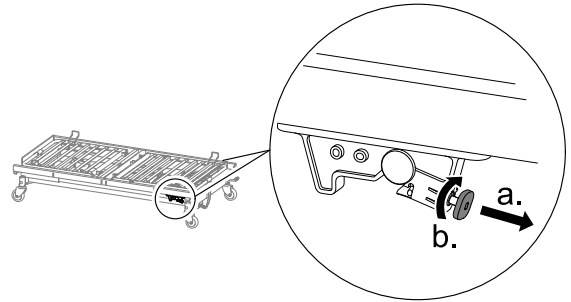

On both sides of the mattress support platform pull the red locking pin and turn it 45° clockwise to engage it in the unlocked position.

6.

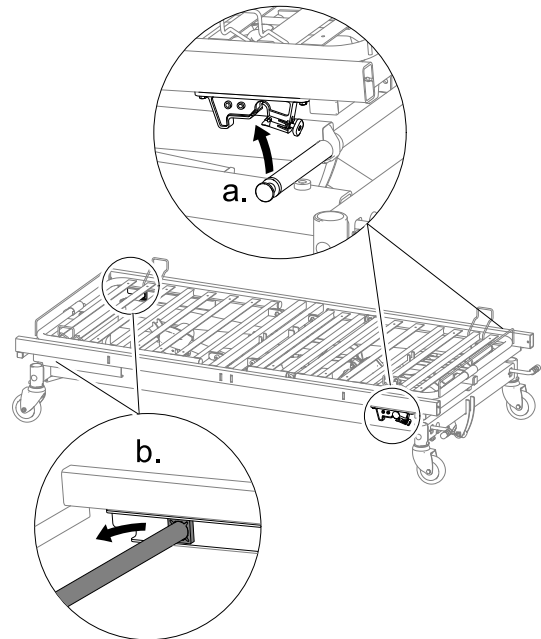

- a. In the foot end, lift the mattress support platform off the lifting mechanism.
- b. In the head end, slide the lifting mechanism gliding blocks out of the guideways on the mattress support platform.

7.

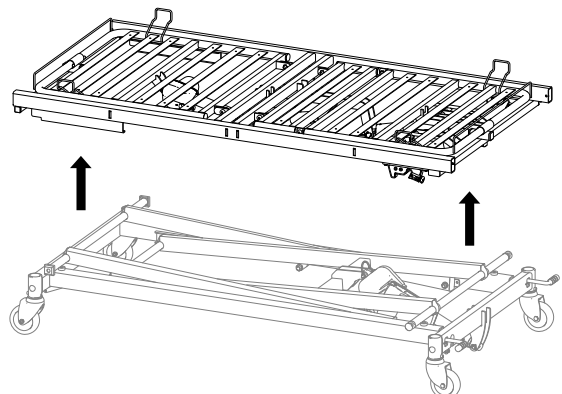

Lift the mattress support platform off the base.

4.2 Mounting the Mattress Support Platform

! **NOTICE!**
 Before mounting
 – Ensure the brakes are engaged.
 – At least two persons are needed to mount the mattress support platform as it must be supported in both ends.

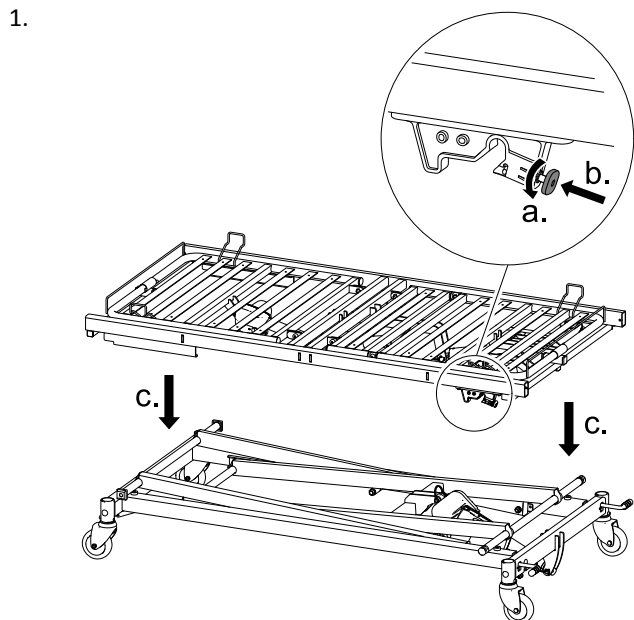

On both sides of the mattress support platform turn the red locking pin by 45° counter-clockwise and let it engage in its locked position before lowering the mattress support platform onto the lifting mechanism.

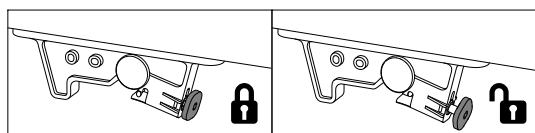
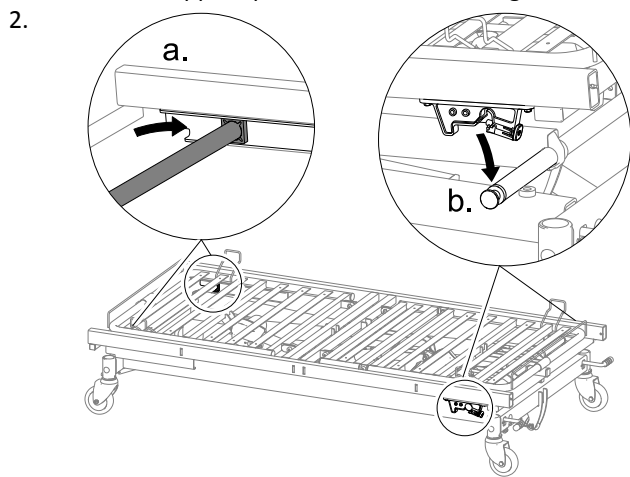

In the head end, slide the lifting mechanism gliding blocks into the guideways on the mattress support platform and in the foot end lower the mattress support platform onto the lifting mechanism until it engages with an audible click.

3. Connect the bed to the mains, raise it to the highest position and unplug the bed from the mains again.

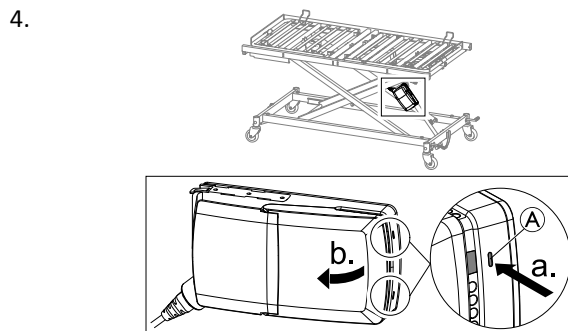

Press in the two latches (A) on the control unit with a pointed object (e.g. screwdriver) and open the lid.

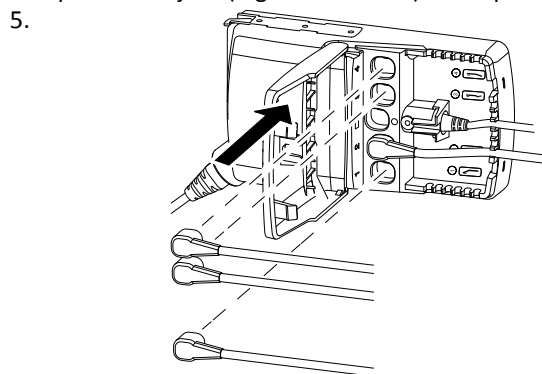

Plug in the cables of the mattress section actuators and close the lid of the control unit.

i The number of actuator cables to plug in depends on the configuration of the bed. See 5.4 Control Unit, page 13.

5 Servicing

5.1 General servicing information



NOTICE!

- The mattress support must be supported during service inspections, to prevent accidental lowering.
- Only personnel who have received the necessary instructions or training may perform service and maintenance of the bed.
- After reconditioning the bed, or if bed functions change, service must be carried out according to the check list.

A service contract can be made in the countries, where Invacare has its own sales company. In certain countries Invacare offers courses in service and maintenance of the bed. Spare parts lists and additional user manuals are available from Invacare.

Before Use

- Ensure that all manual and electrical parts functions correctly and are in a secure state.
- Check, by raising and lowering the bed, that the shear arms run smoothly in the guideways.

After three months

- Ensure that all manual and electrical parts are functioning, and tighten bolts, screws, nuts, etc.

Every year

- We recommend a safety test comprising the actuators' performance and mechanical state.

Every second year

- We strongly recommend a service according to the below checklist after two years of normal use and then every second year.



Actuators, hand control and control unit are serviced by exchanging the faulty part.

5.1.1 Checklist - Maintenance

Checkpoints

- Circlips, cotter pins and plastic fixing ring - properly locked and intact.
- Screws - tightened.
- Weldings - intact.
- Check the guideways - no bending.
- Side rail locking and moving system - properly locking and running smoothly.
- Castor fittings - tightened.
- Castor brakes - locking properly.
- Height adjustment actuators - running properly.
- Mattress support section actuators - running properly.
- Cables - correctly wired and undamaged.
- Electric plugs - undamaged.
- Cable insulation and actuator housings – no cracks or damages.

- Damaged coating - repaired.
- Accessories - correctly assembled and correct function.

5.2 Inspection after relocation - Prepare for new user



NOTICE!

- When the bed has been relocated; before given to a new user it has to be thoroughly inspected.
- Inspection must be done by a trained professional.
 - For regular maintenance see maintenance chart.

5.2.1 Checklist - After relocation

Checkpoints

- Check that the lifting mechanism is properly engaged in the lower pivoting points and guideways on the base.
- Check that the latches, locking the mattress support on the shear arms, are properly engaged (red button on the mattress support).
- Check the locking of the actuators (pipe pins correctly mounted).
- Check the electronic wiring for the actuators (cables not squeezed).
- Check that the enclosing of the actuators are intact (no cracks that enables fluids to pierce).
- Check that all cables are properly mounted on the control unit.
- Check the sections of the mattress support by using the hand control to activate all functions of the moving parts.
- Check the function of the brakes.
- Check that the bed end attachments are properly mounted (steady) and that the bed ends are securely attached.
- Check the locking function(s) of the side rails.

5.3 Cleaning and Disinfection

5.3.1 General safety information



CAUTION!

Risk of contamination

- Take precautions for yourself and use appropriate protective equipment.



CAUTION!

Risk of electric shock and product damage

- Switch off the device and disconnect from mains, if applicable.
- When cleaning electronic components consider their protection class regarding water ingress.
- Make sure that no water splashes to the plug or the wall outlet.
- Do not touch the power socket with wet hands.

! NOTICE!
 Wrong fluids or methods can harm or damage the product.

- All cleaning agents and disinfectants used must be effective, compatible with one another and must protect the materials they are used to clean.
- Never use corrosive fluids (alkalines, acid etc.) or abrasive cleaning agents. We recommend an ordinary household cleaning agent such as dishwashing liquid, if not specified otherwise in the cleaning instructions.
- Never use a solvent (cellulose thinner, acetone etc.) that changes the structure of the plastic or dissolves the attached labels.
- Always make sure that the product is completely dried before taking into use again.

i For cleaning and disinfection in clinical or long-term care environments, follow your in-house procedures.

5.3.2 Cleaning Intervals

! NOTICE!
 Regular cleaning and disinfection enhance smooth operation, increases the service life and prevents contamination.
 Clean and disinfect the product:

- regularly while in use,
- before and after any service procedure,
- when it has been in contact with any body fluids,
- before using it for a new user.

5.3.3 Cleaning Instructions

! NOTICE!
 – The product does not tolerate cleaning in automatic washing systems, with high-pressure cleaning equipment or steam.

Cleaning by Hand

All components (excluding removable textiles)

- Cleaning agent: We recommend using a mild detergent with neutral or near neutral pH (5-9).
- i** Commercially available consumer products like hand dishwashing liquid or all-purpose cleaners can be used. Read the instructions on the label of your cleaning agent and use it at the indicated concentration.
- Max. water temperature: 40 °C
1. Wipe surfaces thoroughly with a soft cloth slightly moistened with detergent solution until all visible soil is removed.
 2. Remove all detergent residue with a clean damp cloth.
 3. Wipe dry using a clean soft cloth.

Removable textiles (including upholstery and mattresses)

- See attached label on each product.

5.3.4 Disinfection Instructions

In Domestic Care

- Disinfectant: We recommend using an alcohol-based surface disinfectant (with 70-90% alcohol).

i Read the instructions on the label of your disinfectant. It provides information on the activity spectrum (bacteria, fungi and/or viruses), material compatibility and the correct exposure time.

1. Ensure the surfaces are cleaned before disinfection.
2. Moisten a soft cloth and wipe-disinfect all accessible surfaces and keep them moistened for the exposure time stated on the label of the disinfectant.
3. Allow the product to air-dry.

In Institutional Care

Follow your in-house disinfection procedures and only use the disinfectants and methods specified therein.

5.3.5 Lubrication

We recommend lubricating the bed according to the following table:

Part of bed	Lubrication method
Bearings for lifting- and shear arms	Oil (medically clean)
Motor suspension	Oil (medically clean)
Gliders and guideways	Grease
Axles and rolls for shear arm (axle must be dismounted)	Grease

i For ordering of correct oil and grease, please contact your Invacare dealer.

5.4 Control Unit

The control unit is attached to the height adjustment actuator and is most conveniently accessed with the bed in its highest position.

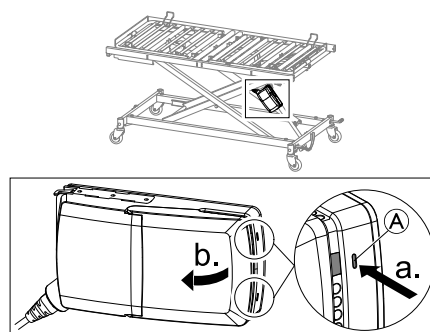

To open the control unit:
 Press in the two latches **A** on the control unit with a pointed object (e.g. screwdriver) and open the lid.

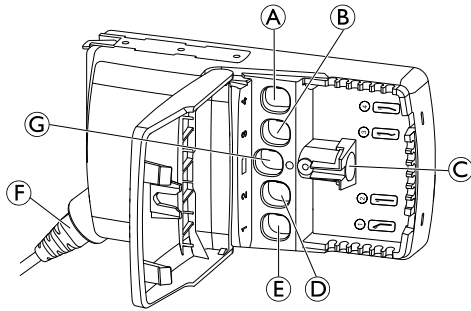

- Ⓓ Height adjustment actuator
- Ⓔ Back section actuator
- Ⓕ Mains power cable
- Ⓖ not used

The actuator sockets inside the control unit are labeled with symbols and colors, indicating where to connect the respective plugs.

- Ⓐ Leg section actuator
- Ⓑ Tight section actuator
- Ⓒ Hand control

5.4.1 Resetting the control unit

i In case of fatal error on control unit, the orange light turns on and a buzzing sound is heard on the control unit when a button is pressed, and the bed does not move. To clear this error, the bed must be reset.

1. To reset the bed, press Hi-Lo up and Hi-Lo down (second line of the hand control) simultaneously for 5 seconds. After that, the orange light changes to green.

**Ireland:**

Invacare Ireland Ltd,
Unit 5 Seatown Business Campus
Seatown Road, Swords, County Dublin
EirCode: K67 K271 — Ireland
Tel : (353) 1 810 7084
Fax: (353) 1 810 7085
ordersireland@invacare.com
www.invacare.ie

United Kingdom:

Invacare Limited
Pencoed Technology Park, Pencoed
Bridgend CF35 5AQ
Tel: (44) (0) 1656 776 200
uk@invacare.com
www.invacare.co.uk



Invacare Rea AB
Växjövägen 303
SE-343 71 Diö
Sweden

