

Küschall® Champion



en Active wheelchair
Service Manual



PROVIDER: Keep this manual.
The procedures in this manual MUST be performed by a qualified technician.

Küschall®
UNLIMIT YOUR WORLD

© 2019 Invacare Corporation

All rights reserved. Republication, duplication or modification in whole or in part is prohibited without prior written permission from Invacare. Trademarks are identified by ™ and ®. All trademarks are owned by or licensed to Invacare Corporation or its subsidiaries unless otherwise noted.

Contents

| | |
|--|-----------|
| 1 General | 4 |
| 1.1 Introduction | 4 |
| 1.2 Symbols in This Manual | 4 |
| 2 Safety | 5 |
| 2.1 General Safety Information | 5 |
| 2.2 Personal safety information | 5 |
| 2.3 General repair information | 5 |
| 3 Product Overview | 7 |
| 3.1 Main parts of the wheelchair | 7 |
| 3.2 Dimensions | 7 |
| 4 Servicing | 8 |
| 4.1 Inspection checklist | 8 |
| 4.2 Spare parts | 8 |
| 5 Reconditioning | 9 |
| 5.1 Cleaning | 9 |
| 5.2 Disinfection | 9 |
| 5.3 Materials | 9 |
| 5.4 Reconditioning scheme | 10 |
| 6 Instructions | 11 |
| 6.1 Frame overview | 12 |
| 6.1.1 Replacing the frame | 12 |
| 6.1.2 Replacing the folding front frame (SK option) | 12 |
| 6.2 Seat | 13 |
| 6.2.1 Adjusting the front seat-to-floor height (FSTF) | 13 |
| 6.2.2 Adjusting the rear seat-to-floor height (RSTF) | 17 |
| 6.2.3 Replacing the seat cover | 17 |
| 6.3 Adjusting the folding mechanism | 18 |
| 6.4 Backrest | 19 |
| 6.4.1 Tension adjustable backrest | 19 |
| 6.4.2 Backrest height (BH) | 21 |
| 6.4.3 Backrest angle (BA) | 22 |
| 6.4.4 Push handles / telescopic tubes | 22 |
| 6.4.5 Installing the stabilisation bar | 25 |
| 6.5 Footrests | 26 |
| 6.5.1 Replacing the footrest | 27 |
| 6.5.2 Replacing the foot plate | 27 |
| 6.5.3 Turning the foot plate | 27 |
| 6.5.4 Adjusting the foot plate angle | 28 |
| 6.6 Sideparts | 29 |
| 6.6.1 Installing the clothes-guard | 29 |
| 6.6.2 Installing the mudguard | 31 |
| 6.6.3 Installing/adjusting the siderest | 32 |
| 6.6.4 Installing the tubular armrest | 32 |
| 6.7 Castors | 33 |
| 6.7.1 Replacing the castor wheel | 33 |
| 6.7.2 Replacing the castor fork | 33 |
| 6.7.3 Checking and adjusting the castor angle | 34 |
| 6.7.4 Checking and adjusting the drift angle | 34 |
| 6.7.5 Installing/shifting the castor fork supporter on the frame | 35 |
| 6.8 Rear wheels | 35 |
| 6.8.1 Repositioning the rear wheels | 35 |
| 6.8.2 Wheel camber, adapter sleeves | 35 |
| 6.8.3 Adjusting the removable axle | 36 |
| 6.8.4 Installing distance sleeves for rear wheels | 36 |
| 6.8.5 Adapter plate — Adjusting the folding unit / Installing the adapter plate | 36 |
| 6.8.6 Repairing or changing an inner tube | 37 |
| 6.8.7 Replacing a solid tire | 37 |
| 6.8.8 Replacing rear wheel spokes | 37 |
| 6.9 Parking brakes | 38 |
| 6.9.1 Installing the parking brake | 38 |
| 6.9.2 Adjusting the parking brake | 38 |
| 6.10 Options and Accessories | 39 |
| 6.10.1 Installing the antitipper | 39 |
| 6.10.2 Installing the tipper aid and/or cane holder | 40 |
| 6.10.3 Installing the posture belt | 41 |
| 6.10.4 Installing the positioning belt | 41 |

1 General

1.1 Introduction

This document contains important information about assembly, adjustment and advanced maintenance of the product. To ensure safety when handling the product, read this document and the user manual carefully and follow the safety instructions.

Find the user manual on Invacare's website or contact your Invacare representative. See addresses at the end of this document.

Invacare reserves the right to alter product specifications without further notice.

Before reading this document, make sure you have the latest version. You find the latest version as a PDF on the Invacare website.

For pre-sale and user information, see the user manual.

For more information about the product, for example product safety notices and product recalls, contact your Invacare representative. See addresses at the end of this document.

1.2 Symbols in This Manual

Symbols and signal words are used in this manual and apply to hazards or unsafe practices which could result in personal injury or property damage. See the information below for definitions of the signal words.

**WARNING**

Indicates a hazardous situation that could result in serious injury or death if it is not avoided.

**CAUTION**

Indicates a hazardous situation that could result in minor or slight injury if it is not avoided.

**IMPORTANT**

Indicates a hazardous situation that could result in damage to property if it is not avoided.

**Tips**

Gives useful tips, recommendations and information for efficient, trouble-free use.

**Tools**

Identifies required tools, components and items which are needed to carry out certain work.

2 Safety

2.1 General Safety Information



WARNING!

Risk of injury or damage to property

- The procedures in this manual must only be performed by a qualified technician.
- Use only original accessories and spare parts.
- Do not handle this product or any available optional equipment without first completely reading and understanding these instructions and any additional instructional material such as user manuals, installation manuals or instruction sheets supplied with this product or optional equipment.
- After each assembly, check that all fittings are properly tightened and that all parts have the correct function.



WARNING!

Risk of contamination

- Clean and disinfect the product before servicing.



IMPORTANT!

- Assembly of accessories might not be described in this service manual. Refer to the manual, delivered with the accessory.
 - Additional manuals can be ordered from Invacare. See addresses at the end of this document.
 - Due to regional differences, refer to your local Invacare catalog or website for available accessories or contact your local Invacare representative. See addresses at the end of this document.



IMPORTANT!

- Some replacement parts are only available as a kit. Always use the complete new kit when replacing a part.
 - Spare parts can be ordered from Invacare. Refer to your local Invacare website to access the electronic spare parts catalogue (ESPC).



IMPORTANT!

- Refer to the user manual of this product for information on
 - Technical data
 - Product components
 - Labels
 - Additional safety instructions



The information contained in this document is subject to change without notice.

2.2 Personal safety information

These safety instructions are intended to help avoid accidents during work and must be observed under all circumstances.

All employees coming into contact with contaminated products must regularly consult a company doctor. Work clothing and personal protective equipment must be available in necessary quantities and be in proper condition. Reliable hand and surface disinfection must be ensured.



WARNING!

Risk of contamination

- Clean and disinfect the product before carrying out repairs.

2.3 General repair information

Repairs require a high level of expertise. These assembly instructions therefore break down the various tasks into 3 categories:

| Requirement | Symbol |
|--|--------|
| Easy – technical understanding required | ■□□ |
| Medium – technical knowledge required | ■■□ |
| Difficult – technical knowledge and expertise in assembling required | ■■■ |

The required tools and their sizes are listed before the instructions.

- !** **IMPORTANT!**
- If possible, continue to use the old identification label; if this is not possible, the new identification label must contain the same information and the old serial number. (Replacement of spare parts with serial numbers).
 - When components are replaced it is necessary to ensure the traceability of the components replaced.
 - If screws with thread locker are loosened, these must be replaced with new screws with thread locker. Alternatively, new thread locker must be applied.
 - If screws with circlip rings are loosened, these must be replaced with new ones.
 - Parts that become damaged during removal must be replaced with new ones.
 - All bolts must be tightened with the torque specified in the following instructions.

Fastening with hexagon socket bolts

Hexagon socket bolts are not designed to withstand an excessive application of force. When tightening or undoing a hexagon socket bolt, force should be applied to the nut wherever possible to avoid damaging the bolt.

Tightening and undoing

Turn the nut using a socket spanner (only use an open-end spanner if there is insufficient space), using the Allen key simply to stop the bolt turning.

Tightening and undoing when no nut is present

If a hexagon socket bolt is screwed directly into a thread, the bolt must be tightened using the Allen key.

Ensure that the Allen key is of good quality and not worn.

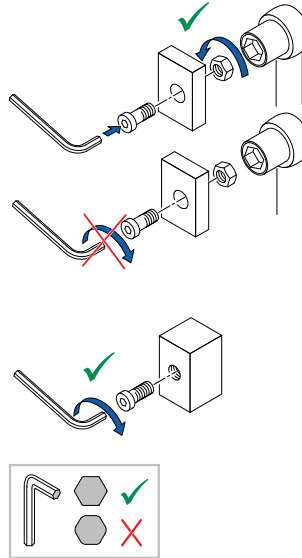

3 Product Overview

3.1 Main parts of the wheelchair

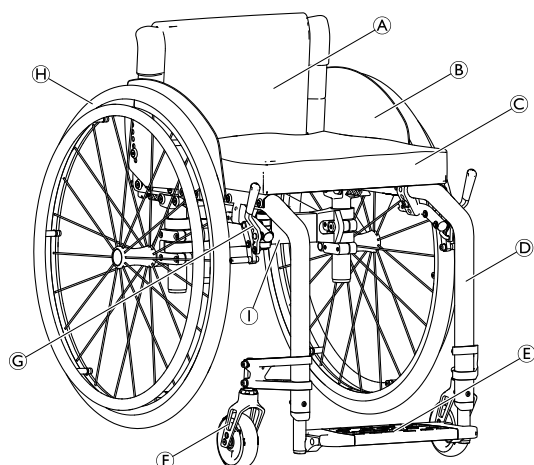

- Ⓐ Backrest
- Ⓑ Clothes-guard
- Ⓒ Seat with cushion
- Ⓓ Frame
- Ⓔ Footrest
- Ⓕ Castor fork with castor wheel
- Ⓖ Parking brake
- Ⓗ Rear wheel with handrim and quick-release axle
- Ⓘ Folding mechanism

3.2 Dimensions

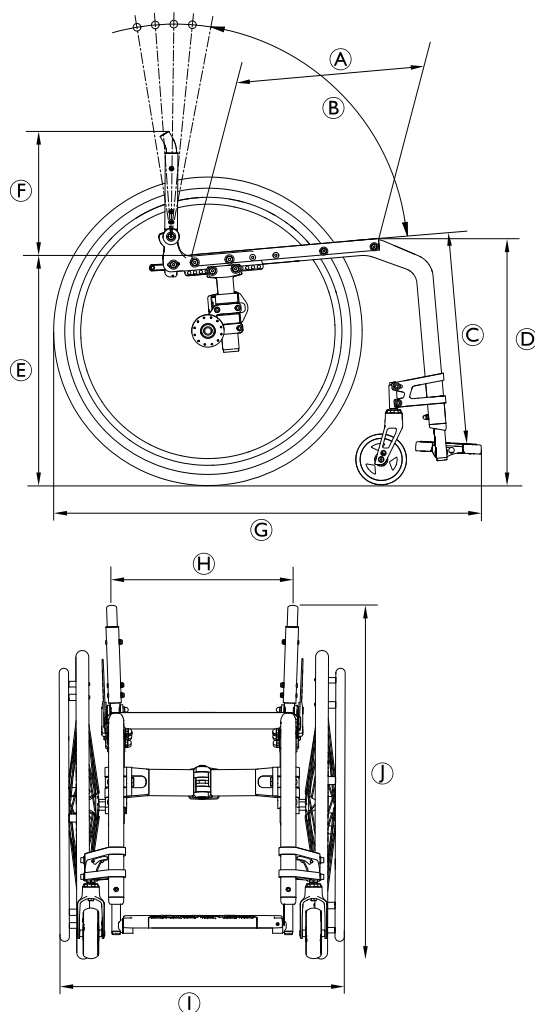

| | | |
|---|-----------------------------------|--|
| Ⓐ | Seat depth (SD) | 340 – 480 mm, in increments of 20 mm |
| Ⓑ | Backrest angle (BA) | 76°/80,5°/85°/89,5°/94° |
| Ⓒ | Lower leg length (LLL) | 320 – 500 mm, in increments of 10 mm |
| Ⓓ | Front seat-to-floor height (FSTF) | 450 – 540 mm, stepless adjustable |
| Ⓔ | Rear seat-to-floor height (RSTF) | 390 – 490 mm, stepless adjustable |
| Ⓕ | Backrest height (BH) | 300 – 465 mm, in increments of 15 mm |
| Ⓖ | Total length (TL) | 75°: approx. 825 – 1190 mm 90°: approx. 775 – 1140 mm |
| Ⓗ | Seat width (SW) | 360 – 480 mm, in increments of 20 mm |
| Ⓘ | Total width (TW) | Seat width plus 160 – 240 mm |
| | Total width, folded | approx. 280 – 340 mm |
| Ⓙ | Total height (TH) | 690 – 955 mm |

4 Servicing

4.1 Inspection checklist

| | | |
|--|--------------------------|--------------------------|
| General inspection | ☺ | ☹ |
| Is the product in good condition and is it complete (product and accessories)? | <input type="checkbox"/> | <input type="checkbox"/> |
| Is the product free from damage or weaknesses of any kind? | <input type="checkbox"/> | <input type="checkbox"/> |
| Does the product operate correctly under nominal load? | <input type="checkbox"/> | <input type="checkbox"/> |
| Is the product fully functional in accordance with the user manual? | <input type="checkbox"/> | <input type="checkbox"/> |
| Eradication of faults | ☺ | ☹ |
| Have all the faults found been eliminated and have faulty components been replaced? | <input type="checkbox"/> | <input type="checkbox"/> |
| Are all screws/bolts firmly fitted and is the product securely assembled? | <input type="checkbox"/> | <input type="checkbox"/> |
| Completion of checks | ☺ | ☹ |
| Is the product technically and functionally safe? | <input type="checkbox"/> | <input type="checkbox"/> |
| Has the product been cleaned and disinfected? | <input type="checkbox"/> | <input type="checkbox"/> |
| Is the identification label easily readable and is it securely mounted on the product? | <input type="checkbox"/> | <input type="checkbox"/> |
| Is the product accompanied by the latest revision of the user manual? | <input type="checkbox"/> | <input type="checkbox"/> |

4.2 Spare parts



WARNING!

Original spare parts must be used in all repairs. Otherwise the warranty and product declaration of conformity shall be rendered invalid.

All spare parts must be obtained from the Invacare customer service department. An electronic spare parts catalogue can be found on your local Invacare website.



WARNING!

Risk of injury due to damaged or worn parts

Some replacement parts are only available as a kit.
– Always use the complete new kit when replacing a part.

5 Reconditioning

5.1 Cleaning

IMPORTANT!

– The product does not tolerate cleaning in automatic washing plants, with high-pressure cleaning equipment or steam.

IMPORTANT!

Dirt, sand and seawater can damage the bearings and steel parts can rust if the surface is damaged.
 – Only expose the wheelchair to sand and seawater for short periods and clean it after every trip to the beach.
 – If the wheelchair is dirty, wipe off the dirt as soon as possible with a damp cloth and dry it carefully.

1. Remove any accessories fitted (only accessories which do not require tools).
2. Wipe down the individual parts using a cloth or soft brush, ordinary household cleaning agents (pH = 6 - 8) and warm water.
3. Rinse the parts with warm water.
4. Thoroughly dry the parts with a dry cloth.



Car polish and soft wax can be used on painted metal surfaces to remove abrasions and restore gloss.

Cleaning upholstery

For cleaning upholstery refer to the instructions on the labels of the seat, cushion and backrest cover.

5.2 Disinfection



Information on recommended disinfectants and methods can be found on <https://vah-online.de/en/for-users>.

1. Wipe down all generally accessible surfaces with a soft cloth and ordinary household disinfectant.
2. Allow the product to air-dry.

5.3 Materials

The components used to manufacture Kuschall® wheelchairs consist of following materials:

| | |
|--------------------------------|-------------------------|
| Frame tubes | Aluminum |
| Backrest tubes | Aluminum |
| Folding mechanism | Aluminum |
| Seat cover / Backrest cover | PA / PE / PVC |
| Push handles | Steel / Aluminum / TPE |
| Clothes guard / Mudguard | Carbon Fiber or Plastic |
| Castor forks | Aluminum |
| Legrest | Aluminum |
| Footrest | Carbon Fiber or Plastic |
| Supporting parts / Attachments | Steel / Aluminum |
| Screws and bolts | Steel |

All components have either a protective coating or are corrosion resistant.

5.4 Reconditioning scheme

The following items must be reviewed and checked when reconditioning is required:

| Symptoms | Faults | Solution |
|--|---|--|
| The wheelchair does not travel in a straight line | Incorrect tyre pressure on one rear wheel | Correct tyre pressure, see user manual |
| | One or more spokes broken | Replace broken spoke(s) |
| | Spokes tightened unevenly | Tighten loose spoke(s) |
| | Castor wheel bearings are dirty or damaged | Clean or replace the bearings or the complete castor wheel 6.7.1 <i>Replacing the castor wheel, page 33</i> |
| | Support bearings in forks faulty | Replace the support bearings, see 6.7.2 <i>Replacing the castor fork, page 33</i> |
| | Castor or drift angle, left and right, uneven Bearing block of castor fork is not vertical | Adjust the castor and drift angle, see 6.7.3 <i>Checking and adjusting the castor angle, page 34</i> and 6.7.4 <i>Checking and adjusting the drift angle, page 34</i> |
| | Castor wheels not set to the same height | Position the front wheels in such a way that they touch the ground at the same time, see 6.7.5 <i>Installing/shifting the castor fork supporter on the frame, page 35</i> |
| | Rear wheels not parallel or axles not aligned | Adjust the prestress load on the folding mechanism and/or the trail, see 6.3 <i>Adjusting the folding mechanism, page 18</i> |
| The wheelchair tips too easily | Rear wheels are mounted too far forwards | Mount the rear wheels further back, see 6.8.1 <i>Repositioning the rear wheels, page 35</i> |
| | Backrest angle too large | Reduce backrest angle, see 6.4.3 <i>Backrest angle (BA), page 22</i> |
| | Seat angle too large | Mount the adapter plate lower on the side profile, see 6.8.5 <i>Adapter plate — Adjusting the folding unit / Installing the adapter plate, page 36</i> Install a smaller castor fork, see 6.7.2 <i>Replacing the castor fork, page 33</i> |
| The parking brakes are gripping poorly or asymmetrically | Incorrect tyre pressure in one or both rear tyres | Correct tyre pressure, see user manual |
| | Brake setting incorrect | Correct brake setting, see 6.9.2 <i>Adjusting the parking brake, page 38</i> |
| The rolling resistance is very high | Incorrect tyre pressure in one or both rear wheels | Correct tyre pressure, see user manual |
| | Rear wheels not parallel | Make rear wheels parallel, see 6.8.2 <i>Wheel camber, adapter sleeves, page 35</i> |
| | Bearings are dirty or faulty | Replace the bearings, see 6.7.1 <i>Replacing the castor wheel, page 33</i> |
| The castors wobble when moving fast | Too little tension on the clevis pin housing | Tighten the nut on the castor fork slightly, see 6.7.2 <i>Replacing the castor fork, page 33</i> |
| | Castor wheel is worn out | Replace the castor wheel, see 6.7.1 <i>Replacing the castor wheel, page 33</i> |
| The castor wheel is stiff or stuck | Bearings are dirty or faulty | Replace the bearings, see 6.7.1 <i>Replacing the castor wheel, page 33</i> |
| The wheelchair is very difficult to unfold | The backrest cover is too tight | Loosen the topmost hook and loop band of the backrest cover a little, see user manual |
| Handling seems imprecise | The folding mechanism is not properly closed | Check folding mechanism and remove dirt if necessary |
| | Folding mechanism is misaligned | Realign the folding mechanism, see 6.3 <i>Adjusting the folding mechanism, page 18</i> |

6 Instructions

6.1 Frame overview

The Küschall® Champion frame is made from aluminum. There are frame angles of 75° and 85° available.

6.1.1 Replacing the frame



Allen key (5 mm) / Socket spanner (10)



1. Loosen and remove bolts, nuts and washers (B).
2. Pull the frame (C) out of the side supporters (A).
3. Replace the frame with a new one.
4. Reinsert and tighten bolts, nuts and washers (B).

(B) = 13 Nm

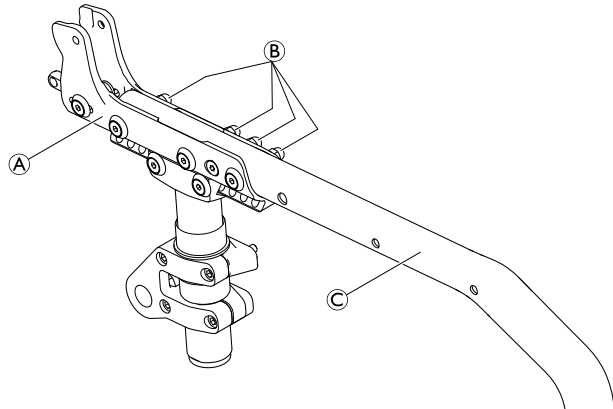

6.1.2 Replacing the folding front frame (SK option)



Allen key (4 mm / 5 mm), mounting grease



1. Lightly grease locking pin (C) and spring (D).
2. Place the spring and locking pin into the inner hole of the lower frame joint (A).
3. Press the locking pin against the spring and align the hole of locking pin with the oblong hole of the lower frame joint.
4. Mount the press button (F) using screw (J) through the oblong hole into the thread of the locking pin.
 - IMPORTANT!**
 - Make sure that the press button is mounted into the oblong hole free of play and also movable against the spring.
5. Lightly grease the joint axle (E).
6. Align the hole of the lower frame joint (A) with the hole of the upper frame joint (B), insert the axle joint and screw both parts together using screws (H) and washers (I). Tighten as much as possible without limiting movement between (A) and (B).

IMPORTANT!

– Make sure that the assembly is free of play and also axially movable without effort.

IMPORTANT!

Risk of damage to the assembly part

The assembly hole for the grub screw (G) in the lower frame joint is slightly angled upwards.

– Observe the correct angle of the assembly hole thread while screwing in the grub screw.

7. Push down button (F) against the spring and screw the grub screw (G) into the adjustment hole of the lower frame joint.
8. Adjust the grub screw to the position that the frame joint engages securely and has no play.
9. Carry out the same settings on both sides.

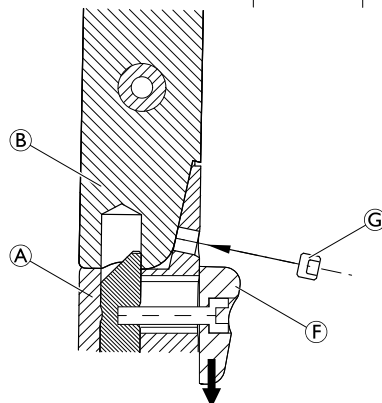
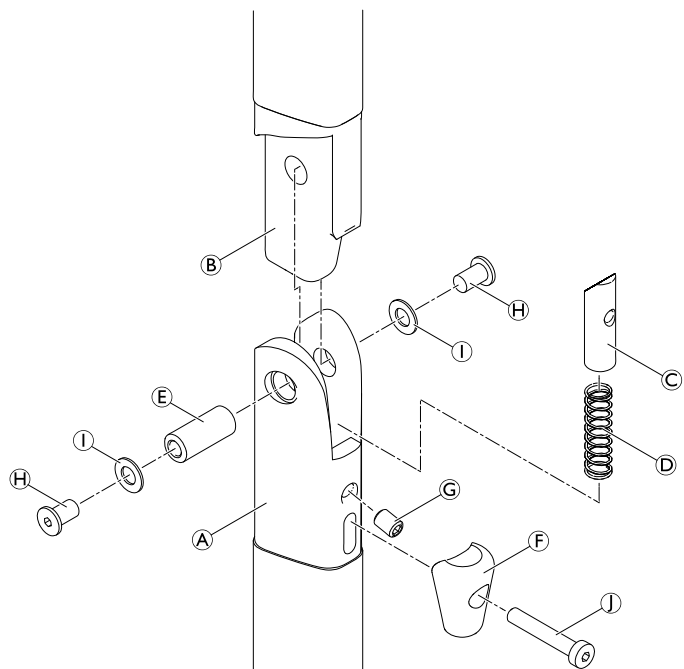



6.2 Seat

6.2.1 Adjusting the front seat-to-floor height (FSTF)

The following possibilities are available to adjust the front seat-to-floor height (FSTF):

- Replace the castor wheel with a larger or smaller one, see chapter 6.7.1 *Replacing the castor wheel, page 33.*
- Replace the castor fork with a larger or smaller one, see chapter 6.7.2 *Replacing the castor fork, page 33.*
- Move the side support on the frame, see chapter 6.8.1 *Repositioning the rear wheels, page 35.*

 Adjusting the front seat height changes the seat angle. It may be necessary to adjust the rear seat height correspondingly.

 Ensure that the rear wheels are parallel after changing the front seat height. If required, they must be readjusted, see chapter 6.8.2 *Wheel camber, adapter sleeves, page 35.*

After adjusting the front seat height the verticality of the castor pins needs to be checked and adjusted, if necessary. See 6.7.4 *Checking and adjusting the drift angle, page 34.*

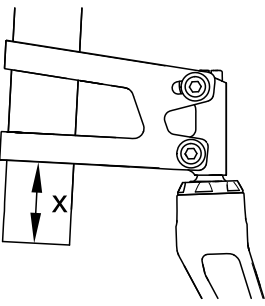
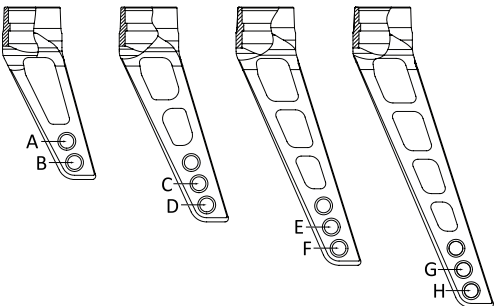
| | |
|--|--|
|  |  |
| <p>x [mm]: Distance from castor supporter to the end of the frame tube. See the following table.</p> | <p>Four castor forks available with mounting positions A – H. See the following table.</p> |

Front seat height (FSTF) per frame type, castor fork and castor wheels

| Frame type | | Frame 75° long | | | | | | Frame 75° short | | | | | |
|----------------------|-----------|--|--------|--------|-----------|--------|--------|--------------------------|----|----|-----------|----|--------|
| Seat depth (SD) [mm] | | 340 – 380 ⁽¹⁾ | | | 400 – 480 | | | 340 – 380 ⁽¹⁾ | | | 400 – 480 | | |
| Castor wheel size | | 3" | 4" | 5" | 3" | 4" | 5" | 3" | 4" | 5" | 3" | 4" | 5" |
| FSTF [mm] | RSTF [mm] | Castor fork mounting position (A-H) / Distance from castor supporter to frame tube end (x) | | | | | | | | | | | |
| 540 | 490 | — | — | F / 26 | — | F / 23 | E / 23 | — | — | — | — | — | — |
| 540 | 480 | — | — | G / 33 | — | G / 33 | F / 33 | — | — | — | — | — | — |
| 540 | 470 | — | — | G / 27 | — | G / 30 | F / 30 | — | — | — | — | — | — |
| 530 | 490 | — | F / 29 | E / 29 | F / 24 | E / 24 | D / 24 | — | — | — | — | — | — |
| 530 | 480 | — | F / 23 | E / 23 | G / 34 | F / 34 | E / 34 | — | — | — | — | — | — |
| 530 | 470 | — | G / 30 | F / 31 | G / 30 | F / 30 | E / 30 | — | — | — | — | — | — |
| 530 | 460 | — | G / 26 | F / 25 | G / 27 | F / 28 | E / 28 | — | — | — | — | — | — |
| 520 | 490 | F / 30 | E / 30 | D / 30 | E / 24 | D / 24 | C / 24 | — | — | — | — | — | — |
| 520 | 480 | F / 26 | E / 26 | D / 26 | F / 34 | E / 34 | D / 34 | — | — | — | — | — | — |
| 520 | 470 | G / 34 | F / 34 | E / 34 | F / 31 | E / 31 | D / 31 | — | — | — | — | — | — |
| 520 | 460 | G / 28 | F / 28 | E / 28 | G / 28 | E / 28 | D / 28 | — | — | — | — | — | — |
| 520 | 450 | G / 26 | G / 35 | F / 35 | F / 25 | E / 25 | D / 25 | — | — | — | — | — | — |
| 510 | 490 | E / 32 | D / 32 | C / 32 | D / 23 | C / 23 | B / 23 | — | — | — | — | — | F / 26 |
| 510 | 480 | E / 28 | D / 28 | C / 28 | E / 34 | D / 34 | C / 34 | — | — | — | — | — | F / 24 |
| 510 | 470 | E / 23 | D / 23 | C / 23 | E / 31 | D / 31 | C / 31 | — | — | — | — | — | G / 35 |
| 510 | 460 | F / 32 | E / 32 | D / 32 | E / 28 | D / 28 | C / 28 | — | — | — | — | — | G / 32 |

| Frame type | | Frame 75° long | | | | | | Frame 75° short | | | | | |
|----------------------|-----------|--|--------|--------|-----------|--------|--------|--------------------------|--------|--------|-----------|--------|--------|
| Seat depth (SD) [mm] | | 340 – 380 ⁽¹⁾ | | | 400 – 480 | | | 340 – 380 ⁽¹⁾ | | | 400 – 480 | | |
| Castor wheel size | | 3" | 4" | 5" | 3" | 4" | 5" | 3" | 4" | 5" | 3" | 4" | 5" |
| FSTF [mm] | RSTF [mm] | Castor fork mounting position (A-H) / Distance from castor supporter to frame tube end (x) | | | | | | | | | | | |
| 510 | 450 | F / 26 | E / 26 | D / 26 | E / 26 | D / 26 | C / 26 | — | — | — | — | — | G / 30 |
| 510 | 440 | G / 33 | F / 33 | E / 33 | F / 35 | E / 35 | D / 35 | — | — | — | — | — | G / 26 |
| 500 | 490 | D / 34 | C / 34 | B / 34 | C / 23 | B / 23 | B / 37 | — | — | E / 23 | — | F / 25 | E / 25 |
| 500 | 480 | D / 30 | C / 30 | B / 30 | D / 34 | C / 34 | B / 35 | — | — | F / 33 | — | F / 23 | E / 23 |
| 500 | 470 | D / 26 | C / 26 | B / 26 | D / 31 | C / 31 | B / 32 | — | — | F / 29 | — | G / 34 | F / 34 |
| 500 | 460 | E / 33 | D / 33 | C / 33 | D / 28 | C / 28 | B / 29 | — | — | F / 25 | — | G / 32 | F / 32 |
| 500 | 450 | E / 29 | D / 29 | C / 29 | D / 26 | C / 26 | B / 26 | — | — | G / 33 | — | G / 30 | F / 30 |
| 500 | 440 | E / 23 | D / 23 | C / 23 | D / 23 | C / 23 | B / 23 | — | — | G / 28 | — | G / 28 | F / 28 |
| 500 | 430 | F / 31 | E / 31 | D / 31 | E / 33 | D / 33 | C / 33 | — | — | G / 26 | — | G / 26 | F / 25 |
| 490 | 490 | C / 35 | B / 34 | B / 48 | C / 35 | B / 34 | B / 50 | — | E / 24 | D / 24 | F / 24 | E / 24 | D / 24 |
| 490 | 480 | C / 31 | B / 30 | B / 45 | C / 33 | B / 32 | B / 48 | — | F / 34 | E / 34 | F / 23 | E / 23 | D / 23 |
| 490 | 470 | C / 27 | B / 27 | B / 41 | C / 31 | B / 30 | B / 46 | — | F / 30 | E / 30 | G / 34 | F / 34 | E / 34 |
| 490 | 460 | C / 23 | B / 23 | B / 36 | C / 29 | B / 28 | B / 43 | — | F / 26 | E / 26 | G / 32 | F / 32 | E / 32 |
| 490 | 450 | D / 31 | C / 31 | B / 31 | C / 27 | B / 27 | B / 40 | — | G / 35 | F / 35 | G / 30 | F / 30 | E / 30 |
| 490 | 440 | D / 26 | C / 26 | B / 26 | C / 23 | B / 23 | B / 37 | — | G / 30 | F / 31 | G / 27 | F / 27 | E / 27 |
| 490 | 430 | E / 33 | D / 33 | C / 33 | D / 33 | C / 33 | B / 34 | — | G / 26 | F / 26 | G / 26 | F / 25 | E / 25 |
| 490 | 420 | E / 28 | D / 28 | C / 28 | D / 30 | C / 30 | B / 31 | — | G / 26 | G / 34 | G / 26 | G / 35 | F / 35 |
| 480 | 480 | B / 33 | A / 32 | B / 58 | B / 33 | A / 32 | B / 61 | F / 34 | E / 34 | D / 34 | F / 34 | E / 34 | D / 34 |
| 480 | 470 | B / 29 | A / 28 | B / 55 | B / 31 | A / 30 | B / 59 | F / 31 | E / 31 | D / 31 | F / 33 | E / 33 | D / 33 |
| 480 | 460 | B / 25 | A / 24 | B / 51 | B / 28 | A / 28 | B / 57 | F / 28 | E / 28 | D / 28 | F / 31 | E / 31 | D / 31 |
| 480 | 450 | C / 33 | B / 32 | B / 47 | B / 27 | A / 26 | B / 54 | F / 24 | E / 24 | D / 24 | F / 29 | E / 29 | D / 29 |
| 480 | 440 | C / 29 | B / 29 | B / 42 | B / 24 | A / 23 | B / 52 | G / 32 | F / 32 | E / 32 | F / 27 | E / 27 | D / 27 |
| 480 | 430 | C / 23 | B / 23 | B / 37 | C / 35 | B / 33 | B / 49 | G / 28 | F / 28 | E / 28 | F / 25 | F / 25 | D / 25 |
| 480 | 420 | D / 31 | C / 31 | B / 31 | C / 32 | B / 29 | B / 45 | G / 26 | F / 23 | E / 23 | G / 35 | F / 35 | E / 35 |
| 480 | 410 | D / 25 | C / 25 | B / 25 | C / 30 | B / 28 | B / 42 | G / 26 | G / 32 | F / 32 | G / 32 | F / 32 | E / 32 |
| 470 | 470 | A / 31 | A / 42 | B / 69 | A / 31 | A / 43 | B / 72 | E / 32 | D / 32 | C / 32 | E / 32 | D / 32 | C / 32 |
| 470 | 460 | A / 26 | A / 38 | B / 65 | A / 29 | A / 41 | B / 70 | E / 28 | D / 28 | C / 28 | E / 30 | D / 30 | C / 30 |
| 470 | 450 | B / 35 | A / 34 | B / 62 | A / 27 | A / 39 | B / 68 | E / 25 | D / 25 | C / 25 | E / 29 | D / 29 | C / 29 |
| 470 | 440 | B / 30 | A / 30 | B / 58 | A / 24 | A / 37 | B / 66 | F / 34 | E / 34 | D / 34 | E / 27 | D / 27 | C / 27 |
| 470 | 430 | B / 26 | A / 25 | B / 53 | B / 34 | A / 34 | B / 63 | F / 30 | E / 30 | D / 30 | E / 25 | D / 25 | C / 25 |
| 470 | 420 | C / 34 | B / 33 | B / 48 | B / 31 | A / 31 | B / 60 | F / 25 | E / 25 | D / 25 | F / 35 | E / 35 | D / 35 |
| 470 | 410 | C / 28 | B / 28 | B / 42 | B / 28 | A / 28 | B / 56 | G / 33 | F / 33 | E / 33 | F / 32 | E / 32 | D / 32 |
| 470 | 400 | B / 35 | C / 35 | B / 36 | B / 25 | A / 24 | B / 53 | G / 27 | F / 29 | E / 29 | F / 29 | E / 29 | D / 29 |
| 460 | 460 | A / 41 | A / 52 | B / 79 | A / 41 | A / 54 | B / 83 | D / 29 | C / 29 | B / 29 | D / 30 | C / 30 | B / 29 |
| 460 | 450 | A / 37 | A / 49 | B / 76 | A / 39 | A / 52 | B / 81 | D / 26 | C / 26 | B / 26 | D / 28 | C / 28 | B / 28 |
| 460 | 440 | A / 33 | A / 45 | B / 72 | A / 37 | A / 50 | B / 79 | E / 35 | D / 35 | C / 35 | D / 26 | C / 26 | B / 26 |
| 460 | 430 | A / 28 | A / 41 | B / 68 | A / 35 | A / 48 | B / 77 | E / 31 | D / 31 | C / 31 | D / 24 | C / 24 | B / 24 |

| Frame type | | Frame 75° long | | | | | | Frame 75° short | | | | | |
|----------------------|-----------|--|--------|--------|-----------|--------|--------|--------------------------|--------|--------|-----------|--------|--------|
| Seat depth (SD) [mm] | | 340 – 380 ⁽¹⁾ | | | 400 – 480 | | | 340 – 380 ⁽¹⁾ | | | 400 – 480 | | |
| Castor wheel size | | 3" | 4" | 5" | 3" | 4" | 5" | 3" | 4" | 5" | 3" | 4" | 5" |
| FSTF [mm] | RSTF [mm] | Castor fork mounting position (A-H) / Distance from castor supporter to frame tube end (x) | | | | | | | | | | | |
| 460 | 420 | A / 23 | A / 36 | B / 64 | A / 32 | A / 45 | B / 74 | E / 27 | D / 27 | C / 27 | E / 35 | D / 35 | C / 35 |
| 460 | 410 | B / 32 | A / 31 | B / 59 | A / 29 | A / 42 | B / 71 | E / 23 | D / 23 | C / 23 | E / 32 | D / 32 | C / 32 |
| 460 | 400 | B / 26 | A / 25 | B / 54 | A / 26 | A / 39 | B / 68 | F / 31 | E / 31 | D / 31 | E / 30 | D / 30 | C / 30 |
| 460 | 390 | C / 33 | B / 33 | B / 48 | B / 35 | A / 35 | B / 64 | F / 26 | E / 26 | D / 26 | E / 28 | D / 28 | C / 28 |
| 450 | 450 | A / 52 | A / 63 | B / 90 | A / 52 | A / 65 | B / 94 | C / 27 | B / 26 | B / 40 | C / 27 | B / 26 | B / 39 |
| 450 | 440 | A / 47 | A / 59 | B / 86 | A / 50 | A / 63 | B / 92 | C / 23 | B / 23 | B / 36 | C / 25 | B / 25 | B / 38 |
| 450 | 430 | A / 43 | A / 55 | B / 83 | A / 48 | A / 61 | B / 90 | D / 33 | C / 33 | B / 33 | C / 23 | B / 23 | B / 36 |
| 450 | 420 | A / 39 | A / 51 | B / 79 | A / 46 | A / 59 | B / 87 | D / 29 | C / 29 | B / 29 | D / 34 | C / 34 | B / 34 |
| 450 | 410 | A / 34 | A / 47 | B / 75 | A / 43 | A / 56 | B / 84 | D / 25 | C / 25 | B / 25 | D / 32 | C / 32 | B / 32 |
| 450 | 400 | A / 29 | A / 42 | B / 70 | A / 40 | A / 53 | B / 81 | E / 33 | D / 33 | C / 33 | D / 30 | C / 30 | B / 29 |
| 450 | 390 | A / 23 | A / 36 | B / 65 | A / 37 | A / 49 | B / 78 | E / 29 | D / 29 | C / 29 | D / 28 | C / 28 | B / 28 |

| Frame type | | Frame 90° long | | | | | | Frame 90° short | | | | | |
|----------------------|-----------|--|--------|--------|-----------|--------|--------|--------------------------|----|----|-----------|----|----|
| Seat depth (SD) [mm] | | 340 – 380 ⁽¹⁾ | | | 400 – 480 | | | 340 – 380 ⁽¹⁾ | | | 400 – 480 | | |
| Castor wheel size | | 3" | 4" | 5" | 3" | 4" | 5" | 3" | 4" | 5" | 3" | 4" | 5" |
| FSTF [mm] | RSTF [mm] | Castor fork mounting position (A-H) / Distance from castor supporter to frame tube end (x) | | | | | | | | | | | |
| 540 | 490 | — | — | E / 23 | — | F / 32 | D / 32 | — | — | — | — | — | — |
| 540 | 480 | — | — | F / 31 | — | F / 30 | D / 30 | — | — | — | — | — | — |
| 540 | 470 | — | — | F / 27 | — | F / 28 | E / 28 | — | — | — | — | — | — |
| 540 | 460 | — | — | E / 29 | — | F / 25 | E / 25 | — | — | — | — | — | — |
| 540 | 450 | — | — | G / 31 | — | G / 35 | F / 35 | — | — | — | — | — | — |
| 540 | 440 | — | — | G / 29 | — | G / 32 | F / 32 | — | — | — | — | — | — |
| 530 | 490 | — | E / 24 | D / 24 | F / 31 | E / 31 | D / 31 | — | — | — | — | — | — |
| 530 | 480 | — | F / 32 | E / 32 | F / 29 | E / 29 | D / 29 | — | — | — | — | — | — |
| 530 | 470 | — | F / 29 | E / 29 | F / 27 | E / 27 | D / 27 | — | — | — | — | — | — |
| 530 | 460 | — | F / 24 | E / 24 | F / 25 | E / 25 | D / 25 | — | — | — | — | — | — |
| 530 | 450 | — | G / 32 | F / 32 | G / 35 | F / 35 | E / 35 | — | — | — | — | — | — |
| 530 | 440 | — | G / 29 | F / 27 | G / 33 | F / 33 | E / 33 | — | — | — | — | — | — |
| 530 | 430 | — | G / 29 | G / 34 | G / 30 | F / 30 | E / 30 | — | — | — | — | — | — |
| 520 | 490 | E / 25 | D / 25 | C / 25 | E / 30 | D / 30 | C / 30 | — | — | — | — | — | — |
| 520 | 480 | F / 34 | E / 34 | D / 34 | E / 28 | D / 28 | C / 28 | — | — | — | — | — | — |
| 520 | 470 | F / 30 | E / 30 | D / 30 | E / 27 | D / 27 | C / 27 | — | — | — | — | — | — |
| 520 | 460 | F / 26 | E / 26 | D / 26 | E / 25 | D / 25 | C / 25 | — | — | — | — | — | — |
| 520 | 450 | G / 35 | F / 35 | E / 35 | F / 35 | E / 35 | D / 35 | — | — | — | — | — | — |
| 520 | 440 | G / 31 | F / 30 | E / 30 | F / 33 | E / 33 | D / 33 | — | — | — | — | — | — |
| 520 | 430 | G / 29 | F / 25 | E / 25 | F / 30 | E / 30 | D / 30 | — | — | — | — | — | — |

| Frame type | | Frame 90° long | | | | | | Frame 90° short | | | | | |
|----------------------|-----------|--|--------|--------|-----------|--------|--------|--------------------------|--------|--------|-----------|--------|--------|
| Seat depth (SD) [mm] | | 340 – 380 ⁽¹⁾ | | | 400 – 480 | | | 340 – 380 ⁽¹⁾ | | | 400 – 480 | | |
| Castor wheel size | | 3" | 4" | 5" | 3" | 4" | 5" | 3" | 4" | 5" | 3" | 4" | 5" |
| FSTF [mm] | RSTF [mm] | Castor fork mounting position (A-H) / Distance from castor supporter to frame tube end (x) | | | | | | | | | | | |
| 520 | 420 | G / 29 | G / 31 | F / 32 | F / 27 | E / 27 | D / 27 | — | — | — | — | — | — |
| 510 | 480 | E / 35 | D / 35 | C / 35 | D / 27 | C / 27 | B / 27 | — | — | — | — | — | F / 33 |
| 510 | 470 | E / 32 | D / 32 | C / 32 | D / 26 | C / 26 | B / 26 | — | — | — | — | — | F / 32 |
| 510 | 460 | E / 28 | D / 28 | C / 28 | D / 24 | C / 24 | B / 24 | — | — | — | — | — | F / 30 |
| 510 | 450 | E / 24 | D / 24 | C / 24 | E / 35 | D / 35 | C / 35 | — | — | — | — | — | F / 29 |
| 510 | 440 | F / 32 | E / 32 | D / 32 | E / 33 | D / 33 | C / 33 | — | — | — | — | — | F / 27 |
| 510 | 430 | F / 27 | E / 27 | D / 27 | E / 31 | D / 31 | C / 31 | — | — | — | — | — | F / 25 |
| 510 | 420 | G / 35 | F / 35 | E / 35 | E / 28 | D / 28 | C / 28 | — | — | — | — | — | G / 35 |
| 510 | 410 | G / 29 | F / 27 | E / 27 | E / 27 | D / 27 | C / 27 | — | — | — | — | — | G / 33 |
| 500 | 470 | D / 33 | C / 33 | B / 32 | C / 25 | B / 25 | B / 37 | — | — | E / 25 | — | F / 31 | E / 31 |
| 500 | 460 | D / 29 | C / 29 | B / 29 | C / 23 | B / 23 | B / 36 | — | — | F / 35 | — | F / 30 | E / 30 |
| 500 | 450 | D / 25 | C / 25 | B / 25 | D / 34 | C / 34 | B / 34 | — | — | F / 32 | — | F / 28 | E / 28 |
| 500 | 440 | E / 34 | D / 34 | C / 34 | D / 32 | C / 32 | B / 32 | — | — | F / 28 | — | F / 26 | E / 26 |
| 500 | 430 | E / 29 | D / 29 | C / 29 | D / 31 | C / 31 | B / 30 | — | — | F / 24 | — | F / 24 | E / 24 |
| 500 | 420 | E / 24 | D / 24 | C / 24 | D / 28 | C / 28 | B / 28 | — | — | G / 33 | — | G / 35 | F / 35 |
| 500 | 410 | F / 32 | E / 32 | D / 32 | D / 25 | C / 25 | B / 25 | — | — | G / 29 | — | G / 33 | F / 33 |
| 500 | 400 | F / 27 | E / 27 | D / 27 | E / 35 | D / 35 | C / 35 | — | — | G / 29 | — | G / 30 | F / 30 |
| 490 | 460 | C / 30 | B / 30 | B / 42 | C / 35 | B / 34 | B / 47 | — | E / 23 | D / 23 | F / 28 | E / 28 | D / 28 |
| 490 | 450 | C / 26 | B / 26 | B / 39 | C / 34 | B / 33 | B / 46 | — | F / 33 | E / 33 | F / 27 | E / 27 | D / 27 |
| 490 | 440 | C / 23 | B / 23 | B / 35 | C / 32 | B / 31 | B / 45 | — | F / 29 | E / 29 | F / 25 | E / 25 | D / 25 |
| 490 | 430 | D / 31 | C / 31 | B / 31 | C / 30 | B / 29 | B / 43 | — | F / 25 | E / 25 | F / 23 | E / 23 | D / 23 |
| 490 | 420 | D / 27 | C / 27 | B / 27 | C / 28 | B / 28 | B / 41 | — | G / 34 | F / 34 | G / 35 | F / 35 | E / 35 |
| 490 | 410 | E / 35 | D / 35 | C / 35 | C / 25 | B / 25 | B / 38 | — | G / 30 | F / 30 | G / 32 | F / 32 | E / 32 |
| 490 | 400 | E / 30 | D / 30 | C / 30 | C / 23 | B / 23 | B / 36 | — | G / 29 | F / 25 | G / 30 | F / 30 | E / 30 |
| 490 | 390 | E / 27 | D / 27 | C / 27 | D / 32 | C / 32 | B / 33 | — | G / 29 | G / 33 | G / 29 | F / 28 | E / 28 |
| 480 | 450 | B / 27 | A / 26 | B / 53 | B / 30 | A / 31 | B / 58 | F / 33 | E / 33 | D / 33 | E / 25 | D / 25 | C / 25 |
| 480 | 440 | B / 24 | A / 23 | B / 49 | B / 31 | A / 30 | B / 56 | F / 30 | E / 30 | D / 30 | E / 24 | D / 24 | C / 24 |
| 480 | 430 | C / 34 | B / 33 | B / 46 | B / 30 | A / 28 | B / 55 | F / 27 | E / 27 | D / 27 | E / 23 | D / 23 | C / 23 |
| 480 | 420 | C / 29 | B / 29 | B / 42 | B / 27 | A / 26 | B / 53 | F / 23 | E / 23 | D / 23 | F / 34 | E / 34 | D / 34 |
| 480 | 410 | C / 24 | B / 24 | B / 37 | B / 25 | A / 24 | B / 51 | G / 30 | F / 32 | E / 32 | F / 32 | E / 32 | D / 32 |
| 480 | 400 | D / 32 | C / 32 | B / 32 | C / 35 | B / 34 | B / 49 | G / 29 | F / 27 | E / 27 | F / 30 | E / 30 | D / 30 |
| 480 | 390 | D / 27 | C / 27 | B / 27 | C / 33 | B / 32 | B / 46 | G / 29 | F / 23 | E / 23 | F / 28 | E / 28 | D / 28 |
| 470 | 440 | A / 25 | A / 36 | B / 63 | A / 30 | A / 41 | B / 68 | E / 30 | D / 30 | C / 30 | D / 23 | C / 23 | B / 23 |
| 470 | 430 | B / 34 | A / 33 | B / 60 | A / 28 | A / 40 | B / 66 | E / 27 | D / 27 | C / 27 | E / 34 | D / 34 | C / 34 |
| 470 | 420 | B / 30 | A / 29 | B / 56 | A / 27 | A / 38 | B / 65 | E / 24 | D / 24 | C / 24 | E / 33 | D / 33 | C / 33 |
| 470 | 410 | B / 26 | A / 25 | B / 52 | A / 25 | A / 36 | B / 63 | F / 34 | E / 34 | D / 34 | E / 31 | D / 31 | C / 31 |
| 470 | 400 | B / 23 | B / 35 | B / 48 | B / 35 | A / 34 | B / 61 | F / 29 | E / 29 | D / 29 | E / 29 | D / 29 | C / 29 |

| Frame type | | Frame 90° long | | | | | | Frame 90° short | | | | | |
|----------------------|-----------|--|--------|--------|-----------|--------|--------|--------------------------|--------|--------|-----------|--------|--------|
| Seat depth (SD) [mm] | | 340 – 380 ⁽¹⁾ | | | 400 – 480 | | | 340 – 380 ⁽¹⁾ | | | 400 – 480 | | |
| Castor wheel size | | 3" | 4" | 5" | 3" | 4" | 5" | 3" | 4" | 5" | 3" | 4" | 5" |
| FSTF [mm] | RSTF [mm] | Castor fork mounting position (A-H) / Distance from castor supporter to frame tube end (x) | | | | | | | | | | | |
| 470 | 390 | C / 30 | B / 30 | B / 43 | B / 33 | A / 32 | B / 59 | F / 25 | E / 25 | D / 25 | E / 27 | D / 27 | C / 27 |
| 460 | 430 | A / 35 | A / 46 | B / 73 | A / 40 | A / 51 | B / 78 | D / 28 | C / 28 | B / 28 | D / 33 | C / 33 | B / 33 |
| 460 | 420 | A / 31 | A / 43 | B / 70 | A / 38 | A / 50 | B / 77 | D / 25 | C / 25 | B / 25 | D / 32 | C / 32 | B / 32 |
| 460 | 410 | A / 28 | A / 40 | B / 66 | A / 37 | A / 49 | B / 75 | E / 34 | D / 34 | C / 34 | D / 30 | C / 30 | B / 30 |
| 460 | 400 | A / 24 | A / 36 | B / 63 | A / 35 | A / 47 | B / 74 | E / 31 | D / 31 | C / 31 | D / 29 | C / 29 | B / 29 |
| 460 | 390 | B / 32 | A / 31 | B / 58 | A / 33 | A / 45 | B / 72 | E / 27 | D / 27 | C / 27 | D / 27 | C / 27 | B / 27 |
| 450 | 420 | A / 45 | A / 57 | B / 83 | A / 50 | A / 62 | B / 88 | C / 25 | B / 25 | B / 38 | C / 31 | B / 30 | B / 43 |
| 450 | 410 | A / 42 | A / 54 | B / 80 | A / 49 | A / 60 | B / 87 | D / 35 | C / 35 | B / 35 | C / 30 | B / 29 | B / 42 |
| 450 | 400 | A / 38 | A / 50 | B / 77 | A / 47 | A / 59 | B / 86 | D / 32 | C / 32 | B / 32 | C / 28 | B / 28 | B / 41 |
| 450 | 390 | A / 34 | A / 46 | B / 73 | A / 45 | A / 57 | B / 84 | D / 28 | C / 28 | B / 28 | C / 26 | B / 26 | B / 39 |

Light grey table cells: Not possible for SK option

Dark grey table cells: SK option only possible as "MY Kuschall".

⁽¹⁾ For SD 380 mm, 5 mm have to be added to the dimensions in the table.

For SD 340 mm, 5 mm have to be removed from the dimensions in the table.

6.2.2 Adjusting the rear seat-to-floor height (RSTF)

The following possibilities are available to adjust the rear seat-to-floor height (RSTF):

- Adjusting the adapter plate to the folding unit, see chapter 6.8.5 *Adapter plate — Adjusting the folding unit / Installing the adapter plate, page 36.*
- Replacing the rear wheel with a larger or smaller one.



Ensure that the rear wheels are parallel after changing the rear seat height. Readjust if required. See chapter 6.8.2 *Wheel camber, adapter sleeves, page 35.*



Ensure that the castor pins are vertical after changing the rear seat height. Readjust if required. See chapter 6.7.4 *Checking and adjusting the drift angle, page 34.*

6.2.3 Replacing the seat cover



Allen key (3 mm)



1. Fit seat cover to side supports and frame on both sides using bolts **A** and **B**.

A = 13 Nm

B = 5 Nm

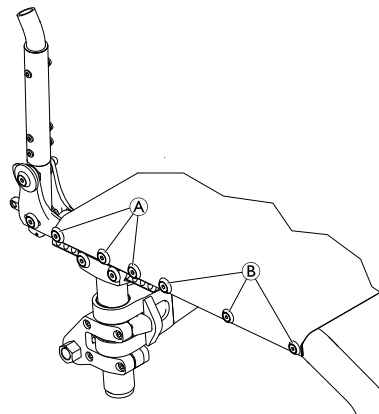

6.3 Adjusting the folding mechanism



Allen key (3 mm) / Wrench (16 mm) / Feeler gauge (0,2 mm)



1. Remove the end-stop nut © from bolt ⑤.
2. Apply new thread locking adhesive on bolt ⑤.
3. Screw the end-stop nut completely on the bolt again, but do not tighten.
4. Adjust the end stop ⑥ of the folding unit by tightening resp. loosening the grub screw ④.

IMPORTANT!

The main purpose of the end-stops is to avoid any torsion movement of the folding mechanism while driving the wheelchair on uneven terrain.

- Make sure that the end stops do not have any contact to the folding mechanism (positions A and B).
- Make sure that the upper and lower edges (positions A and B) of the end-stops have a distance of 0.2 mm to the folding mechanism (check with feeler gauge).

IMPORTANT!

The end-stops can turn around their own axis once they are loose.

- Make sure that the end-stops are completely horizontal when retightening the end-stop nut.

5. Tighten the end-stop nut.
6. Carry out the same settings on both sides.
7. Check that the scissor mechanism opens and closes easily.



A noticeable resistance just before the chair is unfolded completely is normal and even desired to improve the rigidity of the frame.

8. Check the seat cover for sufficient tension in unfolded condition of the wheelchair.
9. If necessary, repeat the steps above until all settings are correct.

© = 13 Nm (high-strength)

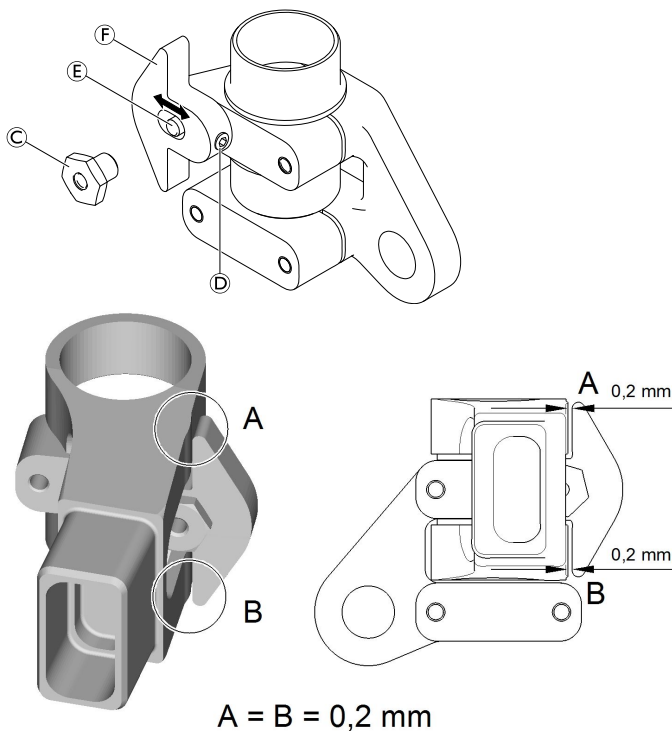

6.4 Backrest

6.4.1 Tension adjustable backrest

! **IMPORTANT!**
Risk of damage to the wheelchair
 A too tight band installation may cause damage to the backrest when unfolding the wheelchair.
 – Make sure that the backrest bands are only adjusted in unfolded condition of the wheelchair.

Tension adjustable backrest with standard push handles

| BH [mm] | Push handle | Inter- me- diate tube | Hook-and-loop straps without stabilisation bar | | Hook-and-loop straps with stabilisation bar | | Back- rest cover |
|------------|-------------|--------------------------------|--|---------|---|-------|------------------------|
| | (A) | | (B) | (C) | (D) | (C) | |
| 300 | S | S | L | S + M | not possible | | S |
| 315 | S | S | L | S + M | | | S |
| 330 | S | L | L | S + M | | | S |
| 345 | S | L | L | 2xM | | | M |
| 360 | S | L | L | 2xM | | | M |
| 375 | S | L | L | 2xM | | | M |
| 390 | S | L | L | 2xM | | | M |
| 405 | L | L | L | S + 2xM | S | S + L | L |
| 420 | L | L | L | S + L | S | S + L | L |
| 435 | L | L | L | S + L | S | S + L | L |
| 450 | L | L | L | S + L | S | M + L | L |
| 465 | L | L | L | M + L | S | M + L | L |

Tension adjustable backrest with foldable push handles

| BH [mm] | Tele- scopic tube | Inter- me- diate tube | Hook-and-loop straps without stabilisation bar | | Hook-and-loop straps with stabilisation bar | | Back- rest cover |
|------------|-------------------------|--------------------------------|--|---------|---|-------|------------------------|
| | (A) | | (B) | (C) | (D) | (C) | |
| 300 | S | S | L | S + M | not possible | | S |
| 315 | S | S | L | S + M | | | S |
| 330 | S | L | L | S + M | | | S |
| 345 | S | L | L | 2xM | | | M |
| 360 | S | L | L | 2xM | | | M |
| 375 | S | L | L | 2xM | | | M |
| 390 | S | L | L | 2xM | | | M |
| 405 | L | L | L | S + 2xM | S | S + L | L |
| 420 | L | L | L | S + L | S | S + L | L |
| 435 | L | L | L | S + L | S | S + L | L |
| 450 | L | L | L | S + L | S | M + L | L |
| 465 | L | L | L | M + L | S | M + L | L |

Tension adjustable backrest without push handles

| BH [mm] | Tele- scopic tube | Inter- me- diate tube | Hook-and-loop straps without stabilisation bar | | Hook-and-loop straps with stabilisation bar | | Back- rest cover |
|------------|-------------------------|--------------------------------|--|---------|---|-------|------------------------|
| | Ⓐ | Ⓑ | Ⓒ | Ⓓ | Ⓒ | Ⓓ | |
| 300 | S | S | L | S + M | not possible | | S |
| 315 | L | S | L | S + M | | | S |
| 330 | L | S | L | S + M | | | S |
| 345 | L | S | L | 2xM | | | M |
| 360 | L | S | L | 2xM | | | M |
| 375 | L | L | L | 2xM | | | M |
| 390 | L | L | L | 2xM | | | M |
| 405 | L | L | L | S + 2xM | S | S + L | L |
| 420 | L | L | L | S + L | S | S + L | L |
| 435 | L | L | L | S + L | S | S + L | L |
| 450 | XL | L | L | S + L | S | M + L | L |
| 465 | XL | L | L | M + L | S | M + L | L |

Tension adjustable backrest with rear-set height adjustable push handles

| BH [mm] | Tele- scopic tube | Inter- me- diate tube | Hook-and-loop straps without stabilisation bar | | Hook-and-loop straps with stabilisation bar | | Back- rest cover |
|------------|-------------------------|--------------------------------|--|-------|---|-------|------------------------|
| | Ⓐ | Ⓑ | Ⓒ | Ⓓ | Ⓒ | Ⓓ | |
| 300 | S | S | L | 2xS | not possible | | S |
| 315 | L | S | L | 2xS | | | S |
| 330 | L | S | L | 2xS | | | S |
| 345 | L | S | L | S + M | | | M |
| 360 | L | S | L | S + M | | | M |
| 375 | L | L | S | 2xM | | | M |
| 390 | L | L | L | 2xM | | | M |
| 405 | L | L | L | 2xM | S | M | L |
| 420 | L | L | L | 2xM | S | M | L |
| 435 | L | L | L | 2xM | S | S + M | L |
| 450 | XL | L | L | 2xM | S | S + M | L |
| 465 | XL | L | L | L | S | S + M | L |

Tension adjustable backrest with integrated height-adjustable push handles

| BH [mm] | Push handle | Inter- mediate tube | Hook-and-loop straps without stabilisation bar | | Hook-and-loop straps with stabilisation bar | | Back- rest cover |
|------------|---------------------------------|---------------------------|--|------------|---|-------|------------------------|
| | Ⓐ | | Ⓑ | Ⓒ | Ⓓ | Ⓒ | |
| 300 | Stan- dard push handle | S | L | S + M | not possible | | S |
| 315 | | S | L | S + M | | | S |
| 330 | | M | L | S + M | | | S |
| 345 | | M | L | 2xM | | | M |
| 360 | | M | L | 2xM | | | M |
| 375 | | M | L | 2xM | | | M |
| 390 | | M | L | 2xM | M | | |
| 405 | | L | L | S + 2xM | S | S + L | L |
| 420 | | L | L | S + L | S | S + L | L |
| 435 | | L | L | S + L | S | S + L | L |
| 450 | L | L | S + L | S | M + L | L | |
| 465 | L | L | M + L | S | M + L | L | |

6.4.2 Backrest height (BH)

The backrest height (BH) can be changed by fitting the telescopic tubes into another position in the backrest tubes. If this setting option is insufficient, the telescopic tubes can be replaced.

Adjusting the height of standard backrests

 Allen key (3 mm) / Wrench (8 mm) ■ □ □

1. Push the backrest cover Ⓐ so that bolt and nut on the backrest tube are uncovered.
2. Remove bolt and nut with washer Ⓑ.
3. Adjust the backrest tube Ⓒ to the required height then insert the screw Ⓓ into the closest hole and retighten.
4. Carry out the same setting on both sides.
5. Reposition the backrest cover correctly.

Ⓑ = 7 Nm

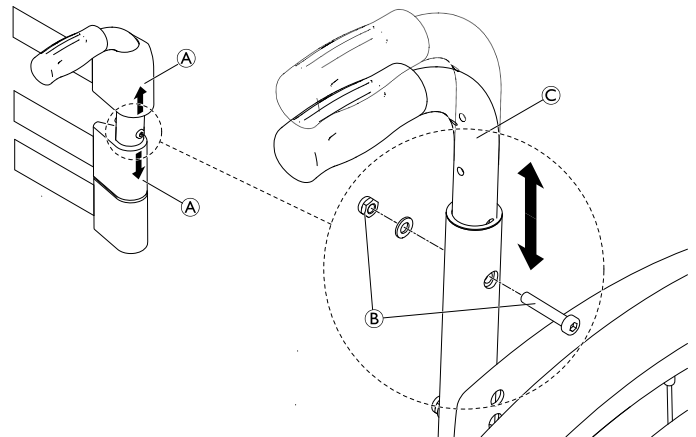

6.4.3 Backrest angle (BA)

Adjusting the backrest angle



Allen key (4 mm) / Wrench (10 mm)



1. Remove the lower bolt and nut (A) from the side supporter (B) and move the backrest (C) to the required position. The spacer (D) remains fixed in the latch bolt (E).
2. Insert bolt and nut (A) into the closest hole and tighten it again.
3. Carry out the same setting on both sides.

(A) = 13 Nm

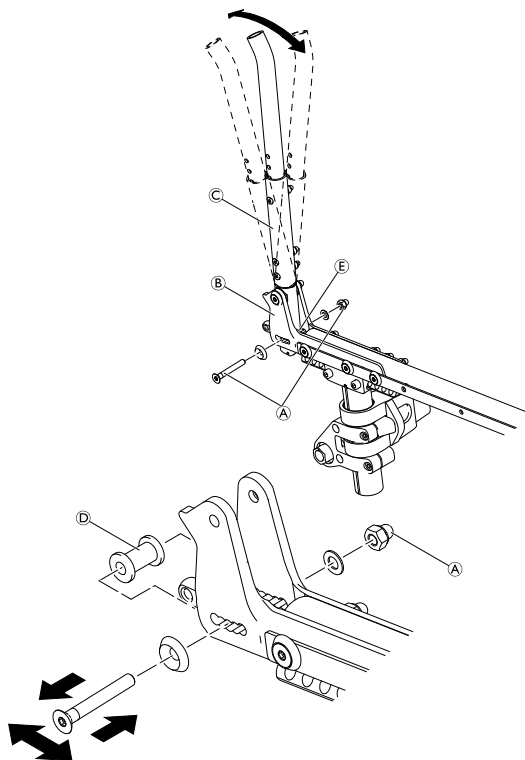

Function control:

The backrest must fold easily and the ratchet bolt must sit tightly against the side supporter.

6.4.4 Push handles / telescopic tubes

Replacing the push handles / telescopic tubes



Allen key (4 mm) / Wrench (10 mm) / Phillips screwdriver (2 mm)



1. Remove the backrest cover (A).
2. Remove the screws (C) holding the uppermost backrest band (B) (or standard backrest cover) to the push handles (E) (or telescopic tubes).
3. Slide the backrest straps (D) (or standard backrest cover) either up or down to locate the fixing bolt (F).
4. Remove bolts and nuts on both sides (F).
5. Remove push handles (E) (or telescopic tubes).
6. Slide new push handle through backrest band (B) and fix it on the backrest with bolt (F).
7. Fix the uppermost backrest band (B) (or standard backrest cover) with screws (C).
8. Carry out the same setting on both sides.
9. Reposition the backrest cover correctly.

(C) = 4 Nm

(F) = 7 Nm

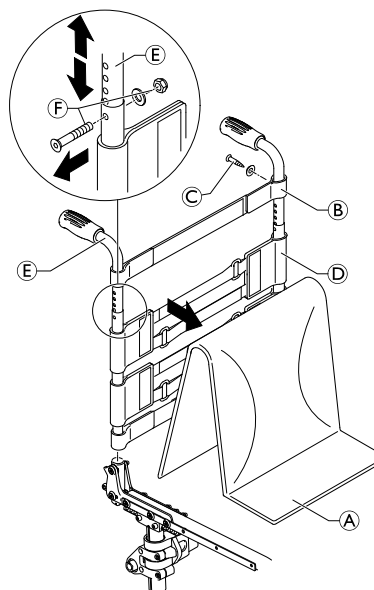

Adjusting the height of integrated push handles



Allen key (3 mm) / Wrench (8 mm) / Phillips screwdriver (2 mm)



1. Install the backrest tube **A** corresponding to the desired backrest height (BH) on both sides using the bolts **B**.
2. Slide the backrest bands **C** corresponding to the desired backrest height (BH) and, if required, the end band **D** (or the standard backrest cover) over the backrest tube **A**.
3. Slide the push handle **F** into the backrest tube **A** on both sides and secure it at the desired height using the clamp bolt **G**.
4. Secure the end band **D** (or the standard backrest cover) to the backrest tube **A** on both sides using the screws **E**.

B = 4 Nm

E = 7 Nm

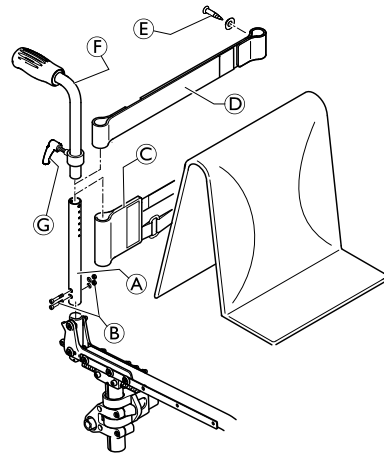

Adjusting the height of rear-set push handles

The rear-set push handles can only be used in combination with adjustable backrests, not with standard backrests.



Allen key (3 mm) / Wrench (8 mm) / Phillips screwdriver (2 mm)



1. Install the intermediate tube **A** on both sides using the bolts **B**.
2. Slide the backrest bands **C** corresponding to the desired backrest height (BH) onto the intermediate tube.
3. Fit the telescopic tube **D** corresponding to the desired backrest height (BH) on both sides using the bolt **E**.
4. Slide the holder **F** and the sleeve **G** onto the telescopic tube **D** and secure it using the screws **H**.

 For the minimum backrest height, the holder of the rear-set push handle must be fitted to the intermediate tube **A**. In this case, the sleeve **G** is not required.

5. Slide the end band **I** onto the telescopic tube **D** and secure it on both sides using the screws **J**.

B = 7 Nm

E = 7 Nm

H = 13 Nm

J = 4 Nm

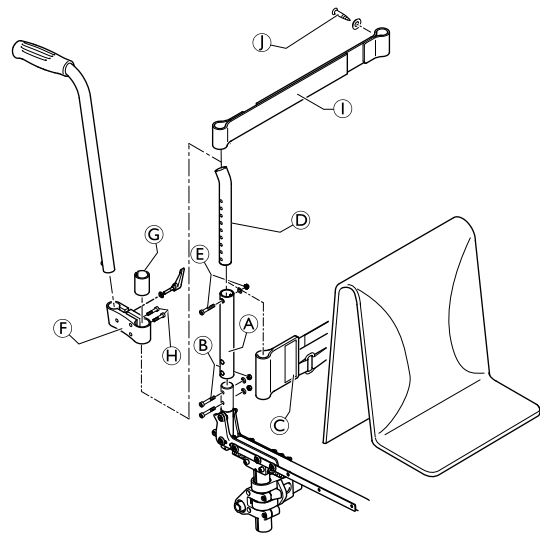

Replacing the handle

An adhesive (for example, hair spray) is used in these instructions. When applied to the handle, this substance works as a lubricant and as an adhesive once dry.



CAUTION! Risk of accidents

The handle can come loose from the tube if not correctly bonded.
– Make sure that the handle resists a pull-off force of 750 Nm after drying.



Adhesive (e.g. hair spray)



1. Remove the old handle.
2. Remove any residue (residual adhesive, grease, dust) from the push handle tube.
3. Apply a thin layer of hair spray all over the surface of the push handle tube onto which the handle is to be slid.
4. Apply a thin layer of hair spray to the inside of the handle.
5. Slide the new handle onto the push handle tube.
6. Move the handle into the correct position (grooves facing upwards).

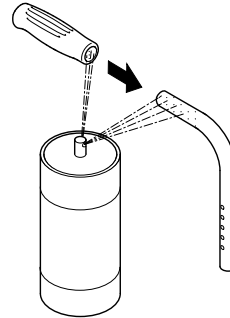

 If a long handle has been fitted and this is to be replaced with a short one, the push handle tube must be shortened by 35 mm. The push handle tube must be replaced when switching from a short to a long handle.

Replacing foldable push handles



Hole punch pliers (6 mm) / Allen key (3 mm, 4 mm)



1. Remove the old foldable push handle.
2. Pull down the backrest cover **F** on the telescopic tube, until hole **B** is uncovered.

IMPORTANT!

– Make sure that the threaded insert **E** supplied with the new push handle is used for assembly.

3. Place the threaded insert **E** in the telescopic tube.
4. Punch a hole through the backrest cover with a distance of 10 mm from the upper edge, using hole punch pliers (see lower graphic to the right).
5. Slide the new foldable push handle **A** onto the telescopic tube.
6. Pull up the backrest cover, until it completely covers the rear hole in the push handle.
7. Fix the foldable push handle with screw **C** and washer **G**.
8. Check screws **D** on both sides of the push handle and re-tighten if necessary.
9. Carry out the same steps for the other push handle.

IMPORTANT!

– Make sure that the folding force is approximately 5 N (0.5 kg).

IMPORTANT!

– Fixing screw **C** may only be used once. Alternatively the screw can be cleaned (remove old thread locking adhesive) and reinstalled with new low-strength thread locking adhesive.



The retrofit of foldable push handles requires new tubing.

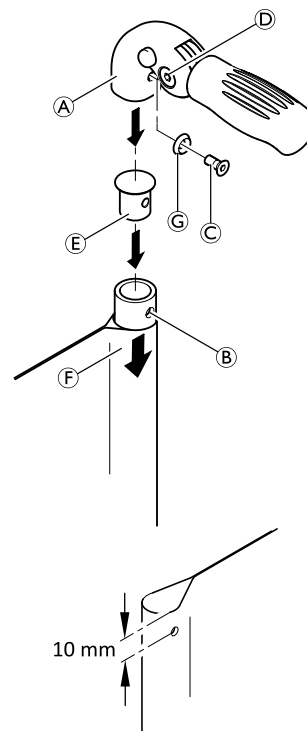

© =7 Nm (low-strength)

6.4.5 Installing the stabilisation bar



Allen key (3 mm) / Socket spanner (8 mm) / Phillips screwdriver (2)



With a back height RH405 or larger it is possible to install a stabilisation bar to increase the rigidity of the backrest handles.

1. Remove backrest cover **A**, push handles **B** and the 10 cm backrest band (or end band, if no push handles are assembled).
2. Install a 5 cm backrest band **C** or end band with the screws **L** to the push handles **B**.
3. Install the push handles **B** with bolts and nuts **K**.
4. Attach the clamps **D** together with the right-hand socket **F** and the left-hand socket **H** with the screws **G** below the backrest band **C** to the push handles **B**.
5. Press pin **E** and slide the stabilisation bar **J** into the right-hand socket **F** then swing the stabilisation bar upwards, press pin **I** and click the stabilisation bar into the left-hand socket **H**.

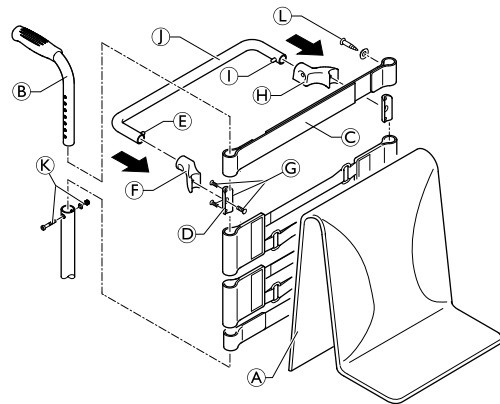

G = 4 Nm

K = 7 Nm

L = 4 Nm

6.5 Footrests

Lower leg length (LLL)

To change the lower leg length, the footrest can be installed in a higher or lower position, *6.5.1 Replacing the footrest, page 27*.

| LLL [mm] | Footrest / Frame |
|-----------|---------------------------------|
| 320 – 390 | Standard footrest / Short frame |
| 400 – 500 | Standard footrest / Long frame |

LLL from 320 to 370 is not possible with folding front frame (SK option).

LLL 380 only possible with folding front frame (SK option) when seat depth (SD) is ≥ 400 mm.

LLL 390 only possible with folding front frame (SK option) when seat depth (SD) is ≥ 380 mm.

| Possible foot plate situations in relationship to seat angle and castor wheel size | | | | | | | | | | | | | |
|--|-----------------|----------------------|----|----|-----------|----|----|---------------------|----|----|-----------|----|----|
| | | Front-set foot plate | | | | | | Rear-set foot plate | | | | | |
| Seat depth (SD) [mm] | | 340 - 380 | | | 400 - 480 | | | 340 - 380 | | | 400 - 480 | | |
| | Seat angle [mm] | 3" | 4" | 5" | 3" | 4" | 5" | 3" | 4" | 5" | 3" | 4" | 5" |
| Frame 75° | 0 | ✓ | ✓ | ✓ | ✓ | ✓ | ✓ | ✓ | ✗ | ✗ | ✓ | ✗ | ✗ |
| | 10 | ✓ | ✓ | ✓ | ✓ | ✓ | ✓ | ✓ | ✓ | ✗ | ✓ | ✓ | ✗ |
| | 20 | ✓ | ✓ | ✓ | ✓ | ✓ | ✓ | ✓ | ✓ | ✗ | ✓ | ✓ | ✗ |
| | 30 | ✓ | ✓ | ✓ | ✓ | ✓ | ✓ | ✓ | ✓ | ✗ | ✓ | ✓ | ✗ |
| | 40 | ✓ | ✓ | ✓ | ✓ | ✓ | ✓ | ✓ | ✓ | ✓ | ✓ | ✓ | ✗ |
| | 50 | ✓ | ✓ | ✓ | ✓ | ✓ | ✓ | ✓ | ✓ | ✓ | ✓ | ✓ | ✓ |
| | 60 | ✓ | ✓ | ✓ | ✓ | ✓ | ✓ | ✓ | ✓ | ✓ | ✓ | ✓ | ✓ |
| | 70 | ✓ | ✓ | ✓ | ✓ | ✓ | ✓ | ✓ | ✓ | ✓ | ✓ | ✓ | ✓ |
| Frame 90° | 30 | ✓ | ✓ | ✗ | ✓ | ✓ | ✗ | ✗ | ✗ | ✗ | ✗ | ✗ | ✗ |
| | 40 | ✓ | ✓ | ✗ | ✓ | ✓ | ✗ | ✓ | ✗ | ✗ | ✓ | ✗ | ✗ |
| | 50 | ✓ | ✓ | ✓ | ✓ | ✓ | ✗ | ✓ | ✗ | ✗ | ✓ | ✗ | ✗ |
| | 60 | ✓ | ✓ | ✓ | ✓ | ✓ | ✓ | ✓ | ✗ | ✗ | ✓ | ✗ | ✗ |
| | 70 | ✓ | ✓ | ✓ | ✓ | ✓ | ✓ | ✓ | ✓ | ✗ | ✓ | ✗ | ✗ |
| | 80 | ✓ | ✓ | ✓ | ✓ | ✓ | ✓ | ✓ | ✓ | ✗ | ✓ | ✗ | ✗ |
| | 90 | ✓ | ✓ | ✓ | ✓ | ✓ | ✓ | ✓ | ✓ | ✗ | ✓ | ✓ | ✗ |
| | 100 | ✓ | ✓ | ✓ | ✓ | ✓ | ✓ | ✓ | ✓ | ✓ | ✓ | ✓ | ✗ |

If the lower leg length (LLL) is smaller than the front seat-to-floor height (FSTF) minus 100 mm, there are no conflicts possible between the foot plate and the castors.

6.5.1 Replacing the footrest



Allen key (4 mm) / Wrench (8 mm)



1. Remove the bolts, nuts and washers **A**, which fix the telescopic tube **B** to the frame **C**.
2. Replace the footrest.
3. Extend the footrest telescopic tubes **B** to the required length, then insert the bolts **A** into the closest holes.
4. Carry out the same setting on both sides.
5. Put washers and nuts back on the bolts and tighten.

A = 7 Nm

Function control:

Check that the footrest is firmly installed and that it can be folded easily.

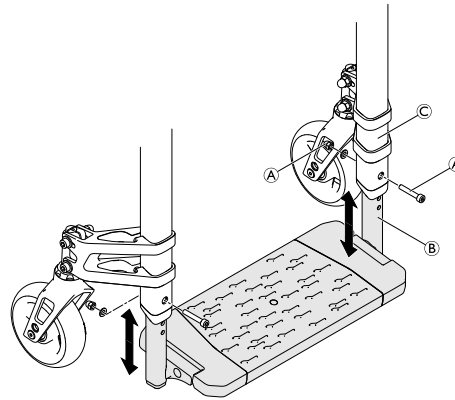

6.5.2 Replacing the foot plate



Allen key (4 mm) / Wrench (8 mm)



1. Remove the screws **A** and the screws **B**.
2. Remove the foot plate **C** and replace it by the new one.
3. Secure the foot plate with the screws **A** and the screws **B**.

A = 7 Nm

B = 7 Nm

Function control:

Check that the footrest is firmly installed and that it can be folded easily.

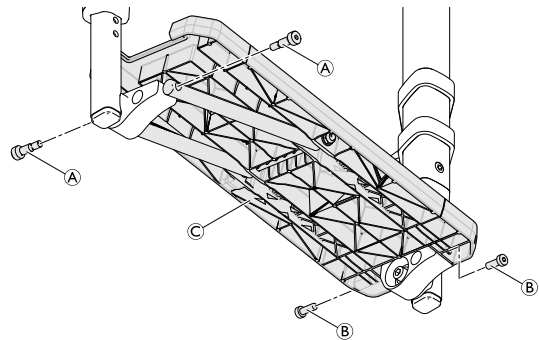

6.5.3 Turning the foot plate

The foot plate can be installed front-set or rear-set. In the standard configuration the foot plate is rear-set.



Allen key (4 mm, 5 mm)



1. Remove the foot plate, see 6.5.2 *Replacing the foot plate*, page 27.
2. Remove the screws and washers **C** on both sides.
3. Rotate the foot plate mounting **D** on both sides by 180°. The elongated sides of the foot plate mountings are now facing forwards.
4. Reinstall the foot plate mounting on both sides using the screws and washers.
5. Reinstall the foot plate, see 6.5.2 *Replacing the foot plate*, page 27.
6. Set the desired foot plate angle and tighten screws **C**, 6.5.4 *Adjusting the foot plate angle*, page 28

A = 7 Nm

B = 7 Nm

C = 7 Nm

Function control:

Check that the footrest is firmly installed and that it can be folded easily.

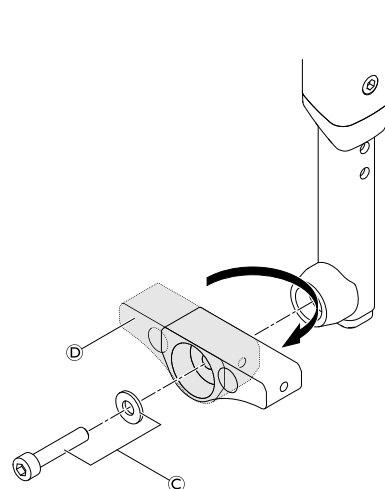

6.5.4 Adjusting the foot plate angle



Allen key (4 mm, 5 mm) / Wrench (8 mm)



1. Slightly loosen the bolts **A** under the foot plate which secure the telescopic tube **B** to the foot plate mounting **C**.
2. Set the foot plate to the desired angle.
3. Retighten bolts **A** on both sides.

A = 7 Nm

Function control:

Check that the foot plate can be folded easily.



To adjust the folding ability of the foot plate, tighten respectively loosen nut **D** on the underside of the foot plate.

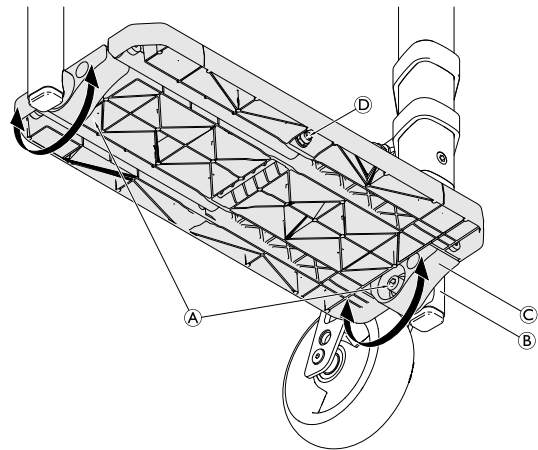

6.6 Sideparts

6.6.1 Installing the clothes-guard



Allen key (4 mm) / Wrench (10 mm)



1. Mount the fixation piece **A** with bolt and nut **B** and bolt and nut **C** to the frame.
2. Align the clothes-guard **D** to the rear wheel and note the best hole on the clothes-guard to fix it to the backrest hinge.
3. Remove the bolt **E** from the backrest joint.
IMPORTANT!
 – If a pelvic belt is fitted, add the washer **F**.
4. Fit the clothes-guard using the bolt present (and any additional washer) to the backrest joint.

B = 13 Nm

C = 7 Nm

E = 13 Nm

Function control:

Fold and unfold the backrest (this must be done easily). Make sure the clothes-guards are positioned slightly higher than the rear wheels. Check that the clothes-guards flip up easily.

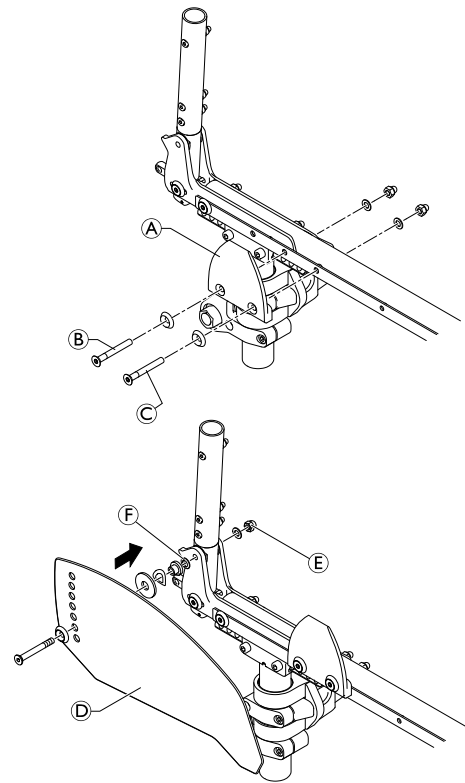

Clothes-guard sizes in relationship to rear seat height, rear wheel size and mounting position of the vertical brace

| Rear wheel 22" | | | | | | | | | |
|----------------|-------|-------|-------|-------|-------|-------|-------|-------|-------|
| RSTF [mm] | Pos 1 | Pos 2 | Pos 3 | Pos 4 | Pos 5 | Pos 6 | Pos 7 | Pos 8 | Pos 9 |
| 390 | M | M | M | M | M | M | M | M | M |
| 400 | M | M | M | M | M | M | M | M | M |
| 410 | M | M | M | M | M | M | M | M | M |
| 420 | M | M | M | S | S | S | S | S | S |
| 430 | M | S | S | S | S | S | S | S | S |
| 440 | S | S | S | S | S | S | S | S | S |
| 450 | — | — | — | S | S | S | S | S | S |
| 460 | — | — | — | — | — | — | — | — | — |
| 470 | — | — | — | — | — | — | — | — | — |
| 480 | — | — | — | — | — | — | — | — | — |
| 490 | — | — | — | — | — | — | — | — | — |

| Rear wheel 24" | | | | | | | | | |
|----------------|-------|-------|-------|-------|-------|-------|-------|-------|-------|
| RSTF [mm] | Pos 1 | Pos 2 | Pos 3 | Pos 4 | Pos 5 | Pos 6 | Pos 7 | Pos 8 | Pos 9 |
| 390 | XL | XL | XL | L | L | L | L | L | L |
| 400 | XL | XL | L | L | L | L | L | L | L |
| 410 | XL | L | L | L | L | L | L | L | L |
| 420 | L | L | L | L | L | M | M | M | M |
| 430 | L | L | L | M | M | M | M | M | M |
| 440 | M | M | M | M | M | M | M | M | M |
| 450 | M | M | M | M | M | M | M | M | M |
| 460 | M | M | M | M | M | M | M | M | M |
| 470 | M | M | M | M | M | M | M | M | M |
| 480 | — | — | — | — | — | — | S | S | S |
| 490 | — | — | — | — | — | — | — | — | — |

| Rear wheel 25" | | | | | | | | | |
|----------------|-------|-------|-------|-------|-------|-------|-------|-------|-------|
| RSTF [mm] | Pos 1 | Pos 2 | Pos 3 | Pos 4 | Pos 5 | Pos 6 | Pos 7 | Pos 8 | Pos 9 |
| 390 | XL | XL | XL | XL | XL | XL | XL | XL | XL |
| 400 | XL | XL | XL | XL | XL | XL | XL | XL | XL |
| 410 | XL | XL | XL | XL | XL | XL | XL | XL | XL |
| 420 | XL | XL | XL | L | L | L | L | L | L |
| 430 | XL | XL | L | L | L | L | L | L | L |
| 440 | L | L | L | L | L | L | L | L | L |
| 450 | L | L | L | L | L | M | M | M | M |
| 460 | L | L | L | L | M | M | M | M | M |
| 470 | L | L | M | M | M | M | M | M | M |
| 480 | M | M | M | M | M | M | M | M | M |
| 490 | — | — | M | M | M | M | M | M | M |

| Rear wheel 26" | | | | | | | | | |
|----------------|-------|-------|-------|-------|-------|-------|-------|-------|-------|
| RSTF [mm] | Pos 1 | Pos 2 | Pos 3 | Pos 4 | Pos 5 | Pos 6 | Pos 7 | Pos 8 | Pos 9 |
| 390 | — | — | — | — | — | — | XL | XL | XL |
| 400 | — | — | — | — | XL | XL | XL | XL | XL |
| 410 | — | — | — | XL | XL | XL | XL | XL | XL |
| 420 | — | — | XL | XL | XL | XL | XL | XL | XL |
| 430 | — | — | XL | XL | XL | XL | XL | XL | XL |
| 440 | — | XL | XL | XL | XL | L | L | L | L |
| 450 | XL | XL | XL | L | L | L | L | L | L |
| 460 | XL | XL | L | L | L | L | L | L | L |
| 470 | XL | L | L | L | L | L | M | M | M |
| 480 | L | L | L | L | M | M | M | M | M |
| 490 | L | L | L | M | M | M | M | M | M |

6.6.2 Installing the mudguard



Allen key (3 mm, 4 mm) / Wrench (10 mm) / Phillips screwdriver (2 mm)



1. Remove the rear wheel.
If installed, remove the clothes-guard and the mounting elements on the backrest and the seat, see 6.6.1 *Installing the clothes-guard, page 29.*
2. Install the holder **B** to the seat module using the screw connections **A** and sleeves **C** and then refit the rear wheel.
3. Slightly loosen the grub screw **D** on the adjustment plate **E** and adjust the mudguard to the desired height.
4. Retighten the grub screw.
5. The position of the mudguard can also be adjusted: Loosen the screw connections **F**, position the mudguard as required and tighten the screw connections again.
6. Carry out the same setting on both sides.
7. Tighten or loosen the screws **G** to adjust how easy the mudguard can be pulled out or pushed in.



The length of the existing quick-release axle may not be sufficient for the new configuration with mudguard. In this case, a longer axle must be fitted.

- A** = 7 Nm
- D** = 4 Nm
- F** = 7 Nm

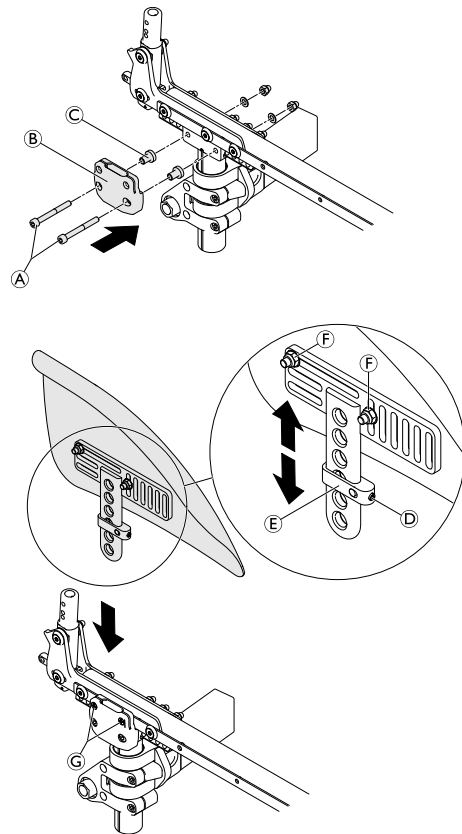

CAUTION!
Risk of injury

The fingers of the wheelchair user may get caught between the wheel and the mudguard.
– Make sure that the distance between the mudguard and the wheel is either < 8 mm or > 25 mm.

Mudguard sizes in relationship to the position of the adapter plate and the rear wheel size

| | | | | | | | | | | | |
|-----------------|------------------------------|--------|--------|--------|--|--------|--|--------|--|--------|--|
| X | cm 1 2 3 4 5 6 7 8 9 10 11 1 | | | | | | | | | | |
| Rear wheel size | 22" | Size 1 | | | | | | | | | |
| | 24" | Size 1 | | Size 2 | | Size 3 | | Size 4 | | | |
| | 25" | Size 1 | | Size 2 | | Size 3 | | Size 4 | | Size 5 | |
| | 26" | | Size 2 | | | Size 3 | | Size 4 | | Size 5 | |
| X | cm 1 2 3 4 5 6 7 8 9 10 11 1 | | | | | | | | | | |

x is defined as the distance from the lower edge of the vertical brace to the lower edge of the axis.

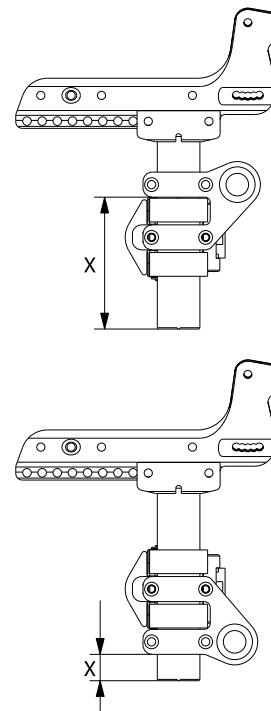

6.6.3 Installing/adjusting the siderest



Allen key (3 mm, 4 mm) / Wrench (10 mm) / Phillips screw driver



1. Install the bracket **B** with the sleeves **C** to the seat module using bolts and nuts **A**.
2. Slightly loosen the grub screw **D** on the adjustment plate **E** and adjust the armrest to the desired height.
3. Retighten the grub screw.
4. By tightening or loosening the screws **F**, you can adjust how easily the armrest can be pulled out or pushed in.



A 3° wheel camber requires that an additional set of distance plates has to be installed between the adapter plate and the side profile.

A = 13 Nm

D = 4 Nm (high-strength)

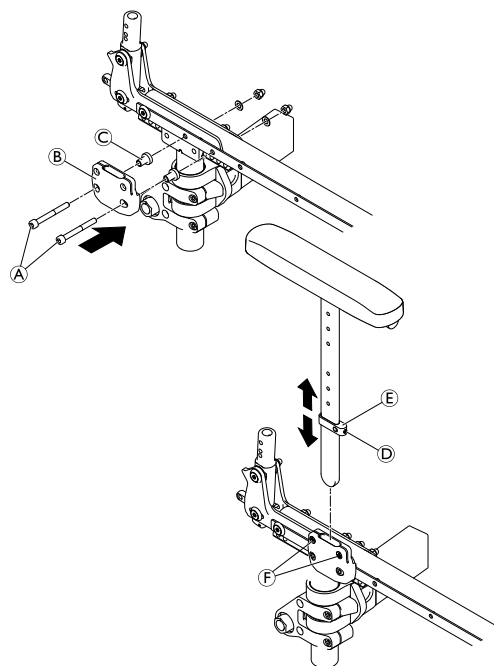

6.6.4 Installing the tubular armrest



Allen key (4 mm) / Wrench (10 mm)



1. Mount the armrest holder **A** with screws **G** and **H**, washers and cap nuts on the side supporter **I**.
2. Place the armrest clamp part sleeve **D** to the third hole from above inside the armrest tube **B**.
3. Insert bolt **C** in smaller hole of the armrest tube and armrest clamp part sleeve.
4. Secure the cylinder head bolt with sleeve **E** and securing cap nut **F**.



If the folding mechanism affects the armrest tube when folding the wheelchair, sleeve **D** must be displaced downwards.

5. Mount the tube plugs and the armrest pad.
6. Place the armrest in the holder.

F = 7 Nm (high-strength)

G = 13 Nm

H = 13 Nm

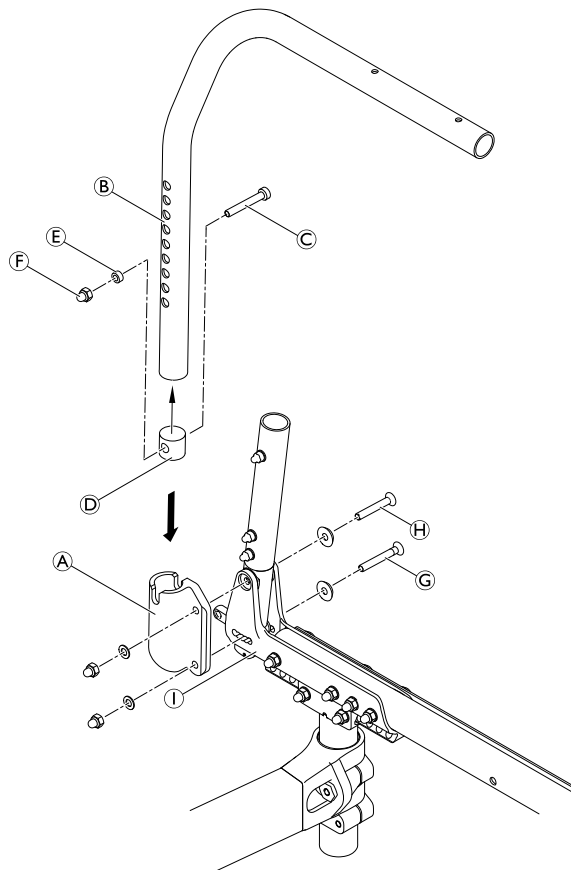

6.7 Castors

6.7.1 Replacing the castor wheel



Allen key (3 mm)



1. Remove the screws **A** and washers **B**.
2. Remove the castor wheel **D** from the castor fork **C**.
3. Place the sleeves **E** in the bearing of the new castor wheel.
4. Place the castor wheel with sleeves in the required position of the fork.
5. Secure the castor wheel to the fork using screws and washers.

A = 4 Nm

Function check:

The wheel may not wobble, but must rotate easily.

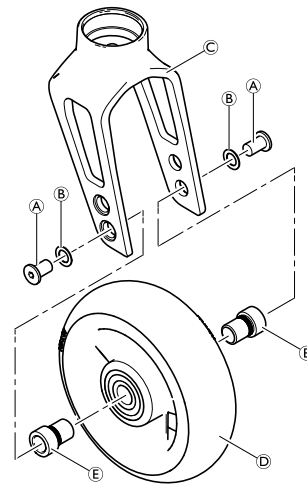

6.7.2 Replacing the castor fork



Allen key (5 mm) / Socket spanner (10 mm)



1. Remove the castor wheel, see 6.7.1 *Replacing the castor wheel*, page 33.
2. Remove bolt **B**, washer **C**, the castor fork **A** with bearings **D** and part **E** from the clevis pin **F**.
3. Replace the castor fork and reinstall in reverse order.

IMPORTANT!

Risk of damaging the castor fork bearing

- Do not overtighten the bolt **B**.
- Tighten the screw only so far that the fork can still be turned freely.

4. Reinstall the castor wheel.



If the clamping part **G** must be replaced, remove bolts, washers and nuts **H** from the castor supporter **I** and reinstall a new clamping part.

H = 10 Nm

Function check

Tip the wheelchair backwards by 90° so that it is lying on the backrest and the rear wheels. Make sure that the clevis pin is as horizontal as possible. Turn the fork upwards (position A) and let it tip downwards. The fork has been correctly adjusted if it easily turns to slightly beyond the bottommost point (position B) and then maximally turns back to the bottommost point (position C). If the fork turns back over the bottommost point or even swings back and forth, it has not been sufficiently tightened. There is a risk that the castor wheel will start to wobble at high speeds.

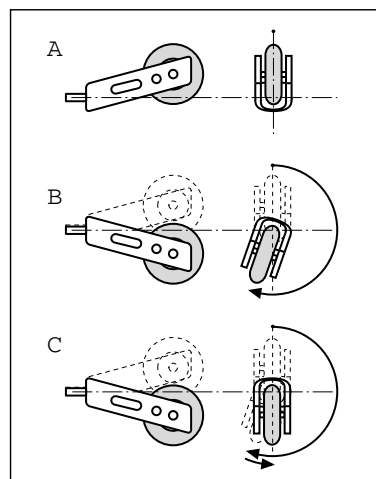
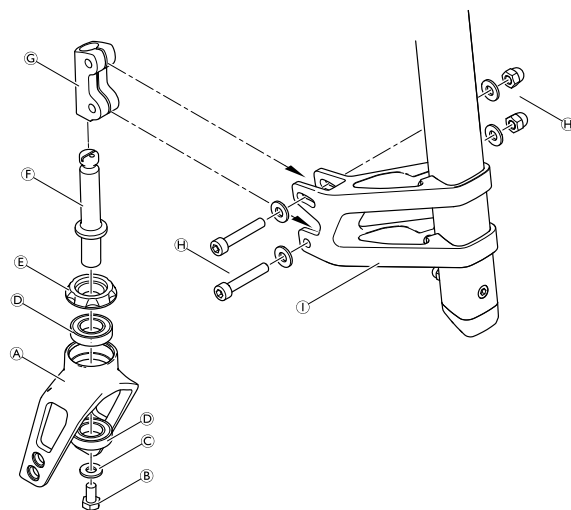

6.7.3 Checking and adjusting the castor angle



Allen key (5 mm) / Wrench (10 mm) / 90° angle (Triangle ruler or similar) / Flat head screwdriver



1. Place the wheelchair on a plane surface.
2. Turn the castor wheel transversely to the rear wheels.
3. Apply a 90° ruler on the castor wheel and check if it is in a 100 % vertical position to the floor.



If there is a gap **A** between the ruler and the castor on the upper or lower rim of the wheel, it clearly indicates that the castor angle is not 90°.

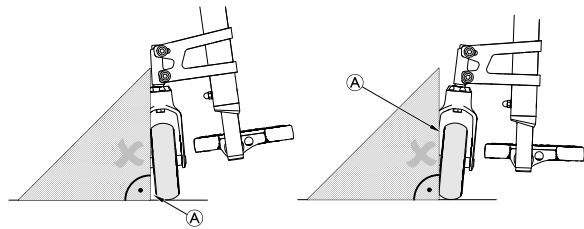

4. If the castor wheel is not vertical, loosen bolts and nuts **B** and **C**.
5. By turning the grub screw **E** reposition the bolt **B** in the groove of the castor supporter until the wheel is 100 % parallel to the vertical side of the ruler.
6. Fine-adjust the castor angle by turning the clevis pin **D** if necessary.
7. Retighten bolts and nuts **B** and **C**.
8. Perform the same adjustment on both sides.

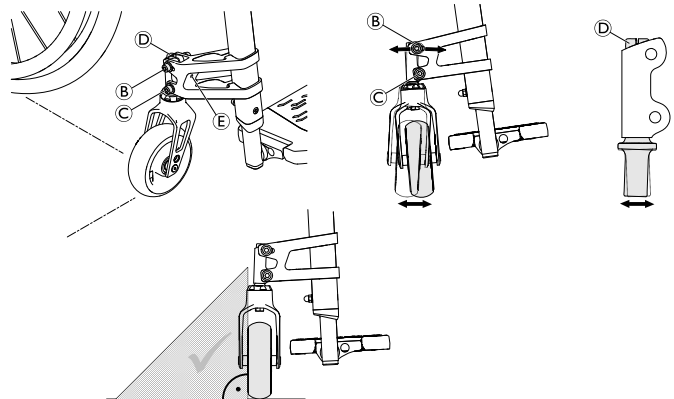

B, **C** = 13 Nm

6.7.4 Checking and adjusting the drift angle



Allen key (5 mm) / Wrench (10 mm) / 90° angle (Triangle ruler or similar)



1. Place the wheelchair on a plane surface.
- 
 The drift angle is measured the same way as the castor angle: For this adjustment the castor wheel has to be turned in driving direction (parallel to the rear wheels).
2. Turn the castor wheel in driving direction, parallel to the rear wheels.
3. Apply a 90° ruler on the castor wheel and check if it is in a 100% vertical position to the floor.
4. If the castor wheel is not vertical, loosen bolts and nuts **B**.
5. Adjust the castor angle by turning the clevis pin **C** until the wheel is 100 % parallel to the vertical side of the ruler.
6. Retighten bolts and nuts **B**.
7. Perform the same adjustment on both sides.

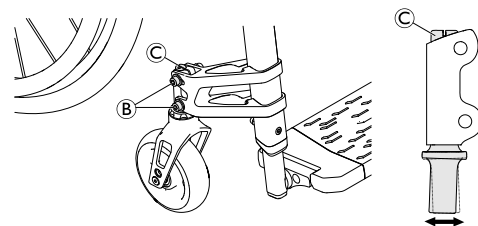
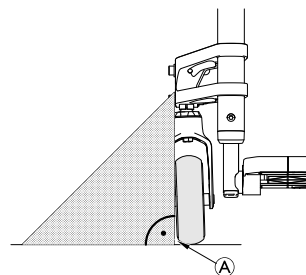

B = 13 Nm

6.7.5 Installing/shifting the castor fork supporter on the frame

The supporter on the frame can be steplessly adjusted.



Allen key (5 mm)



1. Loosen respectively remove bolts ①.
2. Shift the castor fork supporter ② to the required position on the frame tube respectively replace the castor fork supporter with a new one.
3. Retighten bolts with new adhesive.

① = 10 Nm (high-strength)

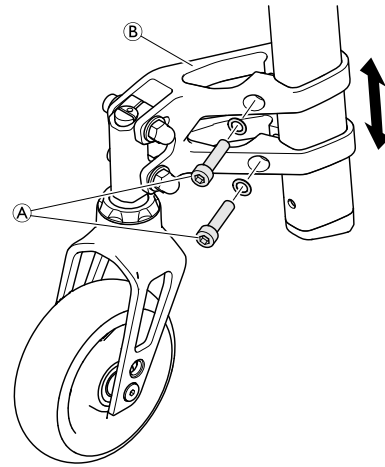

6.8 Rear wheels

6.8.1 Repositioning the rear wheels



The wheelchair is more stable, the further rearwards the rear wheels are positioned.

There are nine possible rear wheel positions, adjustable via the mounting position of the vertical brace.



Allen key (4 mm) / Wrench (10 mm)



1. Remove the bolts ① from slide ② of the vertical brace.
2. Slide the vertical brace on the side support ③ to the desired position.
3. Insert bolts in the new position and tighten the nuts.
4. Carry out the same setting on both sides.

① = 13 Nm

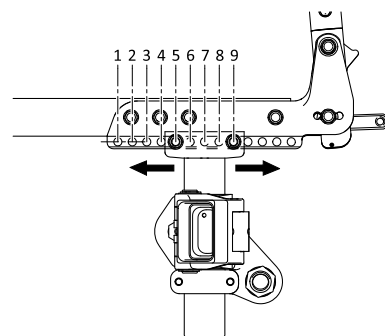
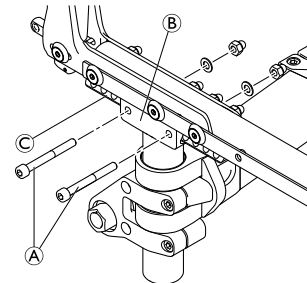

6.8.2 Wheel camber, adapter sleeves

1° adapter sleeves ① or 3° adapter sleeves ② can be used. The wheel camber changes accordingly.

The rear wheels must subsequently be adjusted until parallel.

Adjusting the rear wheel parallelism



Socket spanner (22 mm) / Wrench (19 mm)



1. Measure the distance between the front and rear wheels at axle level.
If this distance is not the same ($x \neq y$):
2. Loosen the adapter sleeve nut ©.
3. Use the open-end spanner to rotate and adjust the adapter sleeves on both sides so that the distance between the front end and rear end of the rear wheels at axle level is identical ($x = y$).
4. Re-tighten the adapter sleeve nut.

© = 35 Nm

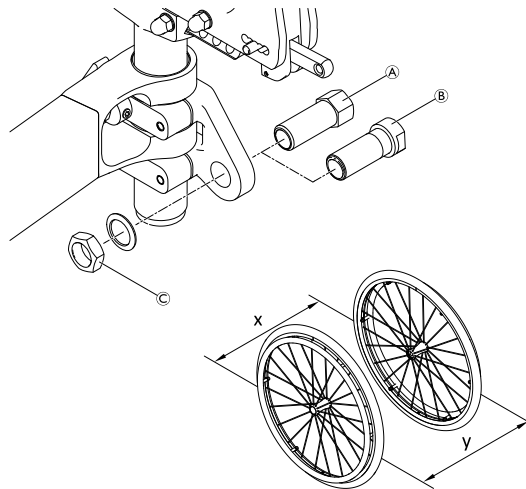

6.8.3 Adjusting the removable axle



Open-end spanner (19) / Straddle spanner (11)



1. Remove the rear wheel.
2. Hold the end of the removable axle ⑥ using the straddle spanner.
3. Adjust the length L of the removable axle by turning the nut ⑤. The length is correctly adjusted if the removable axle engages correctly when installing the wheel and the wheel has just minimal clearance.



The wheels must be exchanged (left to right side and vice versa) after adjusting both removable axles. The adjustment must now be checked or carried out again to ensure the wheels can be switched.

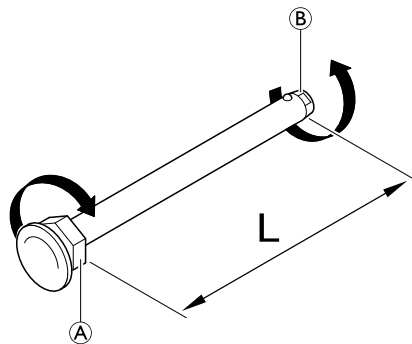

6.8.4 Installing distance sleeves for rear wheels

If new side parts are fitted on a wheelchair (side rests, arm rests, clothes guard or mudguard), the gap between the rear wheels must be increased by attaching additional distance sleeves. Likewise, distance sleeves may also have to be installed if other rear wheels are fitted or if the rear seat height is altered.



Socket spanner (22 mm) / Wrench (19 mm)



1. Remove the rear wheel.
2. Loosen and remove adapter sleeve ⑥, nut and washer ④.
3. Slide the distance sleeve ⑤ onto the thread of the adapter sleeve ⑥.
4. Secure the adapter sleeve to the adapter plate © again using the nut and washer ④.
5. The rear wheels must be subsequently adjusted until parallel, see 6.8.2 *Wheel camber, adapter sleeves*, page 35

© = 35 Nm

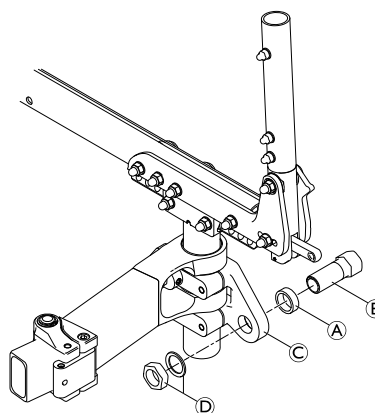

6.8.5 Adapter plate — Adjusting the folding unit / Installing the adapter plate





Allen key (5 mm)

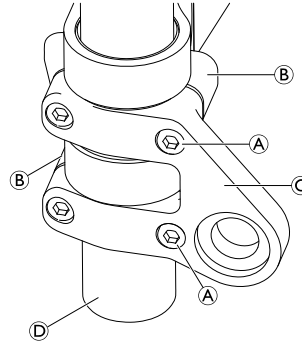

1. Slightly loosen the two bolts (A).
2. If an option is mounted loosen the nuts of the adaption holder, see 6.10 Options and Accessories, page 39.
3. Move the adapter plate (C) with both brackets (B) on the vertical tube D into the desired position.
4. Fasten the adapter plate with the two bolts (A).

(A) = 13 Nm



 Parking brakes and mudguard must be repositioned if the position of the rear wheel is changed.

6.8.6 Repairing or changing an inner tube



Tyre lever



1. Remove the rear wheel and release any air from the inner tube.
2. Lift one tyre wall away from the rim using a bicycle tyre lever. Do not use sharp objects such as a screwdriver which could damage the inner tube.
3. Pull the inner tube out of the tyre.
4. Repair the inner tube using a bicycle repair kit or, if necessary, replace the tube.
5. Inflate the tube slightly until it becomes round.
6. Insert the valve into the valve hole on the rim and place the tube inside the tyre (the tube must lie right round the tyre with no creases).
7. Starting close to the valve, push the tyre wall over the edge of the rim using both hands. When doing this, check all the way round to ensure that the inner tube is not trapped between the tyre and the rim.
8. Inflate the tube to its maximum operating pressure. Check that no air is escaping from the tyre.

6.8.7 Replacing a solid tire

Removing a solid tire



Lever bar



1. Push on the side wall of the tire while inserting a lever bar.

 Some solid tires are quite a bit smaller than the rim so this can be difficult.

2. Once one lever is in, insert a second lever and push the tire over the rim until it comes off.

 If you are unable to push off the tire, it needs to be cut off. Make sure not to damage the rim.

Installing a solid tire

Installing solid tires on a rim can only be accomplished with the right tools. Most of these tires are smaller than the rim they fit and need to be stretched to be installed. Follow the instructions that come with the tools for the process.

6.8.8 Replacing rear wheel spokes

We recommend having the spokes replaced by a qualified technician.

6.9 Parking brakes

6.9.1 Installing the parking brake



Allen key (5 mm)



1. Position the brake holder ② around the front frame tube ③.
2. Place the brake ④ in the brake holder.
3. Screw the bolt ① with washer into the brake assembly but do not tighten.
4. Rotate the brake holder assembly around the frame tube to adjust the lateral distance of the brake.
5. Rotate the brake in the brake holder to achieve a horizontal position of the brake rod ⑤ to the tyre.
6. Fully apply the brake and slide it towards the tyre until the brake rod bears flush against the tire.
7. Release the brake and slide it 3 mm backwards and tighten the bolt.

① = 13 Nm

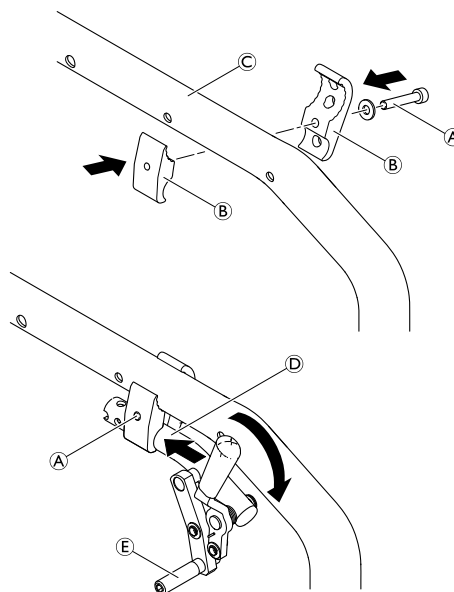

6.9.2 Adjusting the parking brake



Allen key (5 mm)



WARNING!
Risk of injury

- The parking brakes must be readjusted whenever the rear wheels are replaced or the wheel camber is changed.
- The parking brake function is only guaranteed if the tyre has the corresponding inflation pressure.

1. Check the tyre pressure in the rear wheels and correct if necessary.
2. Slightly loosen bolt ① of the brake holder.
3. Change the position of the brake assembly as described in chapter 6.9.1 *Installing the parking brake, page 38*.
4. Tighten the bolt ①.

IMPORTANT!

- The force to apply the parking brake must be 60 N (maximum).



Very little force is required for activating and deactivating the brake. If necessary, a brake lever extension can be mounted.

Visual check

Check that the parking brakes are positioned correctly. The brake is set correctly if the brake rod depresses the tire by no more than 4 mm when the brake is applied. (In the case of push/pull and standard brakes this will be the case when the brake shoe is approx. 25 mm away from the tire when released.)

Function check

Place a weighted wheelchair with parking brake engaged facing uphill and then facing downhill on a ramp with an incline of 7°. The wheelchair must not move.

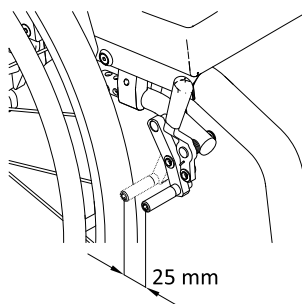

6.10 Options and Accessories

6.10.1 Installing the antitipper



Allen key (3, 5, 6 mm) / Socket spanner (22) / Wrench (19)



1. Remove adapter sleeve ③, nut ④ and washer ⑤.
2. Mount the antitipper ① with the adapter sleeve ③, nut ④ and washer ⑤, sleeve ①, and the screw ② to the clamping part ⑥.
3. Adjust the angle of the antitipper and tighten in the desired position with adjusting screws ①.
4. Adjust the rear wheel parallelism, *6.8.2 Wheel camber, adapter sleeves, page 35.*

④ = 35 Nm

② = 13 Nm

① = 4 Nm

Adjusting the length

1. Press the spring pin ⑫. Slide the inner part of the antitipper ⑬ to the required position until the spring pin locates in the correct hole.



Optionally, antitippers can be mounted with pre-attached transit wheels ⑭ (shown in graphic).

Transit wheels require a pre-drilled antitipper tube. Antitipper tubes with pre-attached transit wheels can be ordered from Invacare.

WARNING!

Risk of tilting

– When choosing antitippers with transit wheels, make sure to have them installed on both sides of the wheelchair.



To remove the antitipper press button ⑨ and slide it downwards out of the holder.

Function control:

The distance between the antitipper and the ground must be 50 - 70 mm. It must be easy to fold up the antitipper. Tip the wheelchair backwards using the antitipper until the axle is perpendicular to the antitipper's point of contact with the ground. In this position, the distance between the rear wheel and the ground must be $x \geq 50$ mm.

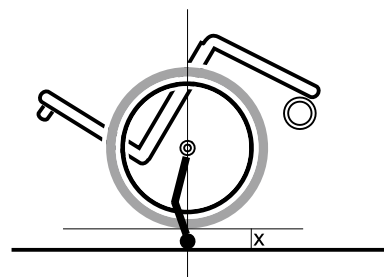
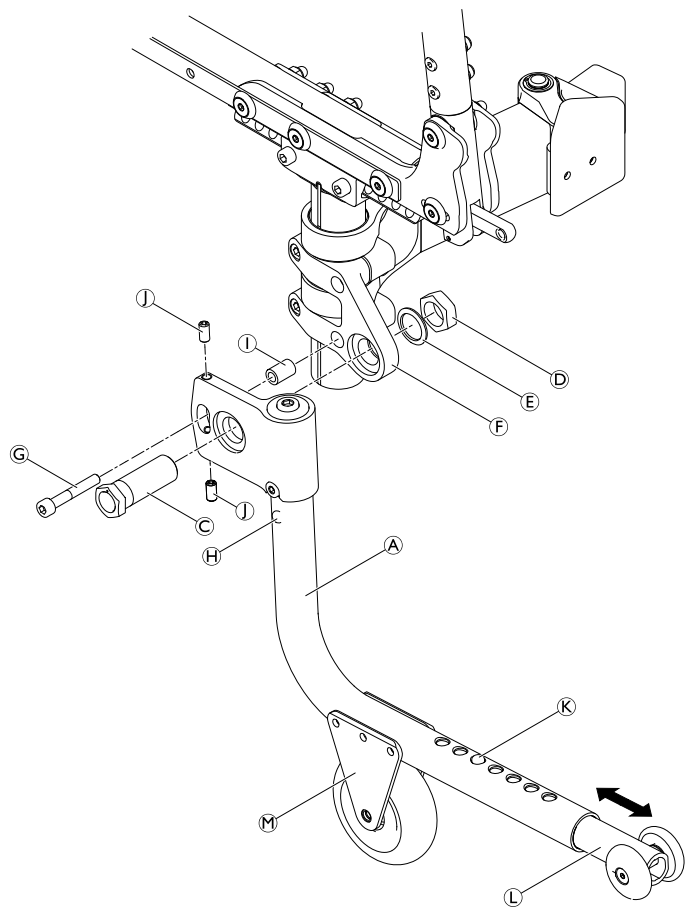

6.10.2 Installing the tipper aid and/or cane holder

These instructions apply to the following options:

- Tipper aid with cane holder
- Cane holder
- Tipper aid



Socket spanner (10)



1. Attach the adaption holder (A) onto the bracket (B) using the two nuts and washers (C).
2. Slide the tipper aid tube (D) into the adaption holder and fasten it with the spring clip (E).
For cane holder option:
3. Remove the screw (F) from the backrest cover then replace it together with the strap (G).

Ⓒ = 13 Nm



The cane holder can also be repositioned on the tube.

Function control:

The tipper aid / cane holder may not touch the floor if the wheelchair is tipped backwards.

1. If the tipper aid / cane holder touches the floor remove it and change the position of the spring clip (E). This is done by removing the tube end cap then pushing the spring clip one hole further into the tube using a screwdriver.

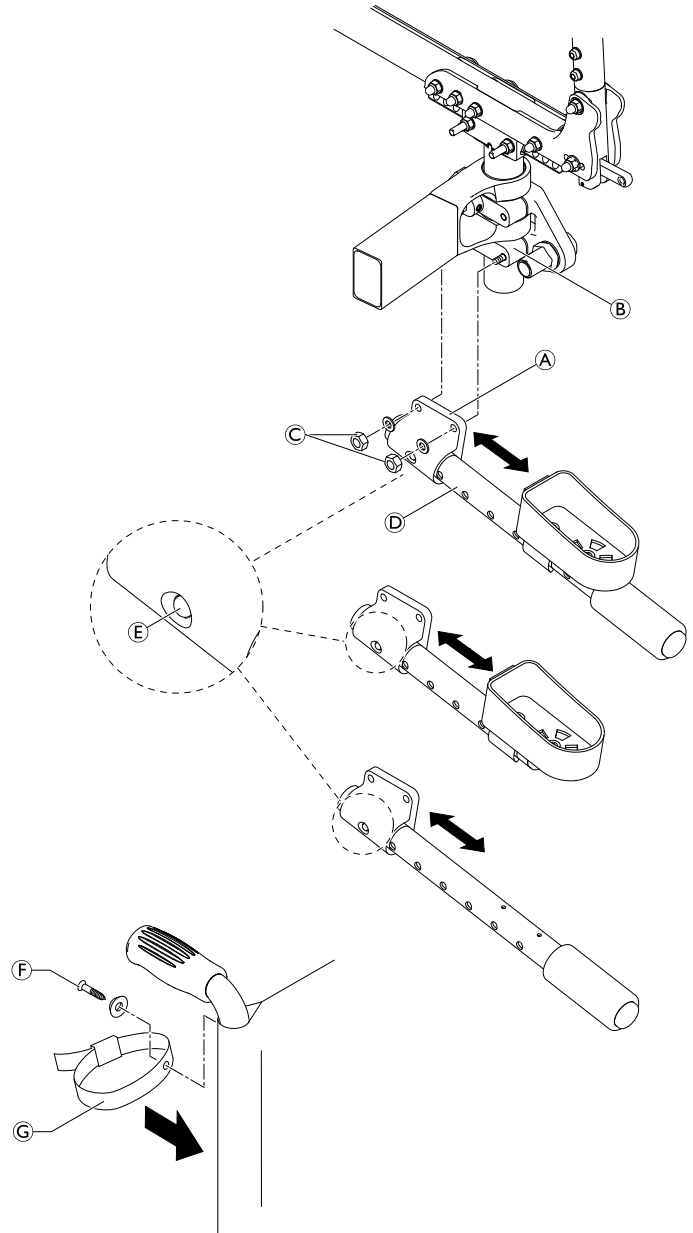

6.10.3 Installing the posture belt



Allen key (5 mm) / Socket spanner (10) / Plastic hammer



1. Install the steel strap **A** with the bolt **C** on both sides of the side profile **B**, pressing the upper part of the steel strap inwards, e.g. using a plastic hammer.

C = 13 Nm

WARNING!

Risk of injury due to incorrect installation

– Make sure that the webbing of the posture belt is not twisted during assembly and the locking mechanism shows towards the front.

WARNING!

Risk of injury due to incorrect installation

– Make sure that the seat cover does not get caught between the steel strap and the side supporters during assembly.

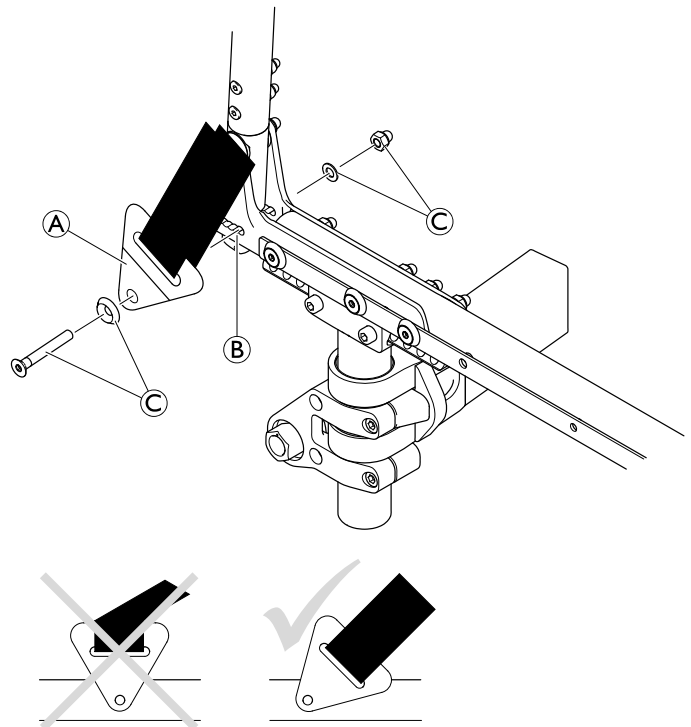

6.10.4 Installing the positioning belt



Allen key (3 mm)



1. Remove the two bolts **A** and washers **B**.
2. Position the adapter plate **C** against the seat, aligning the hole with the first frame hole, and the groove with second frame hole.

If necessary, reposition the clamping part of the parking brake.

WARNING!

Risk of injury due to incorrect installation

– Make sure that the parking brakes are positioned correctly to ensure the function.

3. Insert bolts with washers and tighten.
4. Mount the belt **D** to the adapter plate **C** in the required hole using bolt **E** and nut **F**.

The washer **G** can be placed between the belt and the nut to avoid the rotation of the belt.

If necessary, reduce the length of the belt by cutting straight across the belt at position **H**. Trim along the curved line **I** for a proper appearance.

A = 5 Nm

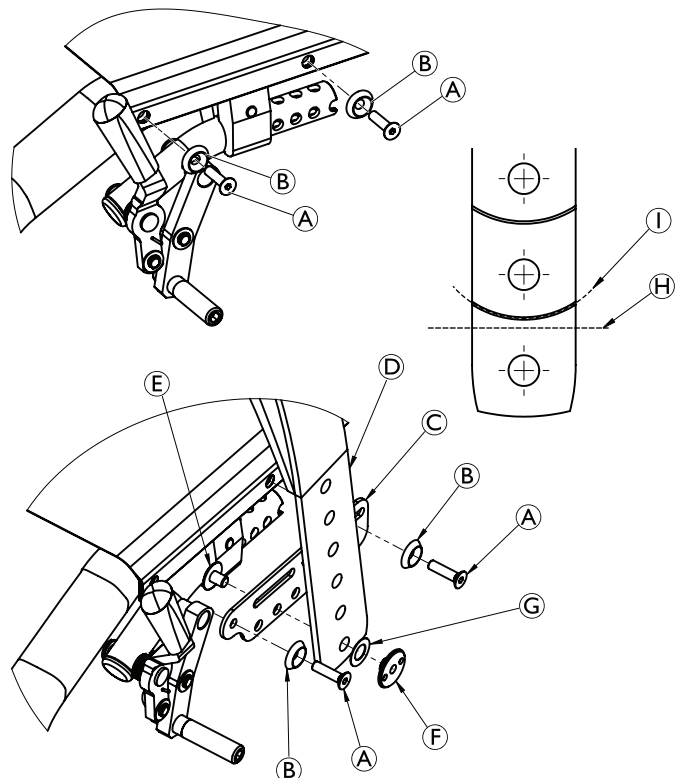

Invacare distributors

Asia:

Invacare Asia Ltd.
1 Lenton Place, North Rocks NSW 2151
Australia
Phone: (61) (02) 8839 5333
Fax: (61) (02) 8839 5343
asiasales@invacare.com
www.invacare.com

Deutschland:

Invacare GmbH,
Alemannenstraße 10
D-88316 Isny
Tel: (49) (0)7562 700 0
Fax: (49) (0)7562 700 66
kontakt@invacare.com
www.invacare.de

Ireland:

Invacare Ireland Ltd,
Unit 5 Seatown Business Campus
Seatown Road, Swords, County Dublin
Tel : (353) 1 810 7084
Fax: (353) 1 810 7085
ireland@invacare.com
www.invacare.ie

Norge:

Invacare AS
Grensesvingen 9, Postboks 6230,
Etterstad
N-0603 Oslo
Tel: (47) (0)22 57 95 00
Fax: (47) (0)22 57 95 01
norway@invacare.com
www.invacare.no

Sverige:

Invacare AB
Fagerstagatan 9
S-163 53 Spånga
Tel: (46) (0)8 761 70 90
Fax: (46) (0)8 761 81 08
sweden@invacare.com
www.invacare.se

Australia:

Invacare Australia Pty. Ltd.
1 Lenton Place, North Rocks NSW 2151
Australia
Phone: 1800 460 460
Fax: 1800 814 367
orders@invacare.com.au
www.invacare.com.au

Eastern Europe, Middle East & CIS:

Invacare EU Export
Kleiststraße 49
D-32457 Porta Westfalica / Germany
Tel: (49) (0)57 31 754 540
Fax: (49) (0)57 31 754 541
webinfo-eu-export@invacare.com
www.invacare-eu-export.com

Italia:

Invacare Mecc San s.r.l.,
Via dei Pini 62,
I-36016 Thiene (VI)
Tel: (39) 0445 38 00 59
Fax: (39) 0445 38 00 34
italia@invacare.com
www.invacare.it

Österreich:

Invacare Austria GmbH
Herzog-Odilo-Straße 101
A-5310 Mondsee-Tiefgraben
Tel: (43) 6232 5535 0
Fax: (43) 6232 5535 4
info-austria@invacare.com
www.invacare.at

Schweiz / Suisse / Svizzera:

Invacare AG
Benkenstrasse 260
CH-4108 Witterswil
Tel: (41) (0)61 487 70 80
Fax: (41) (0)61 487 70 81
switzerland@invacare.com
www.invacare.ch

Belgium & Luxemburg:

Invacare nv
Autobaan 22
B-8210 Loppem
Tel: (32) (0)50 83 10 10
Fax: (32) (0)50 83 10 11
belgium@invacare.com
www.invacare.be

España:

Invacare SA
c/Areny s/n, Polígono Industrial de Celrà
E-17460 Celrà (Girona)
Tel: (34) (0)972 49 32 00
Fax: (34) (0)972 49 32 20
contactsp@invacare.com
www.invacare.es

Nederland:

Invacare BV
Galvanistraat 14-3
NL-6716 AE Ede
Tel: (31) (0)318 695 757
Fax: (31) (0)318 695 758
nederland@invacare.com
www.invacare.nl

Portugal:

Invacare Lda
Rua Estrada Velha, 949
P-4465-784 Leça do Balio
Tel: (351) (0)225 1059 46/47
Fax: (351) (0)225 1057 39
portugal@invacare.com
www.invacare.pt

United Kingdom:

Invacare Limited
Pencoed Technology Park, Pencoed
Bridgend CF35 5AQ
Tel: (44) (0) 1656 776 222
Fax: (44) (0) 1656 776 220
uk@invacare.com
www.invacare.co.uk

Danmark:

Invacare A/S
Sdr. Ringvej 37
DK-2605 Brøndby
Tel: (45) (0)36 90 00 00
Fax: (45) (0)36 90 00 01
denmark@invacare.com
www.invacare.dk

France:

Invacare Poirier SAS
Route de St Roch
F-37230 Fondettes
Tel: (33) (0)2 47 62 64 66
Fax: (33) (0)2 47 42 12 24
contactfr@invacare.com
www.invacare.fr

New Zealand:

Invacare New Zealand Ltd
4 Westfield Place, Mt Wellington 1060
New Zealand
Phone: 0800 468 222
Fax: 0800 807 788
sales@invacare.co.nz
www.invacare.co.nz

Suomi:

Camp Mobility
Patamäenkatu 5, 33900 Tampere
Puhelin 09-35076310
info@campmobility.fi
www.campmobility.fi



Invacare France Operations SAS
Route de St Roch
F-37230 Fondettes
France

1659360-B 2019-07-02



Making Life's Experiences Possible®

Küschall
UNLIMIT YOUR WORLD